

MAIN CATALOG

# PLC Automation

PLCs, Control Panels, Engineering Suite  
AC500, CP600, ABB Ability™ Automation Builder





# PLC Automation

## PLCs, Control Panels, Engineering Suite

**002–055**      **PLC Automation product family**

**056–069**      **ABB Ability™ Automation  
Builder  
Integrated engineering suite**

**070–099**      **AC500-eCo  
Entry level PLC solutions**

**100–149**      **AC500  
High performance modular PLC**

**150–195**      **AC500-XC  
PLC operating in eXtreme  
Conditions**

**196–209**      **AC500-S  
Functional safety PLC**

**210–219**      **CP600-eCo, CP600 and  
CP600-Pro Control panels**

**220–279**      **Application descriptions and  
additional information**

**280–286**      **Index**





---

# PLC Automation product family

<b>004–007</b>	<b>Overview</b>
<b>008–009</b>	<b>Connectivity</b>
<b>010–013</b>	<b>ABB Ability™ Automation Builder</b>
<b>014–015</b>	<b>AC500 libraries and software</b>
<b>016–019</b>	<b>PLCs at a glance...</b>
<b>020–021</b>	<b>AC500 CPU Selector</b>
<b>022–023</b>	<b>AC500 V3 CPU Selector</b>
<b>024</b>	<b>AC500-eCo – modular concept</b>
<b>025</b>	<b>AC500 and AC500-XC – modular concept</b>
<b>026–027</b>	<b>AC500-eCo system characteristics</b>
<b>028–029</b>	<b>AC500-eCo V3 system characteristics</b>
<b>030–031</b>	<b>AC500-eCo V3 overview</b>
<b>032–033</b>	<b>AC500 system characteristics</b>
<b>034–035</b>	<b>AC500 PM595 controller system characteristics</b>
<b>036–037</b>	<b>Condition monitoring system CMS based on AC500</b>
<b>038–039</b>	<b>AC500 V3 enhanced connectivity and performance</b>
<b>040–041</b>	<b>AC500 extreme conditions</b>
<b>042–043</b>	<b>AC500-S safety PLC – functional safety</b>
<b>044</b>	<b>Visualization options</b>
<b>045</b>	<b>PB610 Panel Builder 600</b>
<b>046 –047</b>	<b>CP600 control panels platform at a glance ...</b>
<b>048–049</b>	<b>CP600-eCo control panels</b>
<b>050–051</b>	<b>CP600 control panels</b>
<b>052–053</b>	<b>CP600-Pro control panels</b>
<b>054–055</b>	<b>PLC Automation website – online tools</b>

# PLC Automation product family

## Overview

ABB offers a comprehensive range of scalable PLCs and robust HMI control panels. Since its launch, the AC500 PLC platform has achieved significant industry recognition for delivering high performance, quality and reliability.

### Comprehensive range

- ABB delivers scalable, flexible and efficient ranges of automation components to fulfill all conceivable requirements of the most diverse automation applications.
- ABB's automation devices deliver solutions with high performance and flexibility to be effectively deployed within various industries and applications including water, building infrastructure, data centers, renewable energy, machinery automation, material handling, marine and many more.

### Engineering suite

- ABB Ability™ Automation Builder is the integrated software suite for machine builders and system integrators requiring state-of-the-art productive machine and system automation.
- Combining the tools required for configuring, programming, debugging and maintaining automation projects from one common intuitive interface, Automation Builder addresses the largest single cost element of most of today's industrial automation projects - software.

### Programmable Logic Controllers PLCs

- The AC500-eCo, AC500, AC500-XC and AC500-S scalable PLC ranges provide solutions for small, medium and high-end applications.
- Our AC500 PLC platform offers different performance levels and is the ideal choice for high availability, extreme environments, condition monitoring, motion control or safety solutions.
- Our AC500 PLC platform offers interoperability and compatibility in hardware and software from compact PLCs up to high end and safety PLCs.

### Control panels

- CP600-eCo, CP600 and CP600-Pro control panels in combination with the PB610 Panel Builder 600 offer a wide range of features and functionalities for maximum operability.
- ABB control panels are distinguished by their robustness and easy usability, providing all the relevant information from production plants and machines at one single touch.

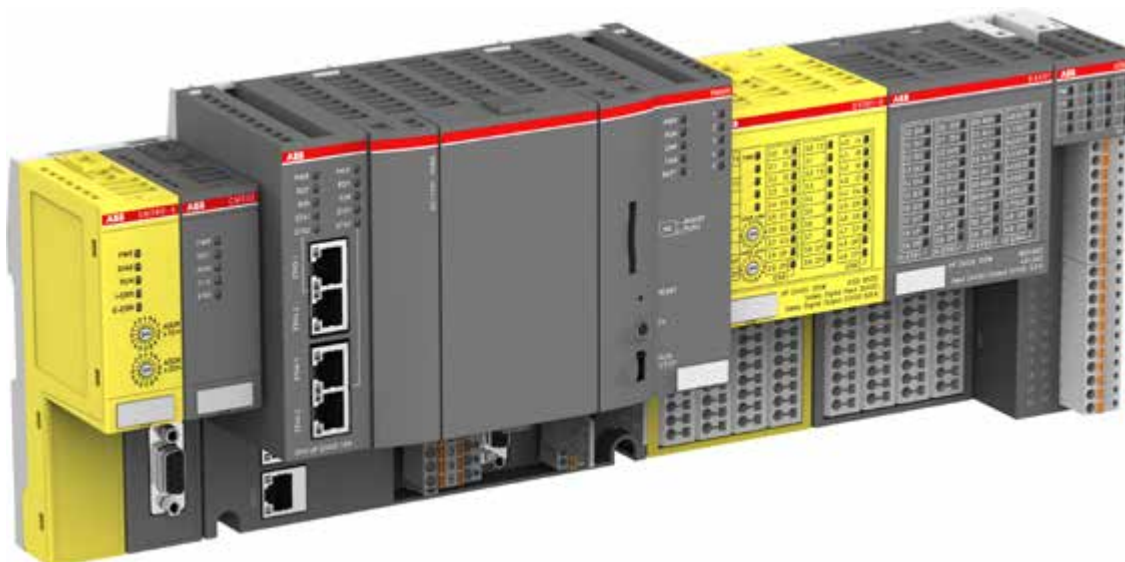

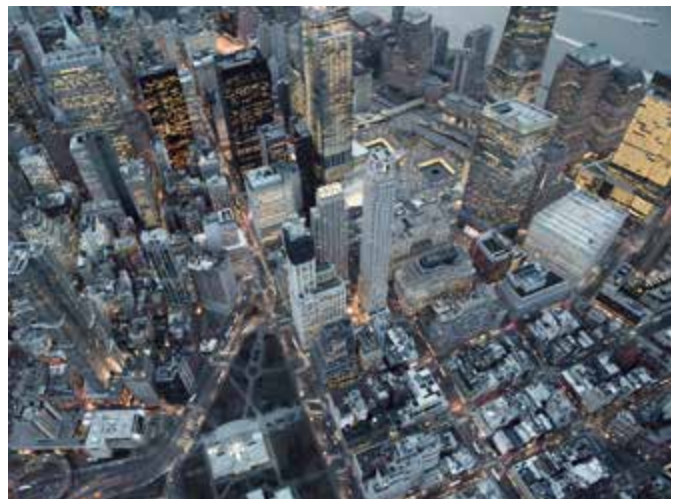



# PLC Automation product family

## Overview

### Engineering suite



#### ABB Ability™ Automation Builder

- Connects the engineering tools for PLC, safety, control panels, drives and motion.
- Combines the tools required for configuring, programming, debugging and maintaining automation projects from one common intuitive interface.



#### Library packages

- For efficient engineering of demanding applications.
- Easy-to-use application examples.

### Visualization



#### CP600-eCo

- Economical control panel aimed for standard functions and high usability for clear interaction with the operation process.

### Programmable Logic Controllers PLCs



#### AC500-eCo

- Compact PLC for economical automation solutions in smaller applications.
- Integrates seamlessly into the broader AC500 PLC platform.

### I/O modules



#### S500-eCo

- Range of modular I/Os for economical configurations in smaller applications.
- Connected directly to the AC500 or AC500-eCo CPU modules.
- S500-eCo I/O modules can be mixed with standard S500 modules.
- Usage as remote I/O with fieldbus communication interface modules.



**CP600**

- Robust HMI with high visualization performance, versatile communication and representative design for machines and systems.



**CP600-Pro**

- HMI with high end visualization performance, multi-touch operation, versatile communication and representative design, partly usable to trigger safety actions with AC500-S.



**AC500**

- Powerful PLC featuring a wide range of performance, communications and I/O capabilities for industrial applications.
- For complex, high-speed machinery and networking solutions.



**AC500-XC**

- Extreme condition PLC variant.
- With extended operating temperature, immunity to vibration and hazardous gases, use at high altitudes and in humid environments.



**AC500-S**

- Integrated safety PLC (SIL3, PL e) for safety applications in factory, machinery or process automation area.
- For simple and complex safety solutions.



**S500**

- Range of modular I/O with protected outputs and comprehensive diagnosis, covering a wide range of signal types.
- Installed as remote I/O with a communication interface module or directly connected to the AC500 CPU.
- Support of different fieldbuses to use the S500 I/O modules with PLCs from different manufacturers.



**S500-XC**

- Extreme condition S500 I/O variant.
- With extended operating temperature, immunity to vibration and hazardous gases, use at high altitudes and in humid environments.



**S500-S**

- Safety S500 I/O variant.
- Extreme condition variants available.



# PLC Automation product family

## Connectivity

ABB's PLC and control panel portfolio provides a high number of scalable products, communication protocols and connectivity options, from the field layer right through to the management and visualization layers.

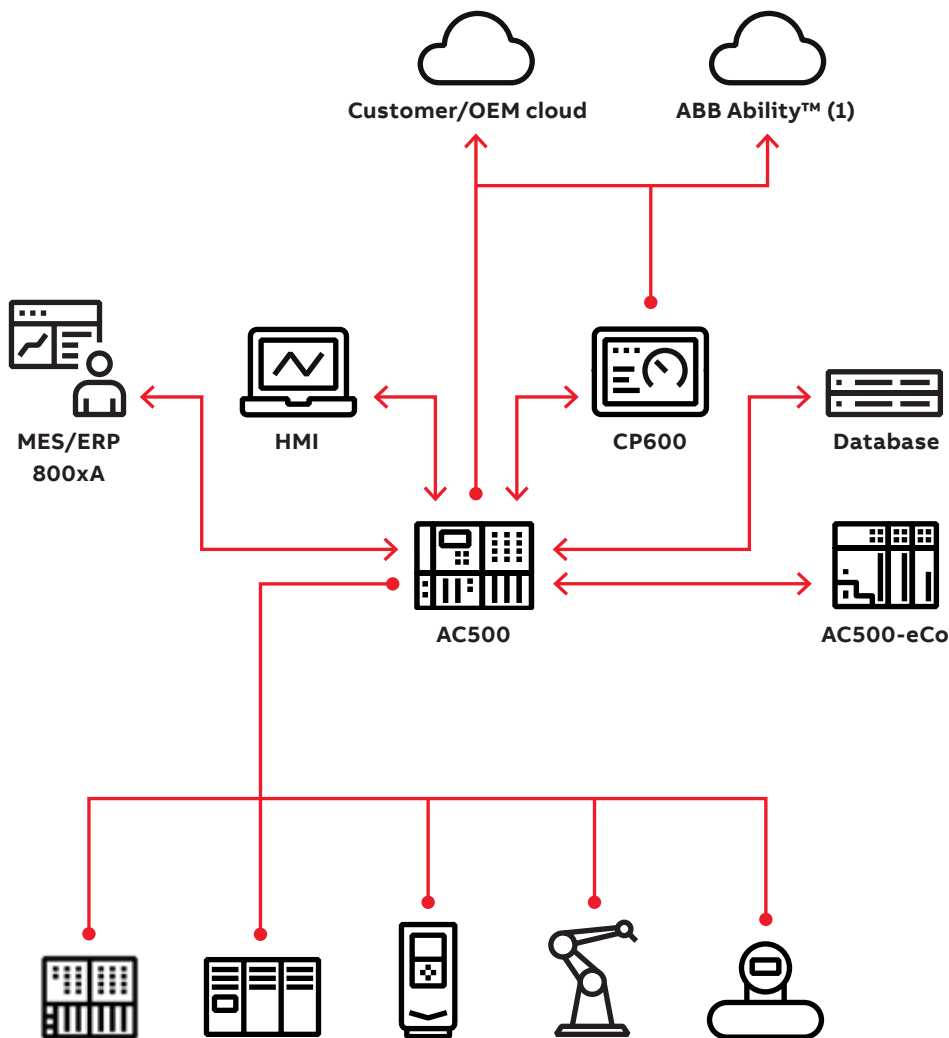

(1) In preparation

### IT network/Internet

- FTP(S)
- HTTP(S)
- MQTT
- OPC UA
- SNTP

### Factory/site network

- BACnet
- FTP(S)
- HTTP(S)
- IEC 60870-5-104
- IEC 61850
- KNX
- MySQL/MSSQL
- OPC DA/AE
- OPC UA
- SNMP
- SNTP
- TCP/IP
- UDP

### Control network

- CANopen
- CAN 2A/2B
- EtherCAT
- Ethernet/IP (1)
- IEC 60870-5-104
- IEC 61850
- Modbus RTU
- Modbus TCP
- PROFIBUS DP
- PROFINET/PROFIsafe
- SAE J1939



Protocol	Application
Connector to SQL Database	Save to or get data from MSSQL or MySQL databases
FTP(S)	Server and client for secure and efficient exchange of big data
HTTP Request	Request information like temperature, humidity etc. from devices with web server functionality
HTTP(S)	Publish HTML5 websites for monitoring and control
IEC 60870-5-104	Telecontrol in distributed plants such as water, solar, power infrastructure (control- and substation)
IEC 61850	Mainly used in the electrification part of infrastructure projects
KNX/BACnet	Standard protocols used in building and infrastructure automation projects
MQTT	Certificated based publishing of data to private clouds for dashboards or data analytics
OPC DA/AE/UA	Connectivity for SCADA, DCS and management applications
SNTP/SNMP	Protocol for time synchronization, network supervision and configuration
UDP and TCP/IP	Implement specific and efficient own communication

# PLC Automation product family

## ABB Ability™ Automation Builder

Engineering productivity for machine builders and system integrators.



### Product license options

	Automation Builder Basic	Automation Builder Standard	Automation Builder Premium
Free	●		
AC500-eCo	●	●	●
AC500 with local I/O & network (1)	●	●	●
AC500 with fieldbus (2)		●	●
AC500-S Safety		○	○
Drive Manager		●	●
Drive application programming (3)	●	●	●
Motion programming	● (4)	●	●
Panel Builder 600	○	●	●
Panel Builder 600 Basic	●	●	●
Integrated engineering (5)		●	●
Productivity features (6)			●
Additional features (7)		○	○

- fully
- partly

(1) TCP protocols, Modbus, IEC 60870-5-104, CS31

(2) PROFIBUS, PROFINET, EtherCAT, CAN

(3) Drive application programming for drives with embedded PLC (only available with Automation Builder 2.1 and before). Drive Composer pro license included in Standard and Premium Edition.

(4) No fieldbus connectivity in Automation Builder Basic

(5) PLC, Safety, Panel, Drive, Motion, SCADA

(6) C/C++, ECAD data exchange, CSV interface extensions, project compare, project scripting

(7) Virtual Commissioning Platform for virtual system testing, Professional Developer Tools e.g. for multi-user engineering or static code analysis



**Discover engineering productivity when designing your automation solutions**

Automation Builder is ABB's integrated programming, simulation, commissioning and maintenance environment for PLCs, safety, drives, motion, control panels and SCADA. Automation Builder combines the proven ABB tools Drive Manager, Drive composer pro, Mint WorkBench, Panel Builder and ABB zenon.

**Always get the right scope of Automation Builder for your automation solutions**

One single software installer helps you to create and maintain your personal Automation Builder configuration - either on your PC or on a server. Any changes or updates are just a matter of a few mouse clicks.

The Automation Builder licensing system is designed for supporting most operation scenarios. Licenses can be installed on PCs, USB dongles or license servers. In case of changes in the organization or in the engineering workflows the licenses can easily be transferred to where you need them.

**Next level engineering efficiency**

Improve your engineering efficiency by maximizing data re-use. Data that is available from third party tools can be imported or synchronized, either via dedicated interfaces or generic Excel sheets. Configurations that have been created for the PLC can automatically be re-used e.g. for the configuration of drives or operator panels.

Engineering efforts can be reduced further by using easy-to-use libraries e.g. for wind, water, solar, drives, motion, robotics, safety and building automation applications. And in case building blocks are missing for your automation solution simply create them yourself. Project scripting allows you to automate the creation of any part of your configuration or application.

The quality of the resulting PLC application can be automatically checked by static code analysis. More than 100 pre-defined rules can be used to define and keep the quality level that is required for your business.

# PLC Automation product family

## ABB Ability™ Automation Builder

### **Fast track to comprehensive applications**

For creating the application code all five IEC 61131-3 languages can be used. This opens up access to a large community of developers sharing proven code snippets. Even existing PC based functions or protocols can be re-used by using the C/C++ integration. Furthermore, Simulink models and MATLAB functions can be used as well by converting them to PLC code.

### **Minimized efforts for project code and data administration**

Configure and program all devices of your automation solution in one single project. This makes it easy to share your solutions with others. For more advanced usage the integrated version control system supports further scenarios like multi-user engineering or product line management.

Managing the life-cycle of your automation solutions is also easy. The annual Automation Builder release also supplies you with the latest versions of device firmware. The decision, whether to use the latest firmware with the latest feature set or to keep the current firmware with the current feature set can be made for each project and independent of the installed Automation Builder version.

### **Speeding up during commissioning and maintenance**

Whenever there is an issue in the automation system, it is required to quickly and efficiently fix it. Automation Builder supports this by a generic three-step approach:

- General diagnosis provides a traffic light view on devices and (sub)systems.
- Detailed diagnosis provides detailed information e.g. about the source and the type of the issue.
- Extended diagnosis is available for some subsystems such as fieldbuses and offers advanced commissioning functions such as comparing connected vs. configured devices or manual control of bus states.

The diagnosis information is accessible not only via Automation Builder, but also via the AC500 display, the PLC application or operator panels.

### **Easily create a connected world**

Connectivity can be achieved in multiple ways. Different cloud protocols like MQTT or OPC UA are deeply integrated into ABB AC500 PLCs. For advanced connectivity needs the integration with CP600 operator panels or even with the ABB zenon software can be used for further processing and transmission of any data. Setting up the interfaces and sharing the data is not much more than a single click in Automation Builder.

### **Advanced simulation – a game changer in engineering**

Simulate all kinds of applications with minimum effort. Test the complete system seamlessly before involving real hardware. Even complex systems can be built up efficiently, ensuring smooth interaction of all components and operator training at an early stage.



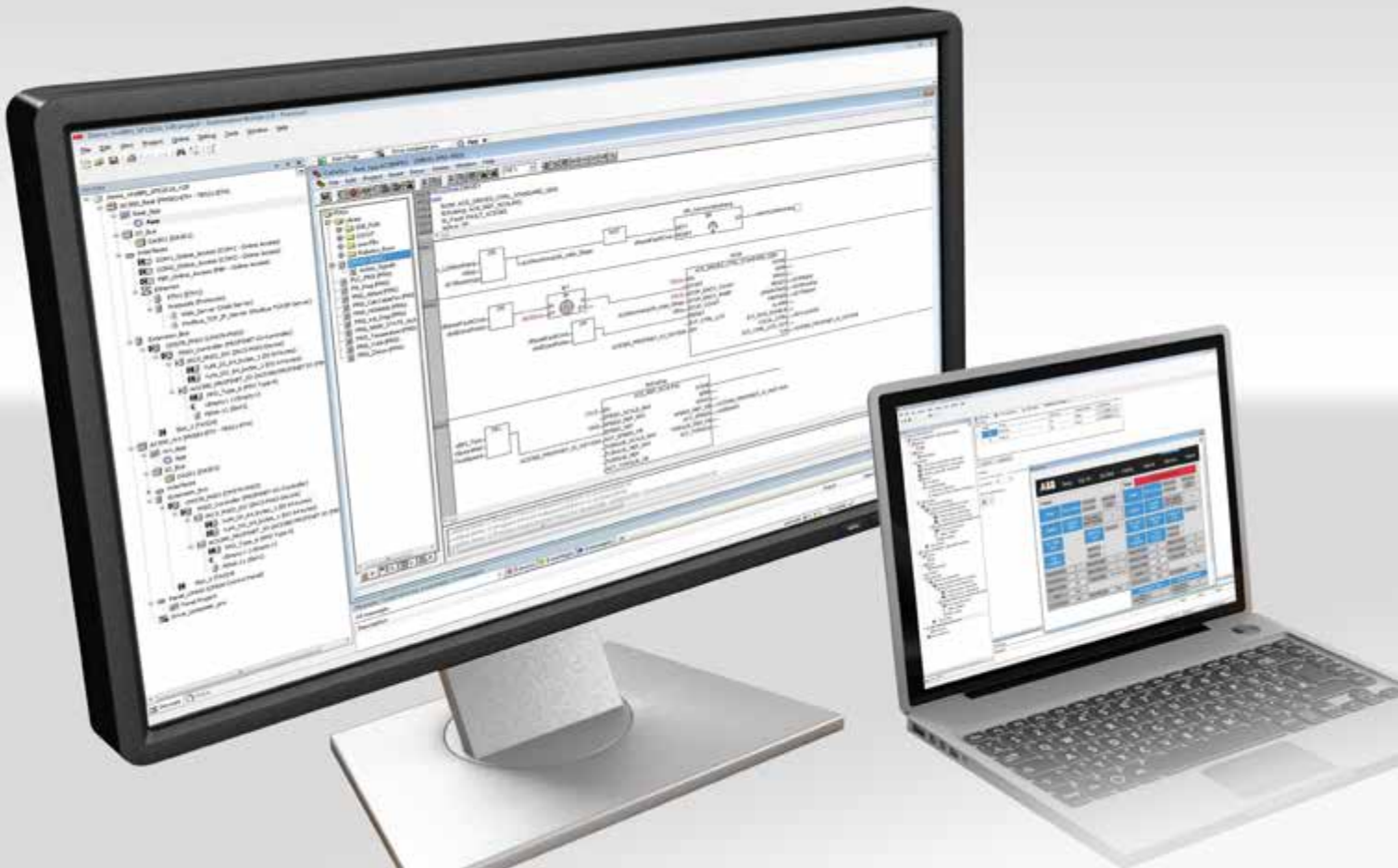

---

### Download Automation Builder from

[www.abb.com/automationbuilder](http://www.abb.com/automationbuilder)

Familiarize yourself with Automation Builder using the 30-day test license.

# PLC Automation product family

## AC500 libraries and software

A good investment for system integrators and end-users, AC500 libraries and software improve stability while reducing warranty costs and service. Library and software packages contain functions or protocols and easy-to-use examples for minimal programming effort and quick implementation of complex and demanding applications.

AC500 libraries and software deliver the seamless integration of PLCs, drives and HMI required to build and commission automation solutions quickly and easily. AC500 libraries and software by ABB are maintained to ensure that your programs can also be used with less risk.





#### **Solar library**

Library package for solar trackers increasing energy efficiency, providing quick commissioning and excellent positioning accuracy.

#### **Water library**

Library package with energy efficiency functionalities offering quick commissioning of water applications, such as pump stations with remote communication.

#### **Temperature control library**

Library package for the advanced PID temperature control of demanding applications, for example extrusion.

#### **HA-CS31 library**

Library package adds high availability system functionality for redundant hot standby over serial CS-31 bus.

#### **Drive integration library**

Library package for the quick integration of ABB ACS drives using different fieldbusses.

#### **Motion control library**

Library package for decentral, central and coordinated motion according to the PLCopen standard.

#### **BACnet library**

Library package adds BACnet-ASC device profile for communication to BMS Building Management Systems in larger infrastructure projects.

#### **HA-Modbus TCP library**

Library package adds High Availability System functionality for redundant hot standby over Ethernet field network via Modbus TCP.

#### **KNX protocol**

Engineering and protocol package which seamlessly integrates ETS and Automation Builder.

#### **61850 protocol**

Adds engineering tool and library for 61850 Ed.1 MMS Server and GOOSE publish and subscribe functionalities.

#### **PCO library**

Contains process control function blocks for integration of AC500 as controller in a DCS solution. For ABB Ability™ System 800xA an object library is available which provides matching symbols and faceplates.

# PLC Automation product family

## PLCs at a glance...

AC500 Programmable Logic Controllers with scalable, state-of-the-art technology for better performance.

Standard industrial communication fieldbus, network and protocols supported by the 'One Platform' solution make the AC500 the perfect automation solution in even the most demanding

environments. Flexible and scalable superior CPUs deliver performance whenever and wherever you need it.



Secure cloud connectivity options



One programming tool for the entire AC500 PLC platform



Scalable and flexible range of products, with various communication protocol and connectivity options



Reliable, secure and safe with different performance levels



The ideal choice for high availability, extreme environments, condition monitoring, motion control or safety solutions

# AC500 PLC platform

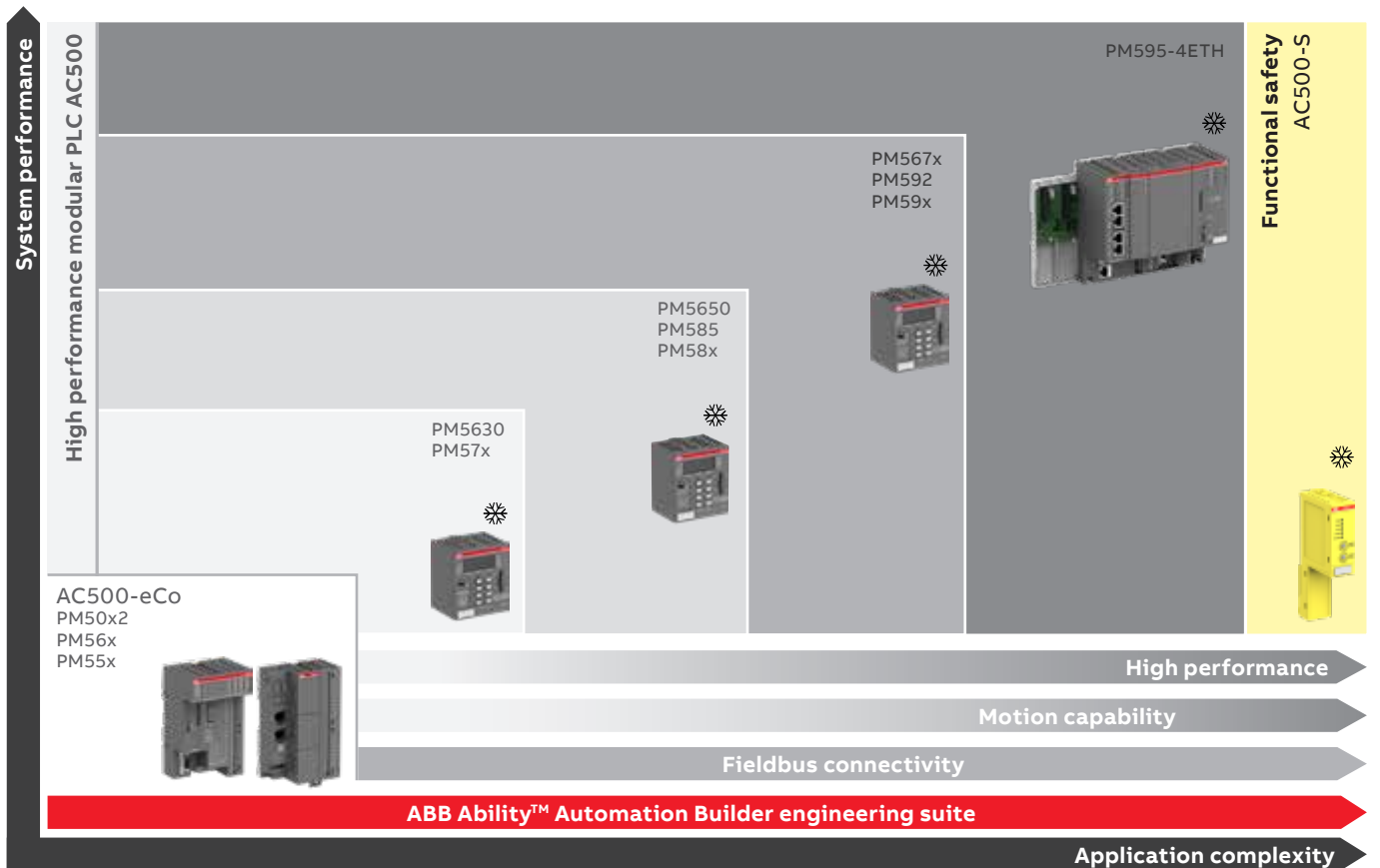



# PLC Automation product family

## PLCs at a glance...

	AC500-eCo	AC500-eCo V3	AC500	AC500 V3
<b>System configuration and application programming</b>				
Automation Builder (common programming tool)	●	●	●	●
Application Features				
Extended temperature range		● Pro W version (5)		
Extreme conditions in harsh environments				
Functional safety			●	●
Support of simple motion with FM562 module (1)	●		●	
Support of simple motion with onboard I/O PTO/PWM	●	●		
Support of PLCopen Motion Control		● (3)(5) not Basic version	●	● (3)(5)
Support of High Availability (HA) CS31 based			●	
Support of High Availability (HA) Modbus TCP based			● (4)	● (4)
Hot Swap of attached I/Os mounted on Hot Swap terminal unit			● (9)	●
<b>CPU features</b>				
	<b>AC500-eCo</b>	<b>AC500-eCo V3</b>	<b>AC500</b>	<b>AC500 V3</b>
Performance (time per binary instruction)	0.08 μs	0.20...0.02 μs	0.0006...0.06 μs	0.001...0.02 μs
Program memory	128...512 kB	1 ... 8 MB (8) thereof	128 kB...16 MB	8 ... 160 MB (8) thereof
User data memory	14...130 kB	Prog. code + Data (12) 256 kB... 1 MB	128 kB...16 MB	Prog. code + Data (12) 2 MB ... 32 MB
Remanent data (= saved)	2 kB	8... 100 kB	12 kB...3 MB	256 kB ... 1.5 MB
Serial communication				
RS232		● with option board	●	●
RS485	●	● with option board	●	●
Isolated interface	Option TA569-RS-ISO	● with option board	●	●
Modbus RTU Master/Slave	●	● with option board	●	●
CS31 protocol	●		●	
CAN communication interface on CPU				
CANopen Master, J1939 and CAN 2A/2B protocols				●
Ethernet features on CPU with integrated Ethernet or external communication module				
Online access (Programming)	● only onboard	● only onboard	●	● only onboard
ICMP (Ping), DHCP, IP configuration protocol	● only onboard	● only onboard	●	● only onboard
UDP data exchange, Modbus TCP	● only onboard	● only onboard	●	● only onboard
Ethernet features on CPU with integrated Ethernet only				
HTTP / HTTPS (integrated web server)	● / -	● / ● not Basic version	● / -	● / ●
HTML 5 Web Visu		● / ● not Basic version		●
SNTP (Time synchronization) Client / Server	● / ●	● / ●	● / ●	● / ●
FTP / FTPS server	● / -	● / ●	● / -	● / ●
FTP client	● (7)		● (7)	
SMTP client (Simple Mail Transfer Protocol)	○	● (5)	●	● (5)
IEC 60870-5-104 remote control protocol		● Pro version	●	●
MQTT for IoT connection with TLS security	● PM556/566 only	● not Basic version	●	●
Network variables on UDP		●	●	●
Socket programming		●	●	●
OPC DA (AC500 V2 and V3)	●	●	●	●
OPC UA server (AC500 V3 only)		● not Basic version		●
Selectable protocol				
BACnet (B-ASC profile)	● (4)		● (4)	
BACnet (B-BC profile)		● (4) Pro version		● (4)
KNX protocol for building communication		● (4) Pro version		● (4)
IEC 61850 protocol (MMS Server, GOOSE)		● (4) Pro version		● (4)
EtherCAT Master		● (4) (5) (11)	● (6)	
PROFINET IO Controller			● (6)	
Ethernet/IP Scanner / Adapter		● (4) (5) not Basic version		● (4)(5)
Capability to connect fieldbus modules	○ CS31, Modbus TCP	○ Modbus TCP	●	●
I/Os integrated on CPU	●	● with motion I/Os		
<b>I/O modules features</b>				
	<b>S500-eCo</b>		<b>S500</b>	<b>S500</b>
Analog modules				
Configurable			●	●
Dedicated	●	●		
Digital modules				
Configurable	○	○	●	●
Dedicated	●	●	●	●
Transistor outputs short circuit protected				
Output diagnosis			●	●
Hot Swap of I/O modules (10)			●	●
Extension with S500-eCo and S500(-XC) I/O modules	●	●	●	●

AC500-S (2)	AC500-XC	AC500-XC V3	AC500-S-XC (2)
●	●	●	●
	●	●	●
	●	●	●
●	●	●	●
●	●	●	●
●	●	● (3)(5)	●
	●		
	● (4)	● (4)	
	● (9)	●	
AC500-S (2)	AC500-XC	AC500-XC V3	AC500-S-XC (2)
0.05 μs	0.0006...0.06 μs	0.001...0.02 μs	0.05 μs
1...1.3 MB	128 kB...16 MB	8 ... 160 MB (8) thereof	1...1.3 MB
1024 kB	128 kB...16 MB	Prog. code + Data (12) 2 MB ... 32 MB	1024 kB
120 kB	12 kB...3 MB	256 kB...1.5 MB	120 kB
●	●	●	●
●	●	●	●
●	●	●	●
●	●	●	●
●	●	●	●
		●	
●	●	● only onboard	●
●	●	● only onboard	●
●	●	● only onboard	●
● / -	● / -	● / ●	● / -
		●	
● / ●	● / ●	● / ●	● / ●
● / -	● / -	● / ●	● / -
● (7)	● (7)	● (7)	● (7)
●	● (5) for V3	● (5) for V3	●
●	●	●	●
●	●	●	●
●	●	●	●
●	●	●	●
● (4)	● (4)	● (4)	● (4)
		● (4)	
		● (4)	
	● (6)		
	● (6)		
		● (4)(5)	
●	●	●	●
S500-S (2)	S500-XC	S500-XC	S500-S-XC (2)
●	●	●	●
	●	●	
●	●	●	●
●	●	●	●
●	●	●	●
● (2)	●	●	● (2)

- fully
- partly
- (1) Requires Library PS552-MC-E
- (2) AC500-S and AC500-S-XC require AC500 or AC500-XC modules to operate. The latter supports all communication interfaces.
- (3) Requires new V3 Library PS5611-MC
- (4) Licensed features, runtime license per CPU.
- (5) In preparation
- (6) PM595 and/or CPU V3 only
- (7) Application library download from "application examples"
- (8) Memory size is complete size for program, data and web server with AC500 V3 CPU, thereof size of User data and User program is smaller
- (9) As of PM585-ETH
- (10) Mounted on Hot Swap terminal unit when attached to AC500 CPU V2 as of PM585-ETH or AC500 CPU V3 or communication interface modules for Modbus TCP, PROFINET (CI501-PNIO, CI502-PNIO) or PROFIBUS.
- (11) Only Standard PM5052 or Pro PM5072 versions
- (12) Memory size of V2 versus V3 CPUs is not comparable. Projects have a different and separate User Program code and Data memory calculation in Automation Builder 2.4.0 version or later: System, configuration and web server parts are not counted anymore. This results in typically about 50% lower memory usage compared to V2, and even lower memory usage compared to V3 projects compiled in Automation Builder 2.3.0 or before.

# PLC Automation product family

## AC500 CPU Selector

### Your requirements

You are looking for a well established PLC solution with large product range for all kind of applications. You need particularly:

- Support of CS31 serial interface communication and High Availability solution with fast switching time
- Condition Monitoring capability
- Support of various types of communication protocols like PROFIBUS DP, CANopen, PROFINET, EtherCAT or serial interface protocols
- IoT connection with MQTT support
- Safety applications with support of PROFI-safe communication (F-Host and F-Device)
- PLC integration into System 800xA DCS communication

### Application specification and performance needs

#### Cost-effective application

- with compact PLC and a small number of I/Os

		AC500-eCo	
		PM5x4	PM5x6
<b>Basic</b>	<b>What does your project need?</b>		
	Compactness and onboard I/Os ?	●	●
	230 V AC power supply onboard ?	●	●
	Standard operational temperature ?	●	●
<b>Application feature</b>	Extreme environmental conditions (e.g. high temperature, humidity or vibrations) ?	-	-
	Functional Safety up to SIL3 ?	○	○
	Simple motion with PTO module FM562 / onboard I/O ?	● / -	● / -
	High-speed motion or interpolated motion ?	-	-
	Data logging ?	-	-
	Condition monitoring CMS ?	-	-
	High availability with CS31 protocol ?	-	-
	High availability with Ethernet Modbus TCP protocol ?	-	-
	HTML5 web server ?	-	-
	Telecontrol with IEC 60870-5-104 ?	-	-
Process control objects library (PCO) for DCS integration ?	●	●	
<b>Application performance</b>	More than 1 Cyclic and 1 Interrupt IEC 61131 Task ?	○	○
	4 or more IEC 61131 Tasks ?	-	-
	More than 2 kB retain variables ?	-	-
	User program / User data memory ?	128 kB / 14 kB	512 kB / 130 kB
	Large flash disk for data collecting ?	-	-
	Web server data ≤ 1MB ?	●	●
	Web server data ≥ 4MB ?	-	-
	Floating point arithmetic calculation with FPU ?	-	-
	Number of Ethernet Sockets for parallel connection ?	≤ 13	≤ 13
	Number of Modbus TCP Sockets (part of Ethernet Sockets) ?	≤ 12	≤ 12
CPU performance (ns per bit instruction) ?	80 ns	80 ns	
<b>Communication/Fieldbus</b>	Decentralized I/Os or communication on serial CS31 fieldbus ?	●	●
	Decentralized I/Os or communication on serial Modbus RTU fieldbus ?	●	●
	Decentralized I/Os or communication on PROFIBUS DP master / slave fieldbus ?	-	-
	Decentralized I/Os or communication on CAN/CANopen master / slave fieldbus ?	-	-
	Decentralized I/Os or communication on Modbus TCP network ?	●	●
	Decentralized I/Os or communication on PROFINET IO controller / device network ?	-	-
	Decentralized I/Os or communication on EtherCAT master network ?	-	-
	Two or more onboard Ethernet interfaces ?	-	-
	Onboard selectable protocols PROFINET IO / EtherCAT ?	-	-
	KNX building communication	-	-
BACnet (B-ASC profile) / BACnet (B-C profile)	-	● / -	
IEC 61850 MMS / GOOSE protocol ?	-	-	
IoT enabled with MQTT with TLS secured communication, support of JSON library	-	●	
OPC UA server ?	-	-	

- Not possible

○ Possible but not optimal solution

● Possible with additional devices

● Possible and best selection



# Automation product family

## AC500 V3 CPU Selector

### Your requirements

You are looking for a well established PLC solution with a large product range for extended features and large communication capability. You need particularly:

- Large memory and computing performance for your application
- High Ethernet capability with secured communication and support of communication network with extensive Modbus TCP communication
- IoT connection with MQTT support and OPC UA server
- Very efficient web visualization with HTML5 support
- Safety applications with local or decentralized I/O on PROFINET/PROFIsafe
- Fast coordinated motion capability from small to large CPU with embedded motion I/O or EtherCAT support

### Application specification and performance needs

- |   |   |
|---|---|
| <p><b>Extremely cost-sensitive simple application</b></p> <ul style="list-style-type: none"> <li>• with compact PLC and a small number of I/Os</li> </ul> | <p><b>Cost-effective small application</b></p> <ul style="list-style-type: none"> <li>• with compact PLC and large number of onboard I/Os</li> <li>• effective modularity with option boards</li> <li>• less-complex communication on Ethernet-based industrial fieldbus</li> <li>• IoT enabled with MQTT and OPC UA</li> <li>• web server applications</li> <li>• simple motion capability with high-speed onboard I/Os</li> </ul> |
|---|---|

		A500-eCo V3		
		Basic	Standard	
		PM5012-x-ETH	PM5032-x-ETH	PM5052-xETH
<b>Basic</b>	<b>What does your project need?</b>			
	Compactness and onboard I/Os ?	●	●	●
	230 V AC power supply onboard ?	○	○	○
	Standard operational temperature ?	●	●	●
<b>Application feature</b>	Extreme environmental conditions (e.g. high temperature, humidity or vibrations) ?	-	-	-
	Functional Safety up to SIL3 ?	○	○	○
	Simple motion with PTO module FM562 / onboard I/O ?	- / ○	- / ●	- / ●
	High-speed motion or interpolated motion ?	-	-	-
	Data logging ?	-	-	-
	Condition monitoring CMS ?	-	-	-
	High availability with CS31 protocol ?	-	-	-
	High availability with Ethernet Modbus TCP protocol ?	-	-	-
	HTML5 web server ?	-	●	●
	Telecontrol with IEC 60870-5-104 ?	-	-	-
Process control objects library (PCO) for DCS integration ?	-	-	-	
<b>Application performance</b>	More than 1 Cyclic and 1 Interrupt IEC 61131 Task ?	○	●	●
	4 or more IEC 61131 Tasks ?	-	●	●
	More than 2 kB retain variables ?	●	●	●
	Total user program memory / thereof user program code + data max.	1 MB / 256 kB (5)	2 MB / 512 kB (5)	4 MB / 768 kB (5)
	Large flash disk for data collecting ?	-	-	○
	Web server data ≤ 1MB ?	-	-	-
	Web server data ≥ 4MB ?	-	see above (2)	see above (2)
	Floating point arithmetic calculation with FPU ?	-	●	●
	Number of Ethernet Sockets for parallel connection ?	Unlimited (3)	Unlimited (3)	Unlimited (3)
	Number of Modbus TCP Sockets (part of Ethernet Sockets) ?	8	20	20
<b>Communication/Fieldbus</b>	CPU performance (ns per bit instruction) ?	20 ns	20 ns	20 ns
	Decentralized I/Os or communication on serial CS31 fieldbus ?	-	-	-
	Decentralized I/Os or communication on serial Modbus RTU fieldbus ?	●	●	●
	Decentralized I/Os or communication on PROFIBUS DP master / slave fieldbus ?	-	-	-
	Decentralized I/Os or communication on CAN/CANopen master / slave fieldbus ?	-	-	-
	Decentralized I/Os or communication on Modbus TCP network ?	●	●	●
	Decentralized I/Os or communication on PROFINET IO controller / device network ?	-	-	-
	Decentralized I/Os or communication on EtherCAT master network ?	-	-	-
	Two or more onboard Ethernet interfaces ?	-	-	-
	Onboard selectable protocols Ethernet/IP ?	-	● (1) (4)	● (1) (4)
	KNX building communication	-	-	-
	BACnet (B-ASC profile) / BACnet (B-C profile)	-	-	-
	IEC 61850 MMS / GOOSE protocol ?	-	-	-
	IoT enabled with MQTT with TLS secured communication, support of JSON library	-	●	●
	OPC UA server ?	-	●	●

- Not possible

○ Possible but not optimal solution

● Possible with additional devices

● Possible and best selection



**Small application**

- large program/data memory
- medium-complex communication via Ethernet-based industrial fieldbus
- IoT capability with MQTT and OPC UA
- building control applications with KNX
- simple or coordinated motion

**Small application**

- large program/data/web memory
- good capability for communication via standard industrial fieldbus and Ethernet-based protocols
- simple safety application local or decentralized on PROFI-safe
- coordinated motion capability on EtherCAT or CAN onboard

**Medium to large application**

- very large program/data and web server memory
- good coordinated motion capability on EtherCAT or onboard CAN
- medium to complex communication via industrial fieldbus and Ethernet-based protocols
- medium safety applications with PROFI-safe

**Extremely demanding application**

- with fast response time and complex communication with industrial fieldbus and Ethernet-based protocols
- highly-complex OPC UA communication and MQTT
- larger web server applications
- very large High Availability application with complex Modbus TCP communication
- highly-complex safety applications with PROFI-safe
- high speed and/or large coordinated motion control
- very large flash disk for data collection

	AC500 V3				
Pro					
PM5072-x-2ETH(W)	PM5630 V3	PM5650 V3	PM5670 V3	PM5675 V3	
●	○	○	○	○	○
○	○	○	○	○	○
●	●	●	●	●	●
○ (W version)	● (XC)	● (XC)	● (XC)	● (XC)	● (XC)
○	●	●	●	●	●
- / ●	- / -	- / -	- / -	- / -	- / -
● (4)	● (4)	● (4)	● (4)	● (4)	● (4)
○	○	●	●	●	●
-	-	-	-	-	-
-	-	-	-	-	-
●	●	●	●	●	●
●	●	●	●	●	●
●	●	●	●	●	●
-	-	-	-	-	-
●	●	●	●	●	●
●	○	●	●	●	●
●	●	●	●	●	●
8 MB / 1 MB (5)	8 MB / 2 MB (5)	80 MB / 8 MB (5)	160 MB / 32 MB (5)	160 MB / 32 MB (5)	
○	○	○	○	8GB	
-	○	○	○	○	
see above (2)	see above (2)	see above (2)	see above (2)	see above (2)	
●	●	●	●	●	
Unlimited (3)	Unlimited (3)	Unlimited (3)	Unlimited (3)	Unlimited (3)	
30	30	50	120	120	
20 ns	20 ns	10 ns	2 ns	2 ns	
-	-	-	-	-	
●	●	●	●	●	
-	● / ● (1)	● / ● (1)	● / ● (1)	● / ● (1)	
-	● / -	● / -	● / -	● / -	
●	●	●	●	●	
-	● / ●	● / ●	● / ●	● / ●	
○ (1) (4)	●	●	●	●	
●	●	●	●	●	
● (1)(4)	● (1)(4)	● (1)(4)	● (1)(4)	● (1)(4)	
● (4)	● (4)	● (4)	● (4)	● (4)	
- / ● (4)	- / ● (4)	- / ● (4)	- / ● (4)	- / ● (4)	
● (4)	● (4)	● (4)	● (4)	● (4)	
●	●	●	●	●	
●	●	●	●	●	

(1) In preparation  
 (2) Total memory for code, data and web server with AC500 V3 CPU, thereof size of User data and User program is smaller and dynamically allocated  
 (3) Number of ETH Socket total is basically not limited, but depends on: CPU load, priority of application tasks, kind of used protocols, amount of data transferred, network structure  
 (4) Feature(s) is (are) licensed, runtime license per CPU.  
 (5) Memory size of V2 versus V3 CPUs is not comparable. Projects have a different and separate User Program code and Data memory calculation in Automation Builder 2.4.0 version or later. System, configuration and web server parts are not counted anymore. This results in typically about 50% lower memory usage compared to V2, and even lower memory usage compared to V3 projects compiled in Automation Builder 2.3.0 or before.

# PLC Automation product family

## AC500-eCo – modular concept

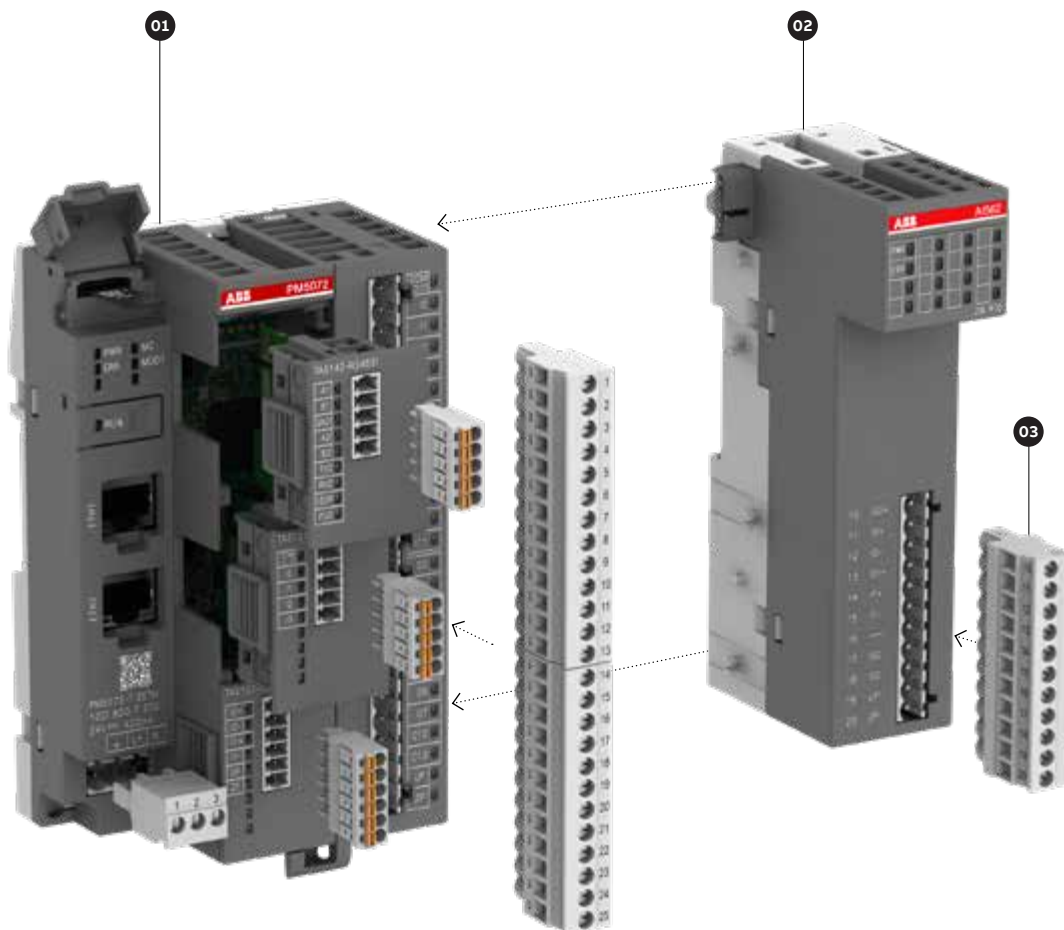

### 01 – AC500-eCo central processing unit (CPU)

- Different memory options
- Different CPU types and performances
- Integrated communication option
- Onboard I/O extension using option board slots of AC500-eCo V3 CPU
- Ethernet-based communication.

### 02 – S500-eCo I/O modules

- Up to 10 modules
- Decentralized extension available.

### 03 – Terminal blocks

- Three types of pluggable terminal blocks available for AC500-eCo V2 and S500-eCo I/O modules
- Two types of terminal block sets for AC500-eCo V3.

# PLC Automation product family

## AC500 and AC500-XC – modular concept

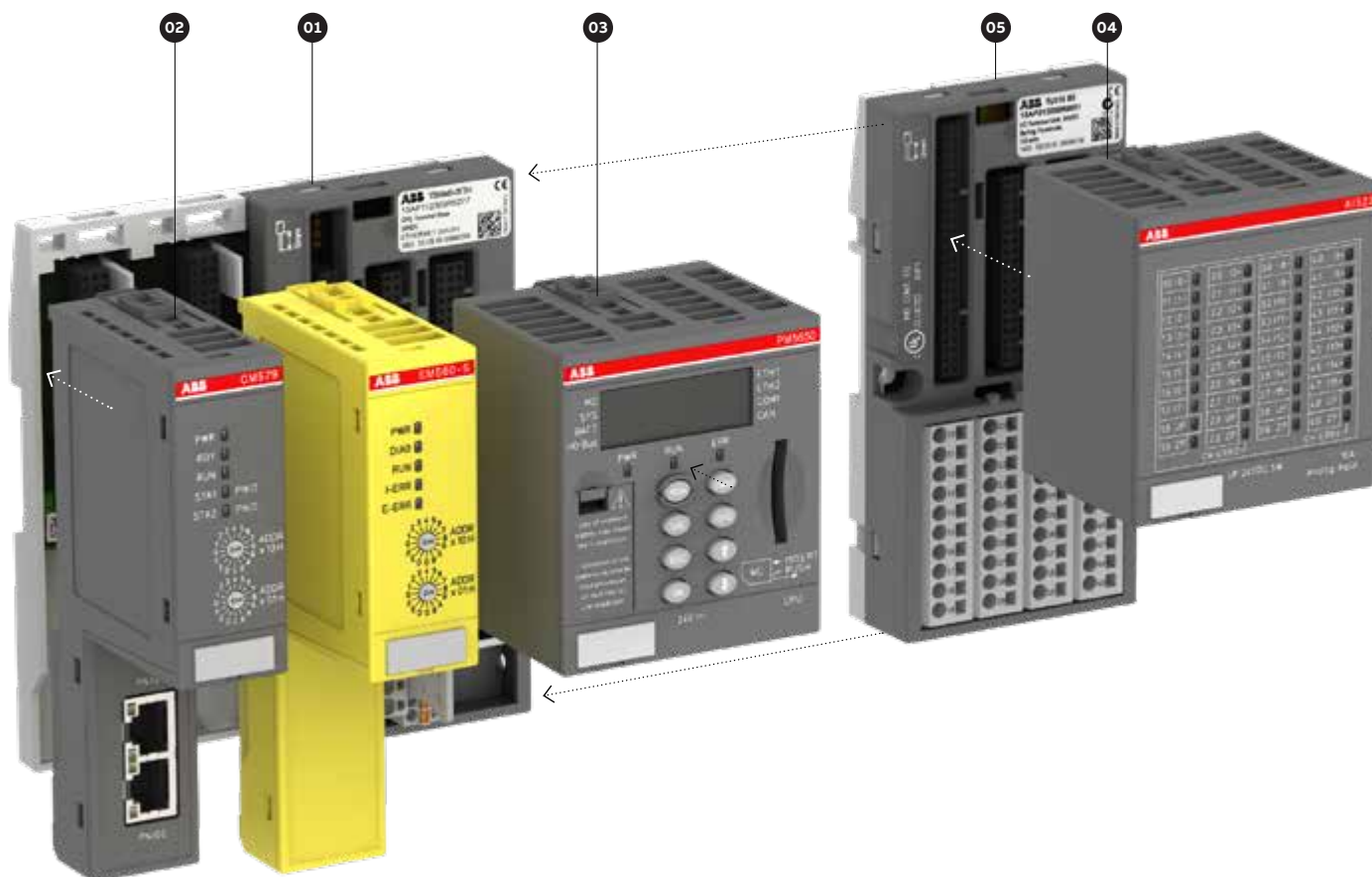

### 01 – Terminal base

- Common for all AC500 V2 CPU types
- For 1, 2 or 4 communication modules
- With serial interfaces
- With 1 or 2 Ethernet interfaces
- New specific terminal base only for AC500 V3 CPU with 0, 1, 2, 4 and 6 communication modules.

### 02 – Communication modules

- For PROFIBUS DP, Ethernet, Modbus TCP, EtherCAT, CANopen, PROFINET IO or serial programmable
- Up to 4 pluggable
- Up to 6 pluggable for AC500 V3 CPU
- Support of AC500-S safety solution.

### 03 – AC500 central processing unit (CPU)

- Different performance, memory, network, operating conditions options
- Integrated communication
- New AC500 V3 CPU with large memory and high performance (requires new specific terminal base).

### 04 – S500 I/O modules

- Up to 10 modules
- Decentralized extension available
- Hot swap I/Os local or decentralized on PROFINET IO and additionally PROFIBUS DP for V2.

### 05 – Terminal units

- Up to 10 terminal units
- Decentralized extension available.

# PLC Automation product family

## AC500-eCo system characteristics

Locally, AC500-eCo CPUs can be extended with up to 10 I/O modules. AC500-eCo CPUs with different performance levels are available.

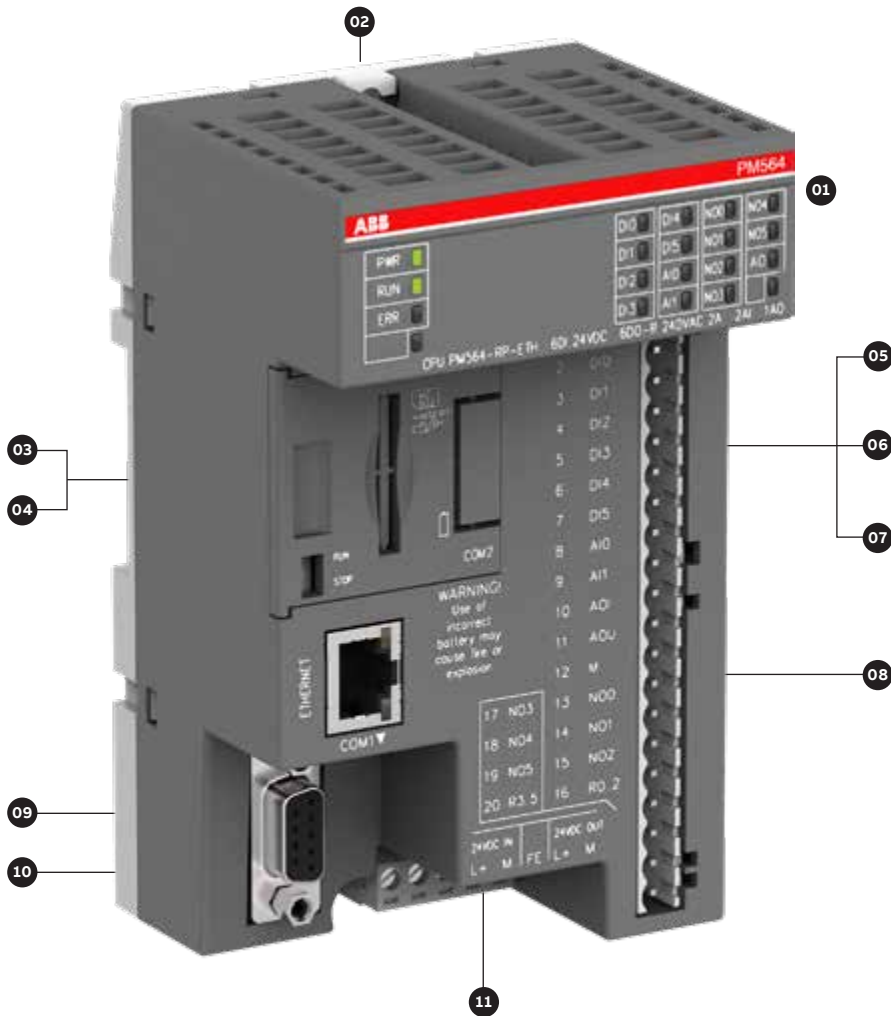

—  
01 AC500-eCo CPUs are locally extendable with up to 10 I/O modules (standard S500 and S500-eCo I/O modules can be mixed).

—  
02 Wall mounting

—  
03 Memory card adapter

—  
04 Memory card

—  
05 Adapter with realtime clock

—  
06 Adapter with COM2 & realtime clock

—  
07 Adapter with COM2

—  
08 Terminal blocks

—  
09 RS485 isolator for COM1

—  
10 COM1 USB

—  
11 COM2 USB programming cable

—  
12 AC500-eCo Starter kit. For more information, see page 259

—  
13 Input simulator



01



02



03



04



05



06



07



08



09



10

11



12

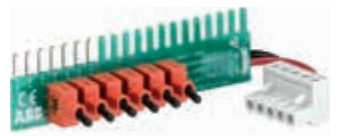

13

# PLC Automation product family

## AC500-eCo V3 system characteristics

The new AC500-eCo V3 Basic, Standard and Pro CPUs are available with different performance levels. For digital and analog I/O or communication extension, option boards can be used. Locally, AC500-eCo V3 Standard and Pro CPUs can be extended with up to 10 I/O modules.

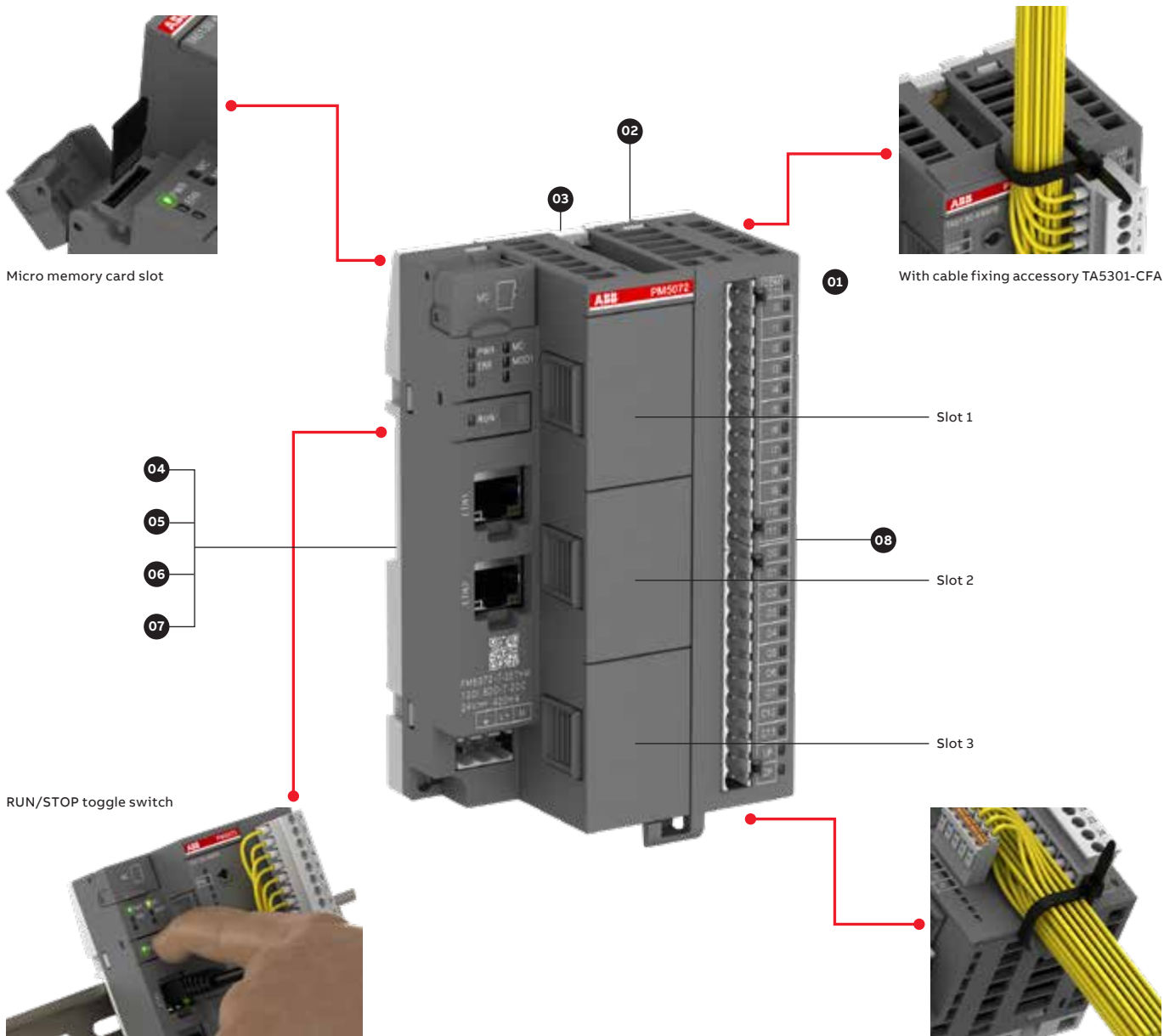

	Basic	Standard	Pro
	PM5012-x-ETH	PM5032-x-ETH	PM5052-x-ETH
Option board slot 1	●	●	●
Option board slot 2	-	●	●
Option board slot 3	-	-	●



— 01 AC500-eCo V3 Standard and Pro CPUs are locally extendable with up to 10 I/O modules (standard S500 and S500-eCo I/O modules can be mixed).

— 02 Cable fixing adapter

— 03 Wall mounting

— 04 Option boards for digital I/O extension

— 05 Option boards for analog I/O extension - in preparation

— 06 Option boards for COMx serial communication

— 07 Option boards KNX address push button or slot cover

— 08 Terminal block sets

— 09 AC500-eCo Starter kit. For more information, see page 259

— 10 Input simulator

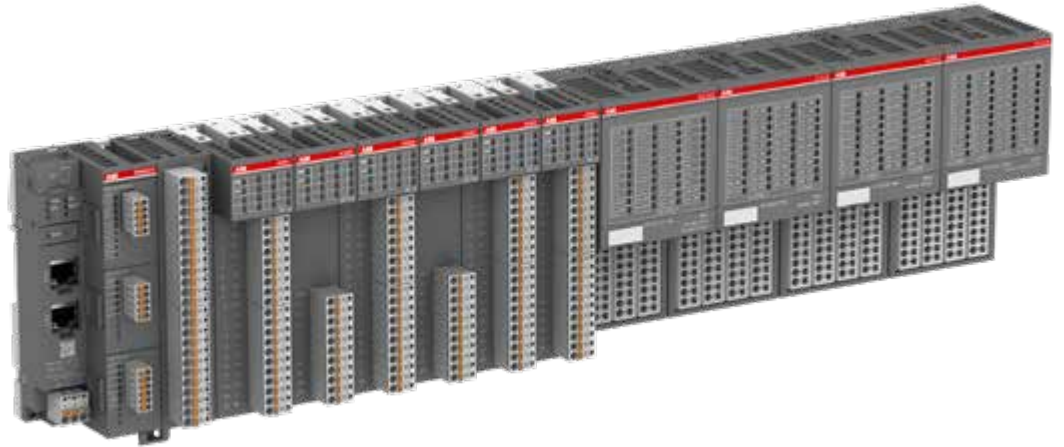

— 01



— 02



— 03



— 04



— 05



— 06



— 07

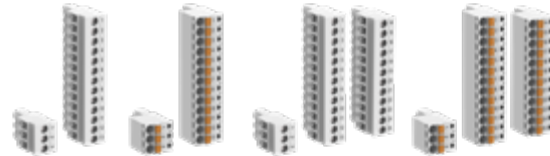

— 08



— 09





— 10

# PLC Automation product family

## AC500-eCo V3 overview

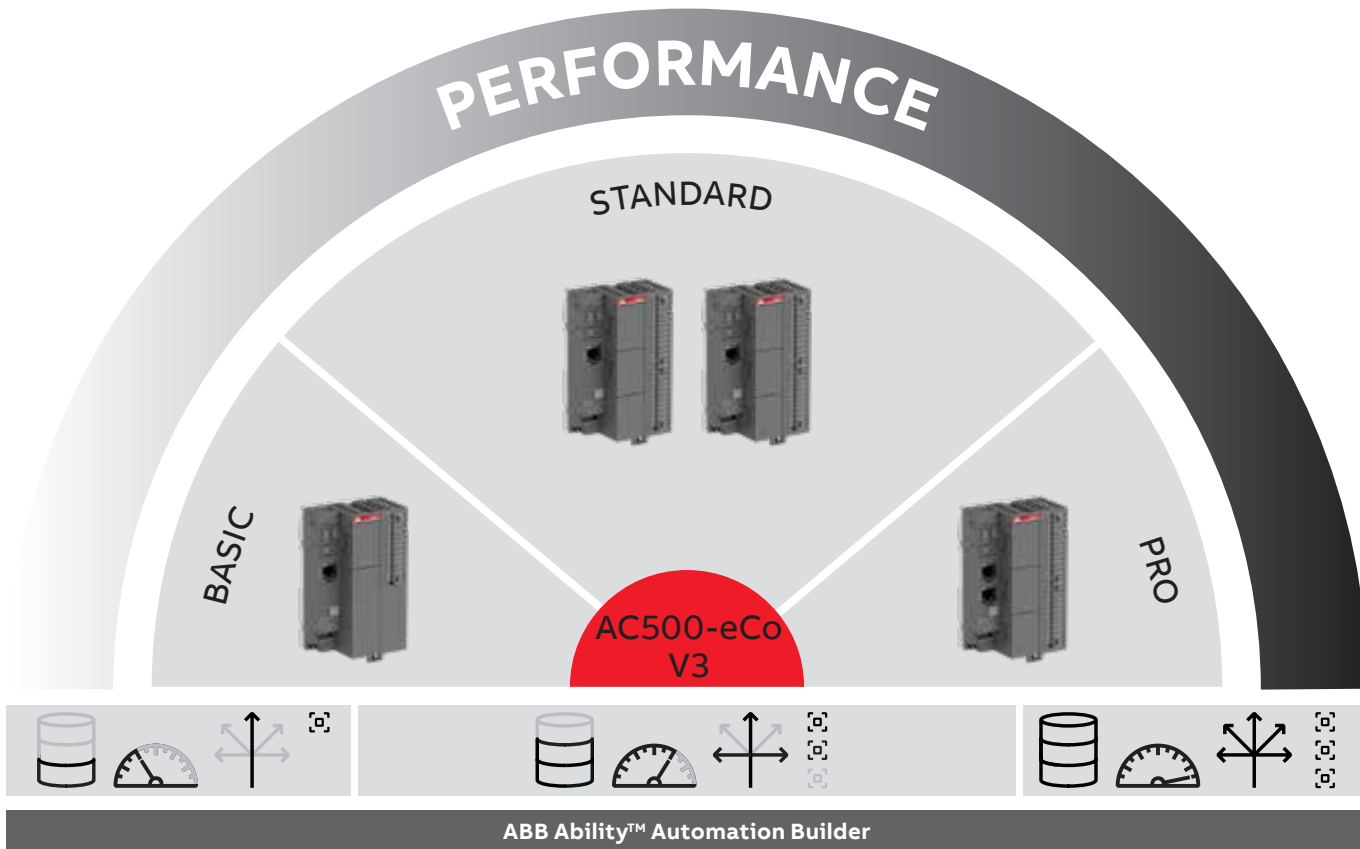
More AC500-eCo features but the same footprint



- 

Memory
- 

Performance
- 

Connectivity
- 

Option board

**BASIC****STANDARD****PRO****Basic****Basic and compact applications**

- For extremely cost-sensitive and simple applications
- Few I/O channels only
- Ethernet communication
- Easy onboard extension with one option board, no I/O-bus
- Adequate performance
- Benefits from the ABB Ability™ Automation Builder software platform

**Standard****For modular and distributed applications**

- Powerful processor with integrated Floating Point Unit for fast calculation
- Ethernet interface on all the products for all-purpose communication (e.g. Modbus TCP, Ethernet/IP (1) (2))
- Web server with HTML5 web visualization
- IoT-enabled with OPC UA server
- MQTT protocol
- High modularity with up to 3 option boards for I/O extension and communication
- High-speed onboard I/Os with simple motion capability
- Larger number of I/Os with modular extension
- Reuse of existing S500/S500-eCo I/O modules

**Pro****For demanding logic, motion and IoT-ready applications**

- Powerful CPU for communication, gateway to IoT applications or motion control
- Larger memory for big applications and web capability
- 2 independent Ethernet interfaces with switch function
- A variety of Ethernet-based protocols
  - For building applications (KNX (1)/BACnet (1)(2))
  - Telecontrol (IEC 60870-5-104)
  - Energy management (IEC 61850 (1))
  - Motion control (EtherCAT (1)(2))
  - SCADA connection
- Coordinated motion with PLCopen library (1)(2) and EtherCAT (1)(2)

(1) Runtime license per CPU required.  
(2) In preparation

Please watch our videos on our ABB PLC YouTube channel:



[www.youtube.com/user/abbplc](https://www.youtube.com/user/abbplc)

# PLC Automation product family

## AC500 system characteristics

AC500 offers superior local extension capabilities for I/O communication, best-in-class CPU functionality and industry-leading performance.



—  
01 AC500 CPUs are locally extendable with up to 10 I/O modules (standard S500 and S500-eCo I/O modules can be mixed).

—  
02 Terminal base / Terminal base V3

—  
03 Communication module  
Up to 4 modules for multiple combinations to communicate on nearly every protocol available  
Up to 6 modules can be used with AC500 V3 CPU

—  
04 CPU module / CPU V3 module

—  
05 S500 Terminal unit

—  
06 S500 I/O module

—  
07 Pluggable marker holder for S500 I/O modules with template

—  
08 S500-eCo I/O module

—  
09 Memory card

—  
10 Battery



—  
01



—  
02



—  
03



—  
04



—  
05



—  
06



—  
07



—  
08



—  
09



—  
10

# PLC Automation product family

## AC500 PM595 controller system characteristics

The flagship of the AC500 platform, the AC500 PM595 controller, was designed to be as scalable, flexible and efficient as the entire AC500 range.

With the AC500 CPU PM595, ABB launched a new core for machine control applications. Its high-performance processor with generous memory offers performance, security and reliability for the upcoming challenges of automation applications.

A variety of connectivity capabilities, integrated safety and utilizability even under rough environment provide machine builders with valuable benefits when performing their automation tasks.

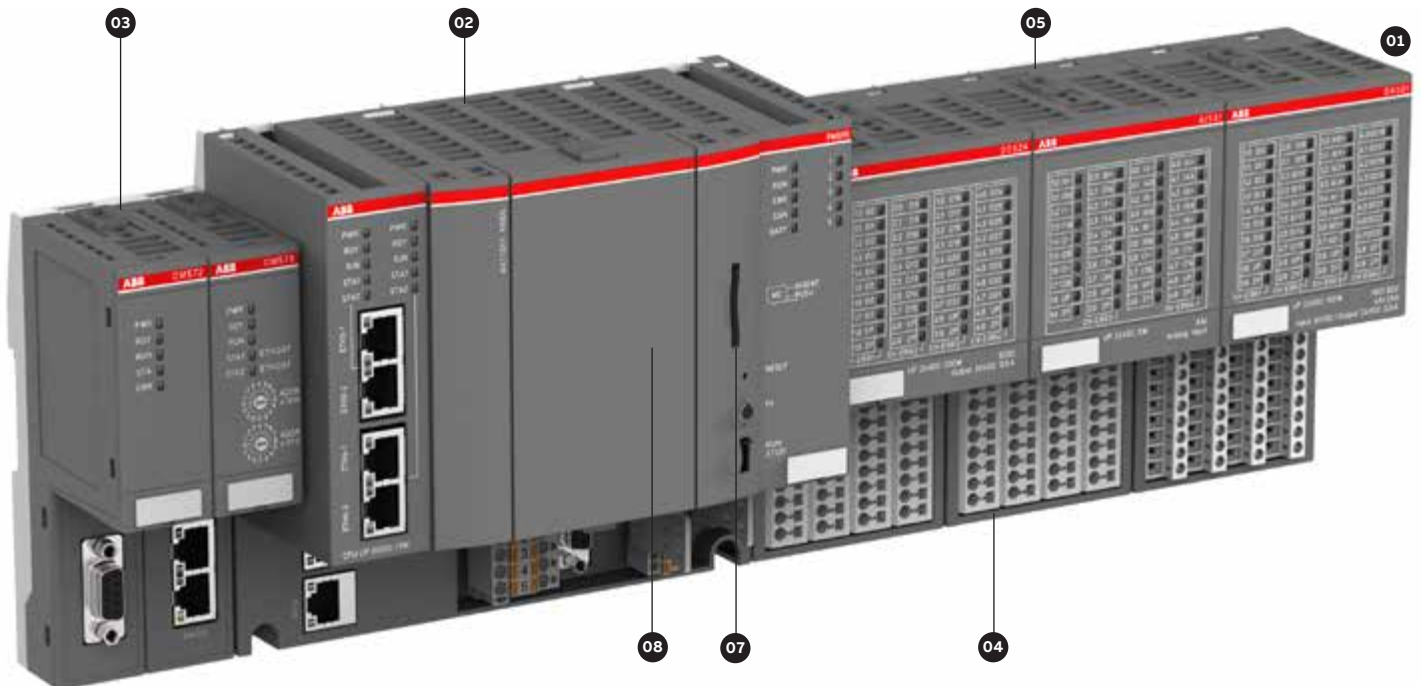



—  
01 AC500 CPUs are locally extendable with up to 10 I/O modules (standard S500 and S500-eCo I/O modules can be mixed).

—  
02 CPU with integrated connectivity and terminal base

—  
03 Communication module.  
Up to 2 modules for multiple combinations to communicate on nearly every protocol available and to include functional safety

—  
04 S500 Terminal unit

—  
05 S500 I/O module

—  
06 S500-eCo I/O module

—  
07 Memory card

—  
08 Battery

—  
09 Pluggable marker holder for S500 I/O modules with template



01



02



03



04



05



06



07



08



09

# PLC Automation product family

## Condition monitoring system CMS based on AC500

Predictable performance for your operations

Optimize your assets with a condition monitoring system (CMS) based on the proven AC500 platform. The FM502 module can help you to improve your operations resulting in greater efficiency and higher reliability while minimizing service and operating costs.



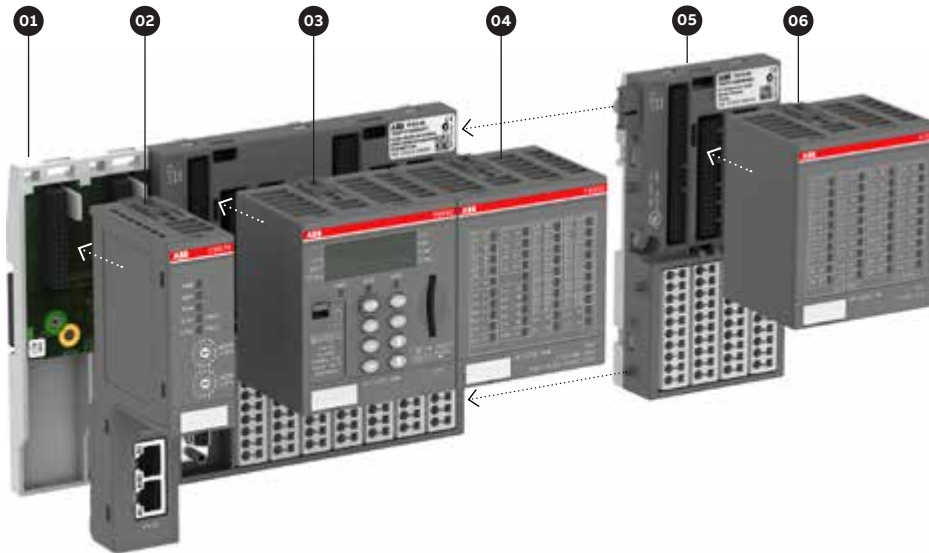

- 01 Terminal base: TF501 or TF521
- 02 Accomodating: 0 - 2 communication modules
- 03 PM592 CPU
- 04 FM502 CMS module
- 05 Extendable by I/O terminal units
- 06 Extendable by further I/O modules

**Add predictable performance and productivity**  
 The CMS module brings further reliability and easy integration with all kinds of machinery systems, enabling precise management of the real-time condition of your operation. This transparency takes your business and productivity to a new level with more efficient machines, predictable performance and significant reduction in maintenance costs.

No matter whether as stand-alone condition monitoring or integrated into machine or process control, the module is perfectly suited to build optimized, self-analyzing automation solutions that simultaneously perform condition monitoring, control, protection, safety and data logger functions with one controller. The fast data logger function also contributes to consistent high quality production, due to the possibility to combine control and production information directly.

CMS also protects against machine failures, unforeseen sudden damage, incorrect installation, and reduces maintenance and wear. Virtually no unscheduled downtimes boost plant availability and reliability.

**Advantages**

- Planned maintenance rather than spontaneous repair ensures predictable performance
- Approaching damage is identified very early
- Protection against spontaneous failures and operation in critical conditions
- Reduction of costs in maintenance and lost production time
- Plant availability is increased
- Optimum utilization of the aggregates until real end of life
- Simple to use, maintain, adapt or extend

**AC500 + CMS = increased machine efficiency**

All based on the AC500 platform modularity provides ultimate flexibility: Communication and I/O modules can be added and combined with Safety.

**Extendable, robust and proven**

- Stand-alone CMS or control integrated
- Can be extended by AC500 communication modules and S500 I/O modules
- Proven and future proof, as based on AC500 platform
- Extreme conditions XC version available
- Fast data logger, e. g. for production quality
- Condition monitoring and fast protection (vibration, current, voltage, speed/encoder)

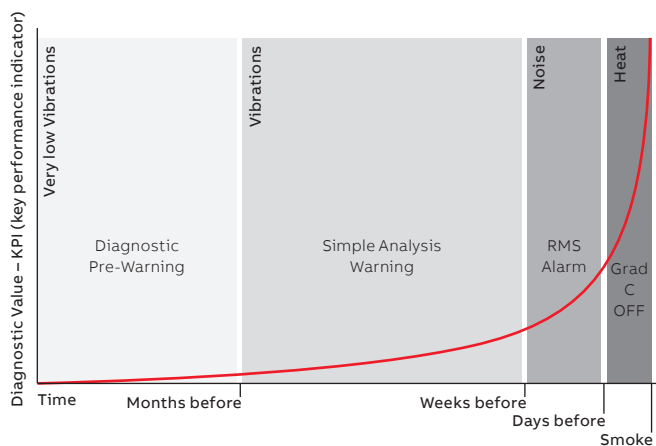

# PLC Automation product family

## AC500 V3 enhanced connectivity and performance

The new V3 features provide even more flexibility and freedom when it comes to connectivity and functions supplied onboard without the need of additional devices as couplers or switches. AC500 V3 is ready for the requirements of IoT and digitalization and secure cloud connectivity via new protocols and functions.

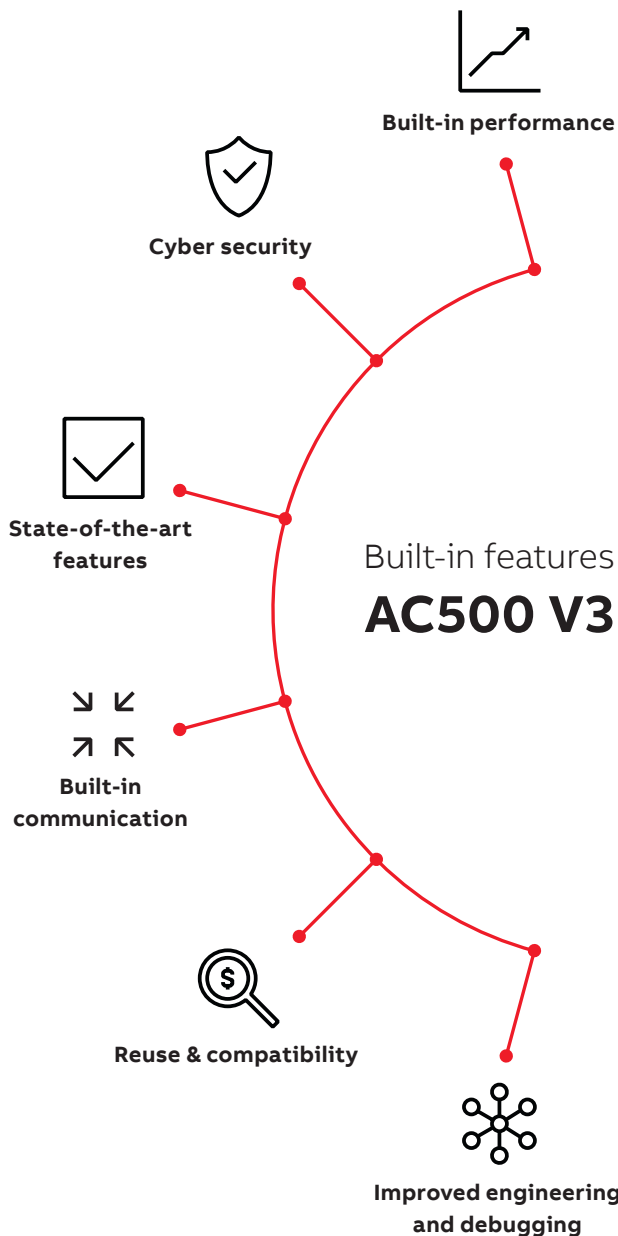

### Built-in performance

- Faster CPUs with more powerful processors
- More CPU memory allocated freely
- Modern, state-of-the-art components

### Cyber security

- Digitally signed firmware updates protected by hardware security chip
- Secure communication protocols: HTTPS, FTPS, OPC UA, MQTT
- Encrypted communication with engineering system ABB Ability™ Automation Builder and boot application

### State-of-the-art features

- OPC UA for easy connectivity to SCADA systems or operator panels
- MQTT for lightweight cloud messaging
- Onboard HTML5 web server technology
- Functional safety support with PROFIsafe communication

### Built-in communication

- Two Ethernet interfaces for use as switch or independent ports
- Onboard Ethernet protocol as Ethernet/IP\*
- CANopen master interface, CAN2A/2B, J1939
- KNX and BACnet
- OPC UA server, OPC DA alarm and event
- IEC 61850
- IEC 60870-5-104 Telecontrol

### Reuse & compatibility

- Reuse with AC500 platform:
  - S500/S500-eCo I/O modules
  - Communication modules
- Project conversion and code re-use

### Improved engineering and debugging

- Professional version control with subversion
- Application project management
- Object-oriented programming
- Optimized IEC 61131-3 editors
- Offline simulation capabilities\*

\* In preparation

The flexibility, scalability and footprint of AC500 V2 have been passed on to the new CPU range. Therefore, AC500 continues to be the perfect fit for various applications or will be the natural

successor when you need to introduce new features to existing applications or extend machines and applications to reach for the cloud.

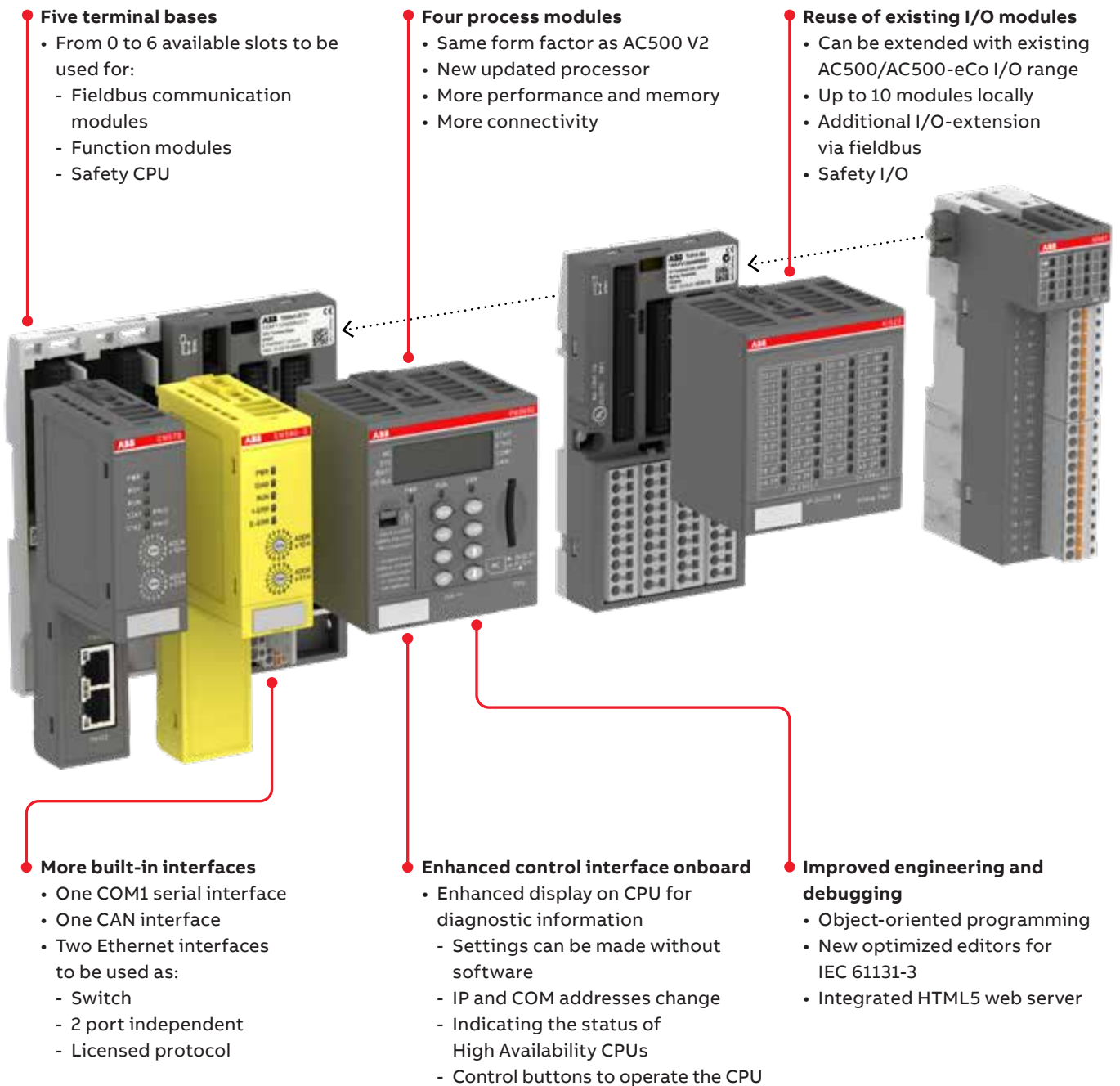



# PLC Automation product family

## AC500 extreme conditions

AC500-XC – the rugged variant of AC500 for extreme indoor and outdoor conditions.

The PLC AC500-XC is reliable, functionally safe and operational even under rough environmental conditions.







04



01



02



03



05



06

- 01 Terminal base
- 02 Extreme conditions communication module
- 03 Extreme conditions CPU
- 04 Extreme conditions CPU with integrated connectivity and terminal base
- 05 Extreme conditions S500 terminal unit
- 06 Extreme conditions S500 I/O module



**Operation in extremely humid environments**

- Increased resistance against 100 % humidity and condensation.



**Extended operating temperature**

- -40 °C up to +70 °C operating temperature.



**Reliable in high altitudes**

- Operation in altitudes up to 4000 m above sea level or air pressures up to 620 hPa.



**Extended immunity to corrosive gases and salt mist**

- G3, 3C2 / 3C3 immunity
- Salt mist EN 60068-2-52 / EN 60068-2-11.



**Extended immunity to vibration**

- 4 g rms random vibration up to 500 Hz
- 2 g sinusoidal vibration up to 500 Hz.



**Extended EMC requirements**

- EN 61000-4-5 surge immunity test
- EN 61000-4-4 transient / burst immunity test.

# PLC Automation product family

## AC500-S safety PLC – functional safety

AC500-S safety PLC is the solution for both simple and complex machine and process safety applications requiring maximum reliability, efficiency and flexibility.

This safety PLC protects people, machines and processes, the environment and investments – the ideal choice for hoist, wind turbine, crane, material handling, robot and other factory and process applications.

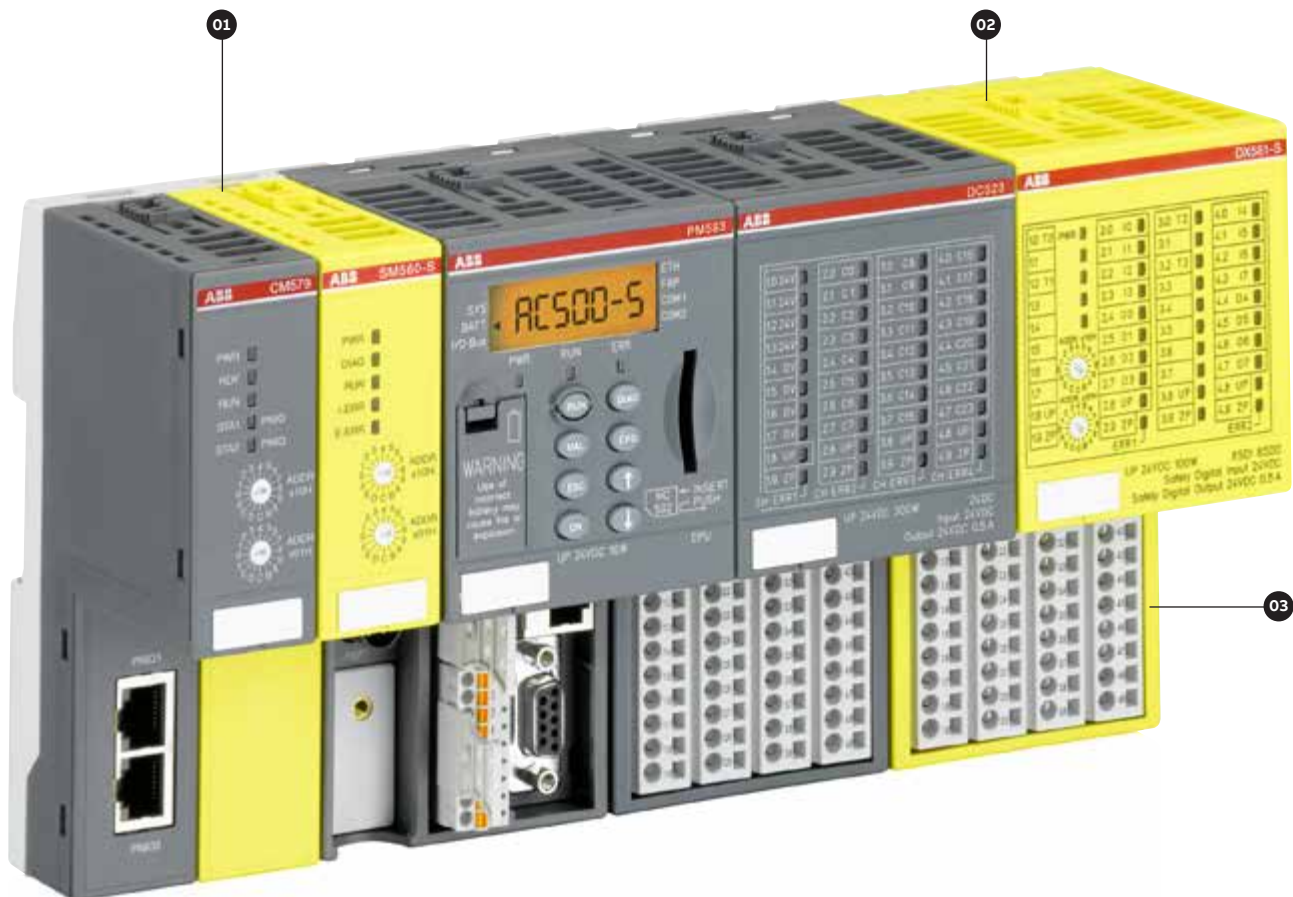



01



02



03

- 01 Safety CPU
- 02 S500 Safety I/O module
- 03 Safety terminal unit

**Better integration and ease of programming**

Featuring a consistent look and feel across the entire range, the AC500 is the PLC of choice for applications where uncompromised flexibility, comprehensive integration and seamless communication are a must.

ABB Ability™ Automation Builder seamlessly integrates your safety application in ABB PLC, Safety, Drives, Motion and HMI. Through integrated standard languages, such as IEC 61131-3, Automation Builder is easy to use, thus, allowing you to get started in virtually no time at all. And what is more: intuitive system configuration using one single tool ensures optimal transparency.

The AC500-S safety PLC facilitates the implementation of even most complex safety applications. Support of safety-relevant calculations, such as COS, SIN, TAN, ASIN, ACOS and LOG makes the AC500-S the ideal solution for crane engineering, wind power generation, robotics and hoisting applications.

Safety programming with Structured Text (ST) and full support for Function Block Diagram (FBD) and Ladder Diagram (LD) programming and advanced features in PROFI-safe over PROFINET communication, like Shared Device functions, gives you greater flexibility and simplifies safety application development. The AC500-S safety PLC is also available in a version for extreme conditions.

# PLC Automation product family

## Visualization options

PB610 Panel Builder 600 in combination with the CP600 HMI platform provides flexible possibilities for visualization.

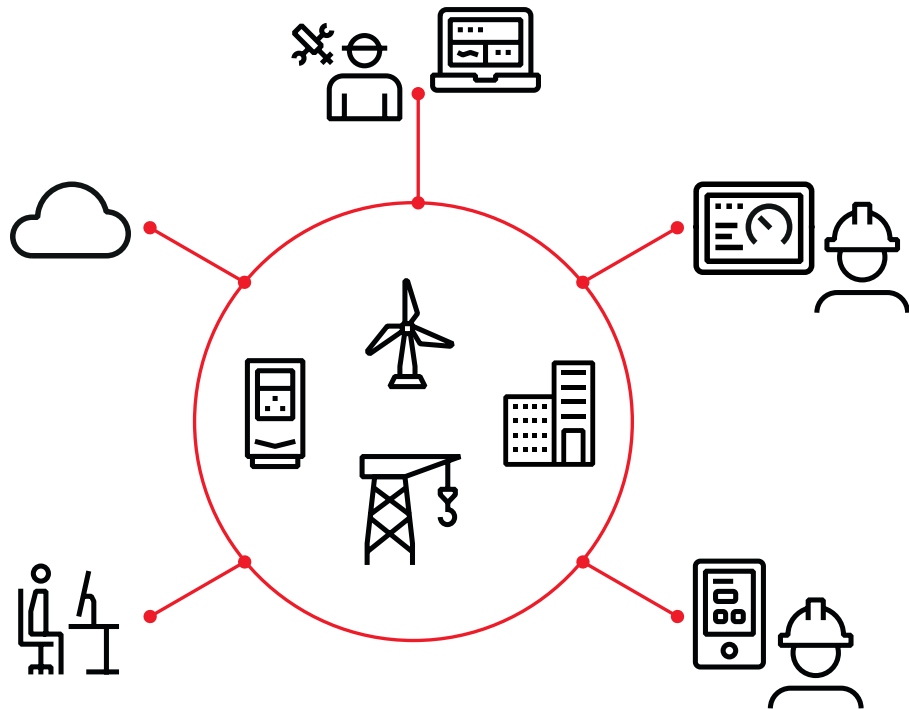

### Your interface to the application

Whether you prefer to use your smart device anywhere, stand in front of a control panel at your application or want to inform yourself about an installation abroad e.g. via the cloud: CP600 platform control panels with PB610 Panel Builder 600 provide you with the free selection of how to get the information you need, let you operate your application easily and support the effective analysis of your processes.

### Tailor-made for easy, intuitive operation

PB610 Panel Builder 600 supports the design of easy to use and reliable to operate graphical user interfaces for all control panels of the CP600 platform, mobile smart devices and notebooks. Standardized faceplates are easily realized by means of so called custom widgets and structured tags.

### User management and cyber security

Configuration of users and user groups allows to define access rights and permissions for and from different devices and media according to your needs. Devices and software are regularly tested accordant latest known possible vulnerabilities.

### Web panels

CP600 control panels with PB610 provide web servers for HTML5 based visualization on various users' devices. The majority of the control panels comes with a browser for using them for

- visualization of AC500 web server (V3)
- nearly unlimited information through general web access
- easy combination of PB610 user interface with information from the web.

### Mobile / remote access to HMI

HTML5 based graphical user interfaces enable remote access and operation via mobile devices like smartphones, tablets etc.

# PLC Automation product family

## PB610 Panel Builder 600



### Engineering tool for easy design of tailor-made graphical user interfaces for the entire CP600 platform

PB610 Panel Builder 600 software is integrated in the ABB Ability™ Automation Builder engineering suite and can be downloaded via Automation Builder installer.

Tailor-made human machine interface (HMI)

- For the efficient design of flexible HMI applications in versatile automation solutions.
- Vector graphics (\*.SVG) for precise, easily scalable and dynamic HMI design.
- Alpha blending for realistic transparency effects.

- Libraries including rich sets of widgets – ready-to-use graphical objects.
- Easy creation of customized widgets through the combination/modification of standard widgets.
- Customized widgets clearly arranged in user galleries.
- Page templates for professional design.
- Numerous configuration options for all HMI elements.
- Realization of customized functions and individual dynamic manipulation via Java Script with debugger.
- Easy data acquisition and trend presentation.
- Reliable user management and secure access control.
- Rich set of configurable features: dynamic objects, data acquisition, alarm handling, multi-language applications, recipes, ...
- HMI simulation for efficient commissioning.
- Numerous drivers for easy connection to e.g. PLCs, drives, robots.
- OPC UA client and server for future-orientated cloud connectivity and IoT.
- Gateway function for easy data exchange between different protocols and systems.



# PLC Automation product family

## CP600 control panels platform at a glance ...

With comprehensive but easy-to-use functionalities, ABB control panels stand out from competitor products. At one single touch, they intuitively provide operators with tailor-made operational

information for production plants and machines. CP600-eCo, CP600 and CP600-Pro control panels make machine operation efficient, predictable and user-friendly.

New comprehensive CP600 control panels platform for different applications

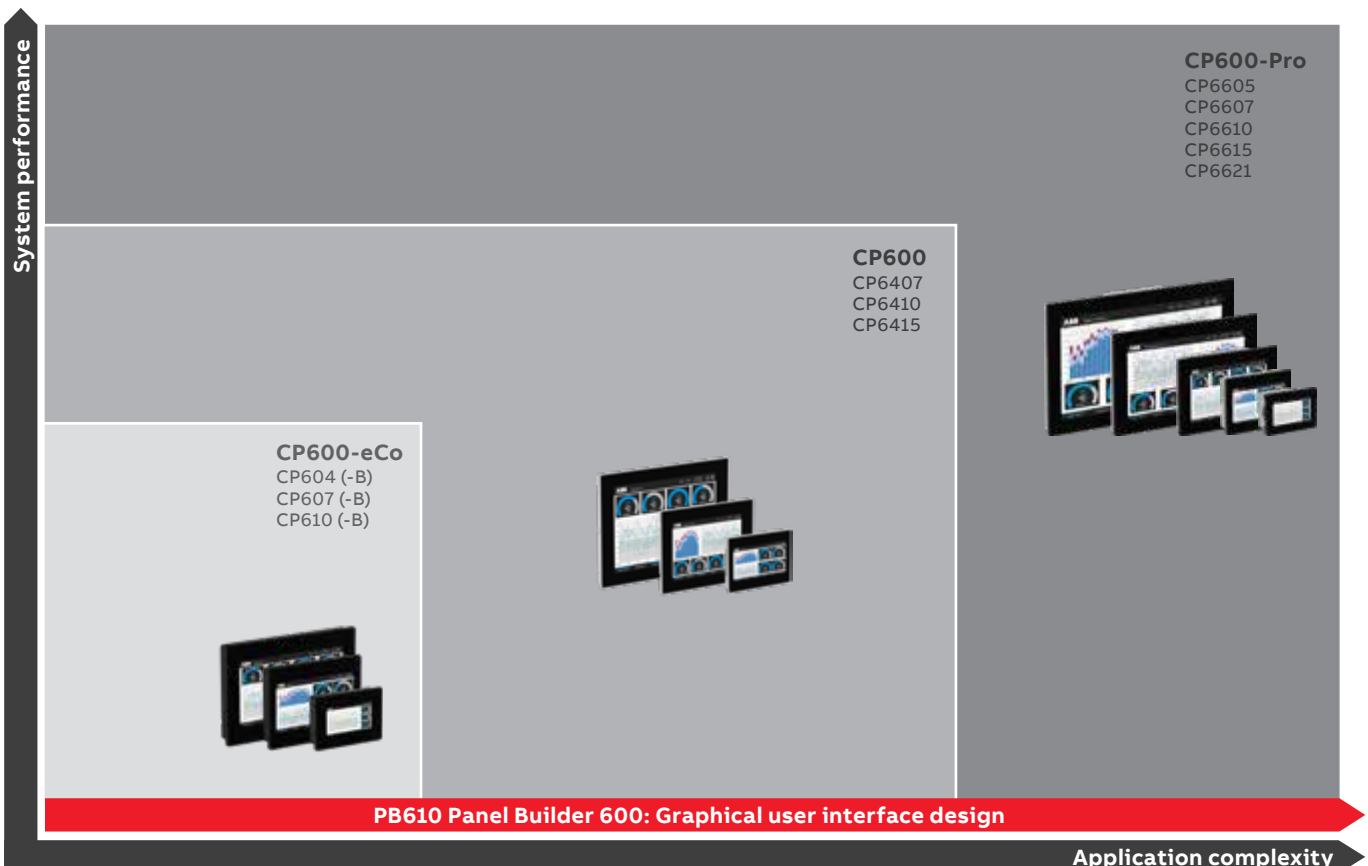

**CP600-eCo, CP600, CP600-Pro**

Wide range of control panel offerings in three assortments. Ideal choice for visualization of AC500 PLC platform automation solution.

The economical CP600-eCo control panel is aimed for standard functions and high usability for clear interaction with the operation process.

The robust CP600 HMI provides state-of-the-art performance, versatile communication and representative design for machines and systems.

The CP600-Pro HMI comes with high end visualization performance, multi-touch operation, versatile trendsetting communication and representative design.

Due to the good scalability between CP600-eCo, CP600 and CP600-Pro, CP600-eCo HMI applications can be re-used easily for CP600 or CP600-Pro control panels and vice versa.



**PB610 Panel Builder 600**

PB610 Panel Builder 600 is the engineering tool for the entire CP600 control panels platform. PB610 Panel Builder 600 software is integrated in the ABB Ability™ Automation Builder engineering suite. For integration into a couple of third party automation systems, drivers are available. OPC UA client and server support future-orientated communication solutions.

**CP600 platform selection guide for tailor made HMI applications**

CP600-eCo	for PB610 HMI applications; CP610: Or visualization of AC500 V3 web server (*)
CP600	for PB610 HMI applications or visualization of AC500 V3 web server
CP600-Pro	for PB610 HMI applications or visualization of AC500 V3 web server

(\*) Supported by products with revision index C1 or higher

**What does your application need ?**

	CP600-eCo	CP600	CP600-Pro
Screen sizes	sizes from 4" to 10" 4.3", 7", 10.1"	sizes from 7" to 15" 7", 10.4", 15"	wide range from 5" to 21" 5", 7", 10.1", 15.6", 21.5"
Operation	single-touch	single-touch	multi-touch
Communication	1 SER, 1 ETH, 1 USB	1 SER, 2 ETH, 2 USB, 1 SD	1 SER, 3 ETH (1), 2 USB (2), 1 SD
Operating temperature	0...50 °C	-20...+60 °C	-20...+60 °C
Enclosure	plastic / glass + front foil	aluminium / glass + front foil	aluminium / real glass
Operating system	Linux	Linux	Linux
PB610 application	60 MB	150 MB	240 MB (3)

(1) CP6605: 2 ETH  
 (2) CP6605: 1 USB  
 (3) CP6605: 60 MB

# PLC Automation product family

## CP600-eCo control panels



### Economic HMI range for basic applications

Control panels in three different screen sizes from 4.3" to 10.1" in ABB design or just black provide HMI functions typically required for basic applications. The engineering tool PB610 Panel Builder 600, part of Automation Builder, ensures easy scalability on the CP600 platform.

### Designed for basic applications

- The widescreens available in 4.3", 7" and 10.1" are suitable for many applications.
- Protocols for ABB PLCs, machinery and motion drives for Ethernet and serial connection make these control panels first choice for ABB automation solutions.
- OPC UA client and server functions make them well prepared for future communication solutions.
- Engineering by means of PB610 Panel Builder 600, part of Automation Builder, facilitates integration into automation packages and enables good scalability on the CP600 platform for different applications.

### Slim industrial design

The slim plastic enclosure in attractive industrial design with a mounting depth of 29 mm enables installation even in narrow spaces. All connectors are located on one side. Landscape and portrait mounting options provide installation flexibility and various HMI presentations. These devices are available either in ABB design or in black.

### State-of-the-art connectivity

- Ethernet interface 10/100 Mbit for easy connectivity to ABB automation components.
- Flexible serial connectivity to automation components without Ethernet interface.
- USB host for flexible data storage and easy updating.



---

The CP600 platform is many customers' first choice for their individual visualization projects.

# PLC Automation product family

## CP600 control panels



### State-of-the-art HMI range for diverse applications

The CP600 control panels in screen sizes of 7", 10.4" and 15" provide comprehensive HMI functions for a wide range of applications. The engineering tool PB610 Panel Builder 600, part of Automation Builder, ensures easy scalability on the CP600 platform. Same front dimensions, cutouts and screen resolutions support an easy replacement of former CP600 control panels.

### Tailor-made for your needs

- Three different screen sizes with standard aspect ratio or widescreen from 7" to 15" are suitable for a lot of different applications.
- Protocols for ABB PLCs, machinery and motion drives for Ethernet and serial connection make these control panels first choice for ABB automation solutions. The IRC5 protocol enables easy direct communication with ABB robot controllers.
- OPC UA client and server functions make them well prepared for future communication solutions.
- Integrated chromium browser usable e.g. for AC500 V3 web visualization

- Engineering by means of PB610 Panel Builder 600, part of Automation Builder, facilitates integration into automation packages and enables good scalability of the CP600 platform for various applications.

### Solid design, wide operating temperature range

The robust aluminum enclosure in attractive industrial design, providing all connectors on one side, enables installation in various environments. Wide operating temperature range from -20 up to +60 °C makes these panels suitable for even challenging environments. Landscape and portrait mounting options provide installation flexibility and various HMI presentations.

### Various options for flexible connectivity and data storage

- 2 Ethernet interfaces 10/100 Mbit with configurable bridge mode for easy connectivity with ABB automation components.
- Flexible serial connectivity with automation components without Ethernet interface.
- USB hosts for the flexible connection of accessories or data storage and easy updating.
- Memory card slot for easy data storage and updating.





—  
CP600  
control panels  
are your interface  
to the application.



#### Benefits of the new CP600 generation

- Increased performance for applications of up to 150 MB
- Improved network capabilities: 2x ETH with different physical layers (PHY)
- Extended operating temperature: -20...+60 °C
- Increased brightness: 400 cd/m<sup>2</sup>
- Black, neutral front foils suitable for most applications
- Harmonized with CP600 platform:
  - Operation system LINUX
  - Enhanced features
- Three most requested screen sizes: 7", 10.4" and 15"
- Easy replacement of former CP600 devices

# PLC Automation product family

## CP600-Pro control panels



### Outstanding HMI range designed for challenging applications

Control panels in screen sizes from 5" to 21.5" provide comprehensive HMI functions with multi-touch operation for a wide range of applications. Real glass fronts and an increased operating temperature range of  $-20\dots+60\text{ }^{\circ}\text{C}$  make them first choice even for harsh environments. The engineering tool PB610 Panel Builder 600, part of ABB Ability™ Automation Builder, ensures easy scalability on the CP600 platform.

### Multi-touch control panels for high-end applications

- The portfolio includes five screen sizes from 5" to 21.5", all widescreen, with multi-touch real glass screens for demanding high-end applications.
- The wide range of operating temperatures of  $-20\dots+60\text{ }^{\circ}\text{C}$  makes them suitable for versatile applications and first choice for demanding ones.
- Protocols for ABB PLCs, machinery and motion drives for Ethernet and serial connection make these control panels preferred option for ABB automation solutions.
- OPC UA client and server functions make them well prepared for future communication solutions.

- Engineering by means of PB610 Panel Builder 600, part of Automation Builder, facilitates integration into automation packages and enables good scalability on the CP600 platform for versatile applications.

### Real glass front and solid aluminum enclosure

CP600-Pro control panels have real glass fronts and robust aluminum enclosures in attractive industrial design, with all connectors located on one side, for installation in various even demanding environments. Landscape and portrait mounting options support installation flexibility for various HMI presentations.

### Flexible connectivity and data storage with a view to the future

- Up to 3 Ethernet networks with different physical layers for easy connectivity to ABB automation components for upcoming networking concepts.
- Flexible serial connectivity to automation components without Ethernet interface.
- USB hosts for connecting printers and accessories, data storage and updating.
- Memory card slot for easy data storage and updating.



---

The CP600-Pro control panels (7"... 15") can also be used to trigger safety actions in combination with AC500-S.

# PLC Automation product family

## PLC Automation website – online tools

The [www.abb.com/plc](http://www.abb.com/plc) website is a mine of information on our products and documentation.

**ABB** HOME • OFFERINGS • PLC AUTOMATION GLOBAL SITE

LOG IN Partners | **ABB** ABB Toolbox

You can view this page in: [EN](#) [DE](#) [IT](#) [ES](#) [PL](#) [SV](#) [FI](#) [ZH](#) [JA](#)

**PLC Automation**

ABB's automation devices deliver solutions with high performance and flexibility to be effectively deployed within diverse industries and applications including water, building infrastructure, data centers, renewable energy, machinery automation, material handling, marine and more.

**Our product offering**

- 01 Programmable Logic Controllers PLCs
- 02 Automation Builder
- 03 Control panels
- 04 Legacy products

**05 Highlights**

- New AC500-eCo V3 CPUs available soon
- AC500 PLC renewable energy automation solutions
- AC500 PLC connectivity - communication with AC500
- AC500 PLC building automation
- AC500 PLC tunnel automation
- AC500 PLC hot swap of 5500 I/O modules
- PLC Automation main catalog pdf
- PLC Automation product family movie
- CP600 2nd generation launched
- ABB safety PLC enables SIL3 protection for mine hoist systems
- ABB maximizes crane performance for Indonesia's leading port operator
- More PLC stories, articles and videos

**06 Popular links**

- Application examples selector
- Main catalog flipbook
- Industry solutions
- Documents & downloads
- Training & support
- Partner network

**07 Related products**

- Drives
- Motion control
- Robotics
- Distributed control systems
- Safety solutions
- ABB zenon

08

### Contact us

Submit your inquiry and we will contact you

[CONTACT US](#)

### Find a channel partner

Quickly find an ABB channel partner

[FIND A CHANNEL PARTNER](#)

Or contact your [ABB Contact Center](#)

**01 – Programmable Logic Controllers PLCs**

- AC500-eCo (CPUs, S500-eCo I/O modules, Accessories)
- AC500 (CPUs, Communication modules, Communication interface modules, S500 I/O modules, Accessories, Condition Monitoring CMS)
- AC500-XC (CPUs, Communication modules, Communication interface modules, S500 I/O modules, Accessories, Condition Monitoring CMS)
- AC500-S (CPUs, S500 I/O modules)

**02 – Automation Builder engineering suite**

- Download link  
[www.abb.com/automationbuilder](http://www.abb.com/automationbuilder)

**03 – Control panels**

- CP600-eCo (Devices, Software, Accessories)
- CP600 (Devices, Software, Accessories)
- CP600-Pro (Devices, Software, Accessories)

**04 – Legacy products**

- AC31 and previous series
- Control Builder
- CP400
- CP500
- DigiVis 500
- Wireless products

**05 – Highlights**

- Articles, videos, product news, success stories and more

**06 – Popular links**

- Application examples selector
- Main catalog
- Industry solutions
- Documents & Downloads
- Training & support
- Partner network

**07 – Related products**

- Drives
- Motion control
- Robotics
- Distributed control systems
- Safety solutions
- ABB zenon

**08 – Contact information for your country**

- Contact us
- Find a channel partner

Please watch our videos on our ABB PLC YouTube channel:



[www.youtube.com/user/abbplc](http://www.youtube.com/user/abbplc)





---

# ABB Ability™ Automation Builder

Integrated  
engineering suite

<b>059</b>	<b>Key features</b>
<b>060–061</b>	<b>Ordering data</b>
<b>062–063</b>	<b>Software features</b>
<b>064–065</b>	<b>Library features</b>
<b>066–067</b>	<b>Runtime license features</b>
<b>068</b>	<b>Productivity features</b>
<b>069</b>	<b>Advanced simulation support</b>

Download ABB Ability™ Automation Builder from [www.abb.com/automationbuilder](http://www.abb.com/automationbuilder)

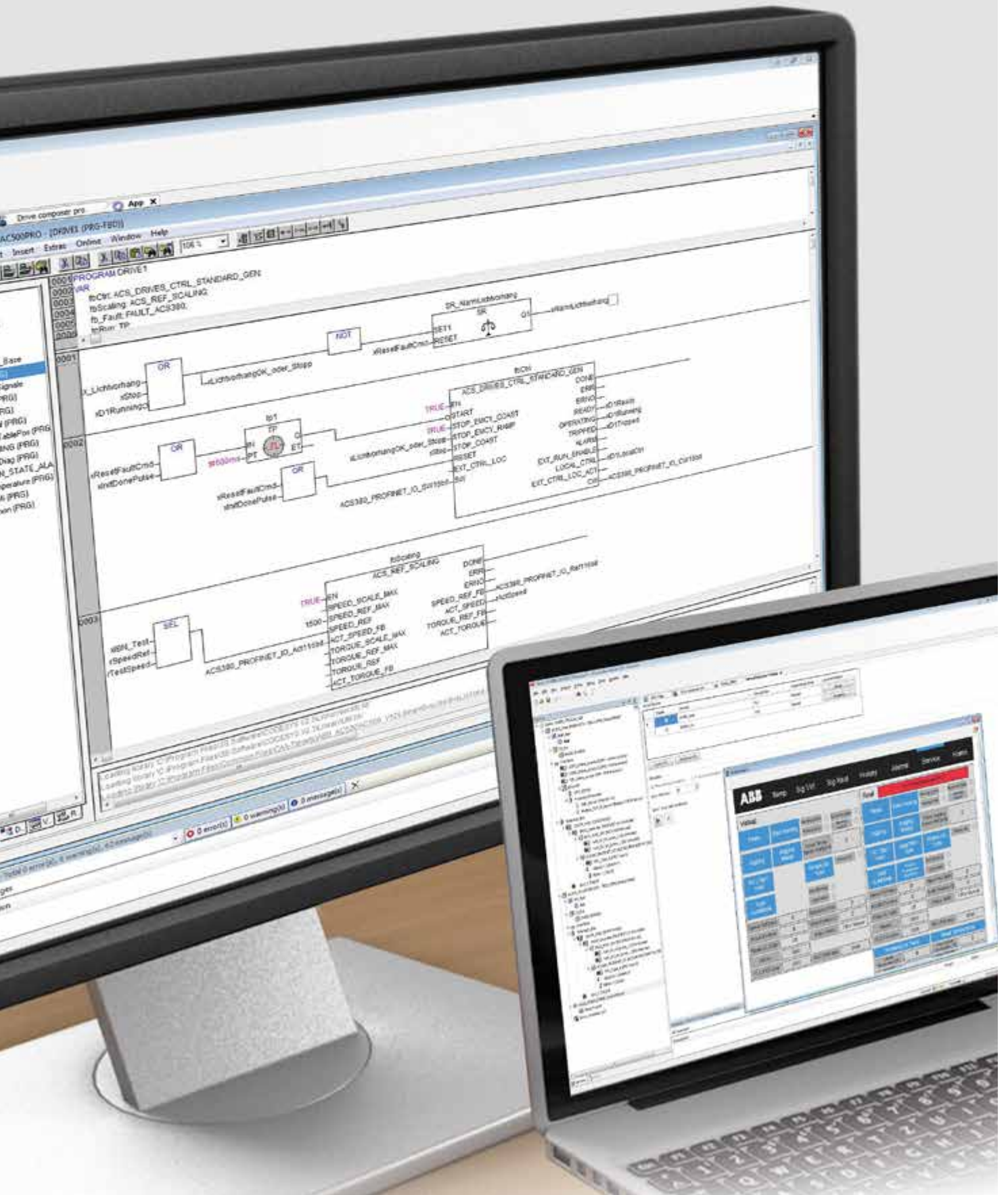

# ABB Ability™ Automation Builder

## Key features



- - Stay in control of your project: Automation Builder integrates engineering tools for PLCs, safety, drives, motion and control panels
- - Reduce risk: Manage complexity and realize connectivity easily
- - Increase efficiency: Build comprehensive solutions with integrated engineering that add value to your business
- - Combine tools: One common intuitive interface for configuring, programming, debugging and maintaining automation projects
- - Save time: Test systems effortlessly in virtual time without real hardware using advanced simulation support



## ABB Ability™ Automation Builder

### Ordering data

#### Automation Builder

- Automation Builder connects the engineering tools for PLC, safety, drives, motion and control panels. The software suite integrates products into solutions that create value for your customers, giving you greater control of your projects, reducing risk and saving time.
- Open systems win. They lead to more innovation, value and freedom of choice for your business. Automation Builder enables you to adapt the tool chain to your needs and workflows. The software is open for your specific product and communication technology to build your distinct solution.
- Automation Builder provides advanced features, further increasing engineering productivity for your automation solutions.
- Freemium license model with high flexibility in using the licenses. Licenses can be activated on PCs, USB license dongles or license servers (including borrowing of licenses for offline use).
- For details please refer to Automation Builder – Software Features.

#### Automation Builder Editions

For	Description	Type	Order code
Free 61131-3 engineering for simple PLC solutions	Automation Builder 2.x Basic (1)	-	-
Integrated Engineering for PLC, drives, motion, SCADA, panels	Automation Builder 2.x Standard (2)	DM200-TOOL	1SAS010000R0102
	Automation Builder 2.x Standard Upgrade (2)(3)	DM201-TOOL-UPGR	1SAS010001R0102
	Automation Builder 2.x Standard Network (5)	DM204-TOOL-NW	1SAS010004R0102
Integrated Engineering for PLC, drives, motion, SCADA, panels and features for engineering productivity and collaboration	Automation Builder 2.x Premium (5)	DM202-PREM	1SAS010002R0102
	Automation Builder 2.x Premium Upgrade (4)(5)	DM203-PREM-UPGR	1SAS010003R0102

#### Automation Builder add-ons

Functional safety engineering	AC500-S Safety PLC programming	DM220-FSE (2) DM221-FSE-NW (5)	1SAS010020R0102 1SAS010021R0102
Collaborative engineering support	Professional Version Control with Subversion for Automation Builder 2.x	DM207-PVC (2) DM214-PVC-NW (5)	1SAS010007R0102 1SAS010014R0102
Static code analysis	Professional Static Analysis for Automation Builder 2.x	DM210-PSA (2) DM217-PSA-NW (5)	1SAS010010R0102 1SAS010017R0102
Optimization of runtime performance	Professional Profiler for Automation Builder 2.x (6)	DM211-PPR (2) DM218-PPR-NW (5)	1SAS010011R0102 1SAS010018R0102
Advanced simulation support	Advanced simulation capabilities for Automation Builder 2.x (7)	DM250-VCP (2) DM251-VCP-NW (5)	1SAS010050R0102 1SAS010051R0102

#### Accessories

Automation Builder licensing based on a USB Key	USB Key for Automation Builder without license (8)	DM-KEY	1SAP193600R0001
---	--	--------	-----------------

All Automation Builder PC software licenses can be installed either on engineering PCs or on USB dongles. Network licenses can also be installed on a license server. The licenses can be transferred between computers or dongles unlimited times.

(1) Free license

(2) Single user license - bound to PC or DM-KEY (USB Key)

(3) Purchase this option to upgrade Automation Builder 1.x Standard to Automation Builder 2.x Standard

(4) Purchase this option to upgrade Automation Builder 1.x Premium to Automation Builder 2.x Premium. Edition upgrade licenses from Automation Builder 2.x Standard to Automation Builder 2.x Premium are available on demand.

(5) Network license for shared usage within a local area network or for usage on Windows Server operating systems. Per license one user can use the license at the same time. Network licenses that can be borrowed for offline use are available on request.

(6) In preparation

(7) Expert function - only available on request

(8) Does not contain license. Automation Builder license must be purchased separately. Can carry an arbitrary number of licenses.



Automation Builder



## ABB Ability™ Automation Builder

### Ordering data

#### AC500 Library Licenses

For	Description	Type	Order code
all AC500 V2 CPUs	Solar library	PS562-SOLAR	1SAP195000R0101
all AC500 V2 CPUs	Water library	PS563-WATER	1SAS03000R0101
all AC500 V2 CPUs	Motion Control library, Extended	PS552-MC-E	1SAP192100R0102
all AC500 V2 CPUs	Temperature control library	PS564-TEMPCTRL	1SAS030010R0101
all AC500 V2 CPUs	BACnet library B-ASC profile	PS565-BACnet-ASC	1SAP195500R0101

Delivery includes a single user license, which can be used for creating applications for an unlimited number of CPUs. All library licenses can be installed on engineering PCs, on USB dongles or on Windows Server operating systems. The licenses can be transferred between computers or dongles unlimited times.

#### AC500 Runtime Licenses

For	Description	Type	Order code
all AC500 CPUs	Modbus TCP HA runtime license	PS5601-HA-MTCP	1SAP195400R0101
all AC500 V3 CPUs	IEC 61850 protocol runtime license (2)	PS5602-61850	1SAP195600R0101
all AC500 V3 CPUs	KNX IP protocol runtime license (2)	PS5604-KNX	1SAP195800R0101
all AC500 V3 CPUs	BACnet protocol B-BC runtime license (2)	PS5607-BACnet-BC	1SAP195550R0101
all AC500 V3 CPUs	Motion control library runtime license	PS5611-MC	1SAP192150R0101
AC500 V3/AC500-eCo V3	Ethernet/IP scanner runtime license for AC500 V3 (1) (for PM5032, PM5052, PM5072 and PM56xx)	PS5613-EIP-S	1SAP196101R0101
AC500-eCo V3	Ethernet/IP scanner runtime license for AC500-eCo V3 (1) (for PM5032, PM5052 and PM5072)	PS5613-EIP-S-e	1SAP196103R0101
AC500 V3/AC500-eCo V3	Ethernet/IP adapter runtime license for AC500 V3 (1) (for PM5032, PM5052, PM5072 and PM56xx)	PS5613-EIP-A	1SAP196100R0101
AC500-eCo V3	Ethernet/IP adapter runtime license for AC500-eCo V3 (1) (for PM5032, PM5052 and PM5072)	PS5613-EIP-A-e	1SAP196102R0101

For using runtime licensed features one license per CPU is required. The license has to be installed on the AC500 V3 CPU either by connecting it to Automation Builder or via Memory card that has been prepared by Automation Builder for license activation.

The licenses can be transferred between AC500 V3 CPUs unlimited times.

(1) In preparation

(2) Also available for AC500-eCo V3 PM5072

#### Further application libraries and examples:

Please check and download further libraries and examples from: [www.abb.com/plc](http://www.abb.com/plc)

Use English language setting, then click on “Application Examples”.

Application Examples explain functionality by using e.g. standard Automation Builder libraries and functions in simple examples. They are tested in the described example configuration and functionality only, they come with documentation and are free of charge.

Applications Examples help to minimize valuable programming and testing time for specific applications.



AC500 libraries

# ABB Ability™ Automation Builder

## Software features

Automation Builder		Basic	Standard	Premium
Features and target hardware		Basic system engineering FREE	Integrated system engineering	Productivity and collaboration
Productive engineering	Integrated engineering for PLCs, safety, robots, motion, drives and control panels	○	●	●
	Integrated tool suite installation and maintenance (online and offline)	●	●	●
	Project handling including project archive and backup features	●	●	●
	Project lifecycle support (version profiles and project migration)	●	●	●
	Native language support in EN, DE, ES, FR, CN	●	●	●
	Support of standardization and re-use by flexible configurations of machine variants and advanced I/O device handling	●	●	●
	Support of re-use by cross project and cross Automation Builder instance copy&paste	●	●	●
	ECAD roundtrip engineering - AC500 and EPLAN / Zuken E3			●
	ECAD roundtrip engineering for 3rd party devices - PLC and EPLAN / Zuken E3			●
	Bulk data import/export with change control to any tool via CSV (also via copy&paste)			●
	Bulk data import/export of device and I/O lists and IEC 60870-5-104			●
	Change management support by project compare			●
	Automation of engineering (execution of Python scripts)			●
Virtual system testing based on Virtual Commissioning Technology		○	○	
Collaborative engineering support by Professional Version Control with Subversion			○	
PLC engineering (AC500 V2)	<b>For: AC500-eCo, AC500 V2, AC500-XC, AC500-S Safety, AC500 local I/O modules, AC500 extension modules</b>			
	PLC application programming (IL, LD, FBD, SFC, ST) plus CFC	●	●	●
	PLC firmware update, download and online change to single or several PLCs	●	●	●
	PLC simulation, diagnosis and debugging	●	●	●
	Integrated firmware identification and update (PM and CM devices)	●	●	●
	Configuration of communication protocols for TCP/IP, Modbus, CS31, IEC 60870-5-104	●	●	●
	Configuration of communication protocols for PROFINET, EtherCAT, PROFIBUS DP, CAN (all via coupler)		●	●
	Condition Monitoring CMS: configuration, libraries for CMS control and wave file handling		●	●
	C/ C++ application programming (GNU compiler)			●
	Advanced simulation support including virtual PLCs		○	○
PLC engineering (AC500 V3)	<b>For: AC500 V3 and supported AC500 local I/O modules and AC500 extension modules</b>			
	PLC application programming (LD, FBD, SFC, ST) plus CFC	●	●	●
	PLC firmware update, download and online change to single PLC	●	●	●
	PLC diagnosis and debugging	●	●	●
	Integrated firmware identification and update (PM and CM devices)	●	●	●
	Configuration of communication protocols for TCP/IP, Modbus TCP, Modbus RTU, CAN	●	●	●
	Configuration of onboard communication protocols for IEC 60870-5-104, IEC 61850, BACnet, KNX		●	●
	Configuration of communication protocols for PROFINET, EtherCAT, CAN (all via coupler)		●	●
	Static code analysis		○	○
	Advanced simulation support including virtual PLCs (in preparation)		○	○
Safety PLC engineering (integrated solutions)	<b>For: AC500-S Safety CPU, Safety I/Os and PROFIsafe devices</b>			
	Safety PLC application programming (LD, FBD, ST)		○	○
	Fieldbus protocol engineering for PROFIsafe		○	○
SCADA engineering	<b>For: ABB zenon</b>			
	Integrated SCADA and PLC engineering with ABB zenon Editor		○	○

# ABB Ability™ Automation Builder

## Software features

Automation Builder		Basic	Standard	Premium
Features and target hardware		Basic system engineering FREE	Integrated system engineering	Productivity and collaboration
<b>Control Panel engineering</b>	<b>For: CP600, CP600-Pro, CP600-eCo, CP600-WEB, PB610-R</b>			
	CP600 , CP600 2 <sup>nd</sup> generation and CP600-Pro panel configuration with PB610 Panel Builder 600	○	●	●
	CP600-eCo panel configuration with PB610 Panel Builder 600	●	●	●
	PLC tag data import	●	●	●
	Control Panel simulation	●	●	●
<b>Drive engineering</b>	<b>For: ACS355, ACS380, ACS480, ACS550, ACS580, ACS850, ACQ810, ACS880, DCS880, ACSM1</b>			
	Drive management, configuration and diagnosis with common process data editor (Drive - PLC)		●	●
	Drive engineering in Drive composer pro	○	●	●
<b>Motion engineering</b>	<b>For: MicroFlex e150, Motiflex e180, Motiflex e190</b>			
	Motion application engineering with Mint WorkBench	●	●	●
	PLC tag data import	●	●	●
<b>Modbus TCP engineering</b>	<b>For: CI521-MODTCP, CI522-MODTCP</b>			
	Configuration and diagnosis of unbundled Modbus TCP CI (communication interface) devices	●	●	●
<b>Solution engineering</b>	Drive library (PS553-Drives, PS5605-Drives)	●	●	●
	MQTT and JSON libraries	●	●	●
	Motion Control Library V2: PS552-MC-E; V3: PS5611-MC (1)	○	○	○
	Solar library V2: S562-SOLAR	○	○	○
	Water library V2: PS563-WATER	○	○	○
	Temperature Control library V2: PS564-TEMPCTRL	○	○	○
	BACnet - ASC library V2: PS565-BACnet-ASC	○	○	○
	BACnet - BC protocol V3: PS5607-BACnet-BC, (incl. ASC) (1)		○	○
	AC500 High Availability V2: HA-CS31 library		●	●
	AC500 High Availability HA-Modbus TCP library V2/V3: PS5601-HA-MTCP (1)		○	○
	KNX-protocol V3: PS5604-KNX (1)		○	○
	IEC 61850 for AC500 V3: PS5602-61850 (1)		○	○
	PackML library (*)		●	●
	FTP client library (PS554) (*)		●	●
	Signal Processing Package (*)		●	●
	Pumping library (PS571) (*)		●	●
HVAC library (*)		●	●	
Process control objects (PCO) library (*)	●	●	●	
Ethernet/IP (PS5613-ETHIP) (1)		●	●	
<b>Further features</b>	PLC Multidownload tool for large installations	●	●	●
	OPC server and clients, service tool, PLC gateway, IP configuration and visualization	●	●	●
<b>Operating systems</b>	Windows 10 (32/64 Bit) Professional / Enterprise, Windows Server 2012 R2 64 Bit, Windows Server 2019	●	●	●
<b>PC requirements</b>	Minimum: 1 GHz, 4 GB RAM, 5-18 GB free disk space	●	●	●

● included

○ optional (additional license required) as integrated tool / feature / library

○ optional (additional license required) as standalone tool / feature - not integrated in Automation Builder

(1) additional runtime license per PLC required

(\*) Technology Preview: Technology Previews are non-final versions of our product and should not be taken as a measure of the fit, finish, capability, and overall quality of the product.

# ABB Ability™ Automation Builder

## Library features

02

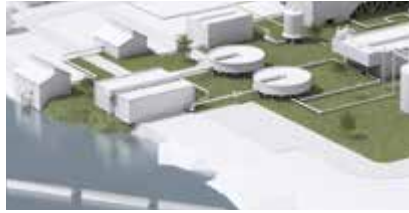

### PS562-SOLAR

#### Solar tracker solution library

Library for solar tracking applications enabling fast engineering, especially together with ABB's drives and motors

Covers different tracker configurations and different algorithms for accuracy needs

- Control of trackers in parabolic trough, power tower, PV and CPV applications.

Complete library package for different tracking use cases, plug and play:  
Example program with detailed explanations and visualizations

- Control of the tracker adaptable to different needs and conditions, to achieve maximum efficiency of installation
- Exact positioning of different axes with the following accuracies:
  - NOAA algorithm 0.03 Grad
  - NREL algorithm 0.0003 Grad.
- Input / sensor adaptation
- Communication
- Different actuators / drives control
- All needed modes for simple commissioning and manual operation:
  - Fast and simple calibration of the trackers, offering manual repositioning and fine tuning
  - Safety positions
  - Back tracking.

### PS563-WATER

#### Water solution library

Library supporting the most common functions in many water applications

- Flexible data logging options:
- Especially suited for remote communication like GSM/GPRS
  - Timestamp in logging
  - Integrated variants for simple use with IEC 60870-5-104
  - Logging to files: storage capacity only dependent on memory availability
  - Flexible log conditions (cyclic, event or tolerance based).

Support for pumping station functions with different operation modes

- Standard multidrive functions (PLC based)
- Advanced functionality together with ABB ACS and ACQ810 drives
- Detailed diagnosis
- Energy efficiency functions
- Multidrive functions
- Flow estimation.

Control Panel CP600 support for ACQ810: Fast and simple configuration for pumping stations with reduced programming effort via pre-built visualization screen templates.

Application examples for fast engineering and startup.

### PS564-TEMPCTRL

#### Temperature control library

Library packet for advanced temperature control applications

Includes extended, flexible PID functionality with Auto-tune for temperature control

- Enhanced response time and reduced overshoots and oscillations
- Option to optimize control for very different heating and cooling characteristics.
- Enhanced tolerance to thermocouple input noise
- Normal and standby- setpoints
- Multi-level temperature monitoring and alarms provides flexible operation and protection for machine and process
- Logging enables complete overview of the actual situation and past behavior
- Configurable output timing, synchronization for peak load shaving in multi-zone setups
- Simulation blocks enable off-line setup and pre-test of a new project
- Group-programming

Example projects, including adaptable HMI project for CP600 family, well suited for multi zone and grouped temperature control e.g. in Extrusion:

- Easy to use operator interface
- Provides quick access to setup, monitoring and tuning screens for multiple zones
- Easily extendable to a large number of zones
- Zones: heat-, cool-only or heat-and-cool

#### License Package (Software is part of Automation Builder)

All AC500 V2 CPUs  
NOAA: PM554-XX and above  
NREL: PM573-ETH and above.

All AC500 V2 CPUs  
Logging: PM573 and above.

All AC500 V2 CPUs.

# ABB Ability™ Automation Builder

## Library features



### PS552-MC-E

#### Motion control library

Library enabling fast and standardized engineering according to PLCopen standard when using ABB's AC500 PLC for motion control, especially together with ABB's motion control Drives.

Covers different motion control options for single and multi-axes motion control applications:

- Drive-Based and PLC-Based motion
- In PLC based interpolation, the position control loop could be closed in the PLC or drive (with synchronized network)
- Single axis, multi-axes and coordinated motion
- Defined Jerk limitation by polynomial interpolation
- Spline interpolation or polynomial interpolation for cam curves, position velocity or acceleration profiles available
- Possible to switch over between different movements and cam curves on the fly
- latch functionality by utilizing fast drive inputs for ACS350, ACS800, ACSM1
- Drive based motion: commands from PLC, drives perform interpolation and control loop
- Supports the new Pulse Train Output module FM562.

PLCopen functions:

- Administrative Function Blocks
- Single axis Function Blocks
- Multi-axes Function Blocks
- Homing Function Blocks
- Coordinated Motion Function Blocks
- Additional ABB specific Function Blocks for further simplification.

License Package (Software is part of Automation Builder)

All AC500 V2 CPUs (options and no. of blocks/ functions and performance will depend on CPU size and memory).

### PS565-BACnet-ASC

#### BACnet communication library

This library enables AC500 PLCs to connect OEM or infrastructure applications to BMS (Building Management Systems) or other controllers.

The PS565-BACnet-ASC library enables AC500 to serve as BACnet server device, complying with the B-ASC Device Profile and interfacing control requirements, and acting as hardwired or Modbus-to-BACnet gateway.

It supports BACnet IP (Ethernet) and BACnet MS/TP (serial) networks. The scalable AC500 platform is compatible with the BACnet library starting from eCo PM5x6 with larger memory (~ 300 objects) up to PM595 (more than 5000 objects).

The very transparent, object-oriented publish and subscribe approach of BACnet allows efficient and well-documented engineering and collaboration of many different parties in large infrastructure projects.

Highlights

- Easy-to-use BACnet communication directly in the CPU
- No coupler or gateways required
- Cost-efficient particularly for OEMs and projects
- Interfacing other non-BACnet devices to BMS.

BACnet for AC500 is BTL approved and certified.

### PS573-PCO

#### Process control objects library

Facilitates the use of AC500 as controller in DCS solutions by providing function blocks for easy integration into the process visualization.

Twelve function blocks are available which cover the following functionalities:

- Digital and analog setpoints
- Analog measurement with threshold alarm functions
- Valve control
- Motor control with or without variable speed drives
- Proportional integral controller

The function blocks have an internal interface to the DCS system. Status and control are exchanged with the DCS system via OPC DA. For ABB Ability™ System 800xA an optional object library is available which contains symbols and faceplates that match the function blocks.

(No license required)

All AC500 V2 CPUs have an onboard Ethernet interface (number of function blocks and performance will depend on the CPU size and memory).



## ABB Ability™ Automation Builder

### Runtime license features



#### PS5601-HA-MTCP

##### High availability library using Ethernet (Modbus TCP)

Runtime license per CPU to download library into the CPU.

Same philosophy as proven serial/CS31 based library.

Enables hot-standby redundancy and bumpless transfer with standard AC500 CPUs.

Supports 3 redundancy levels:

- CPU
- I/O communication
- SCADA communication

Library package containing libraries based on Modbus TCP for field communication and using CI52x communication interface modules as I/O clusters with redundant connection.

Ethernet redundancy based on externally managed switches: Ethernet network can be independent of the redundancy mechanism used.

- Daisy chain in ring configuration of CI52x with MRP as redundancy protocol
- Fast reaction and switchover nearly independent of the number of clusters
- Possibility of integrating other devices e.g. ABB drives into the redundancy scheme.

Scalable redundancy, where CPUs can also be placed far away from each other (...kilometers if fiber-optic networks are used).

Includes the AC500 Bulk Data Manager as a tool for efficient configuration and cluster engineering.

- Configuration and export of projects, clusters, modules/parameters, signal names, visualization ("code generation")

Application examples for fast engineering and startup.

#### PS5602-61850

##### IEC 61850 MMS server and GOOSE communication

This runtime license enables the AC500 V3 PLC to connect to substation type equipment (IEDs) or act as IED.

The protocol library and configuration tool are part of Automation Builder. The runtime license is needed for download.

61850 server edition 1 allows:

- sending MMS messages to ensure a safe data communication – no real time support
- publishing and subscribing to GOOSE messages for high priority peer-to-peer data exchange between different servers to ensure a data transmission with minimal delay
- up to 5 client connections per server
- up to 50 entries per dataset
- up to 20 datasets

Automation Builder used as IED configuration tool

- Import / export of SCL files formats
- ICD – IED capability description file
- SCD – substation configuration description file
- CID – configured IED description file

Basic display options

Highlights

- Wide set of Logical Nodes provided
- Further Logical Nodes can be defined
- Implementation can be programmed freely in IEC 61131.

The IEC 61850 protocol of the AC500 PLC is TÜV certified.

#### PS5604-KNX

##### KNX IP communication

This runtime license enables the AC500 V3 PLC to connect to KNX IP.

The protocol and configuration options are part of Automation Builder and FW. The runtime license is needed for download.

Support of

- Up to 1000 group objects
- Programming the physical address via ETS
- Downloading the KNX group address linking via ETS

Highlights

- Easy to use KNX communication directly in CPU due to tight ETS5 and Automation Builder integration via DCA
- No coupler or gateways needed
- Cost-efficient especially for OEMs and projects
- Enables holistic building automation solutions.

Runtime license (Software is part of Automation Builder)

All AC500 V2 and V3 CPUs

All AC500 V3 CPUs

All AC500 V3 CPUs

## ABB Ability™ Automation Builder

### Runtime license features



#### PS5607-BACnet-BC

##### BACnet communication

This runtime license enables the BACnet protocol on AC500 PLCs to connect OEM or infrastructure applications to BMS (Building Management Systems) or other controllers.

The PS5607-BACnet-BC license enables AC500 to act as BACnet server and client device, complying with the B-BC device profile.

It supports the use of BACnet IP (Ethernet) and BACnet MS/TP (serial) (1) networks to be used with the scalable AC500 platform V3 CPUs.

The very transparent, object-oriented publish and subscribe approach of BACnet allows efficient and well-documented engineering and collaboration of many different parties in large infrastructure projects.

##### Highlights

- Comfortable configuration and editing in the Automation Builder with library support
- Easy-to-use BACnet communication directly in the CPU
- No coupler or gateways required
- Cost-efficient, particularly for OEMs and projects
- Interfacing other non-BACnet devices to BMS.

BACnet for AC500 is BTL approved and certified.

#### PS5611-MC

##### Motion Control library

Runtime license enabling fast and standardized engineering according to PLCopen standard when using ABB's AC500 V3 PLC for motion control.

Covers different motion control options for single and multi-axes motion control applications:

- PLC-based interpolation, the position control loop can be closed in the PLC or drive (with synchronized network)
- Single axis and multi-axes motion
- Defined Jerk limitation by polynomial interpolation
- Spline interpolation or polynomial interpolation for cam curves, position, velocity or acceleration profiles available
- Possibility for switching over between different movements and cam curves on the fly
- Latch functionality with drive support
- Virtual axes possible
- Same PLCopen blocks to support different drives, communication networks and control principles
- Application-specific interpolation algorithms can be integrated
- Supports AC500-eCo V3 with Pulse Train Output.

##### PLCopen functions:

- Administrative Function Blocks
- Single axis Function Blocks
- Multi-axes Function Blocks
- Homing Function Blocks
- Additional ABB-specific Function Blocks for further simplification.

Runtime license (Software is part of Automation Builder)

All AC500 V3 CPUs

All AC500 V3 CPUs

(1) MS/TP in preparation

# ABB Ability™ Automation Builder

## Productivity features

### Object-oriented programming of AC500 V3 CPUs

All essential features of standard object-oriented programming are included in Automation Builder's object-oriented programming:

- Better structured program code with “separation of concerns” and information hiding
- Flexible extensibility by new types of objects (e.g. software representations of new types of drives)
- Reuse of code for defining specialized sub-classes (inheritance), reuse of code operating on different implementations of an interface (polymorphism)
- New optimized editors for IEC programming languages
- Continuous Function Chart (CFC) with auto routing of connections between POU's, unrestricted definition and display of the execution order
- Structured Text (ST) with Support for quick editing with extensive support, such as intelligence, grouping, collapsible tree structure, and indented brackets

### HMI integration

Synchronization of connection settings and access to tags on the AC500 PLC.

### Drive integration

Seamless integration of ABB Drives connected to AC500 PLCs:

- Common configuration of cyclic data exchange
- Access to the drive via the AC500 PLC - no need for point-to-point connections
- Upload, download and offline editing of drive parameters

### Integrated configuration of AC500 software features

All required AC500 software features can be selected and configured by Automation Builder, e.g.

- KNX gateway for connecting to building automation devices
- BACnet B-BC object engineering
- IEC 60870 protocol for data exchange with substations
- Time synchronization via SNTP
- Shared variables with other AC500 PLCs

### Professional version control – management of the application project

Professional Version Control is an integrated link to the version control system Subversion (SVN). End users can use this tool to manage independently both the complete IEC 61131-3 project version, as well as the individual application objects. End users benefit from automated management of the source code when developing a project in various teams or over a long period of time.

### Professional static analysis

With static code analysis it is possible to check the source code of AC500 applications based on pre-defined rules and naming conventions. Additional information on potential development problems is revealed and errors can be detected and eliminated before the application will be tested on the PLC. Static code analysis implements more than 100 pre-defined and partly configurable rules.



# ABB Ability™ Automation Builder

## Advanced simulation support

Automation Builder 2.0 has introduced advanced simulation support which allows machine builders and system integrators to simulate and automate all kinds of applications with minimum effort. This gives seamless testing of the complete system at an early stage, even when all the necessary hardware is not yet ready. Even complex systems can be built up quickly and efficiently, ensuring smooth interaction of all the components.

Advanced simulation support lets you build simulation models from virtual devices and manage the virtual time and signal exchange between the virtual devices. Furthermore it provides interfaces to control and manipulate the simulation e.g. via OPC UA, OPC DA or via UDP communication.

Virtual devices emulate real hardware. They function as real hardware, provide signals (onboard, local, fieldbus/remote IOs) and variables. Virtual time lets you control the execution of the simulation. Speed up, slow down or freeze the execution for testing and debugging.

By connecting to external simulation tools (e.g. RobotStudio), additional components can be included to these models. This allows to simulate the real system including physical inputs or actuators. The flexible architecture of the advanced simulation support allows to extend your simulation to more advanced aspects, e.g. the dynamic system behavior.









---

# AC500-eCo

## Entry level PLC solutions

<b>073</b>	<b>Key features</b>
<b>074–081</b>	<b>Ordering data</b>
<b>082–096</b>	<b>Technical data</b>
<b>097–098</b>	<b>System data</b>

MC

**ABB**

PM5072

TA5130-KNXPB

PWR

ERR

PRG

RUN

COM  
0..11

10

11

12

13

14

15

16

17

18

19

I10

I11

00

1

2

3

4

5

6

7

8

9

10

11

12

13

TA5120-2AI-U

IO+

ETH1

ETH2

30

# AC500-eCo

## Key features



- High performance variant with large memory available
- Simple variant for entry level application

- Up to 10 I/O modules connected to the V2 and V3 Standard and Pro CPU
- Compatible with all standard I/O modules (S500 and S500-eCo)
- Digital I/O module with configurable I/O available

- Up to three different types of terminal blocks available (V2/V3)
- Large number of integrated onboard I/O
- Fast I/O for motion application and axis control
- Onboard I/O extension using option boards for digital or analog channels
- AC versions with integrated power supply (V2), only DC (V3)

- Comprehensive communication and options:
  - Up to two Ethernet interfaces for communication and web server for user defined visualization
  - Up to three serial ports for decentralized I/O and communication using option boards
  - New Ethernet-based communication available

## AC500-eCo

### Ordering data

#### AC500-eCo CPUs

- 1 RS485 serial interface (2nd is optional)
- Can be centrally extended with up to 10 I/O modules (standard S500 and/or S500-eCo modules can be mixed)
- Optional memory card adapter for data storage and program backup
- Variants with integrated Ethernet (Ethernet includes web server)
- Minimum cycle time per instruction: Bit 0.08  $\mu$ s, Word 0.1  $\mu$ s, Float-point 1.2  $\mu$ s.

Program memory kB	Onboard I/Os DI/DO/AI/AO	Relay /Transistor outputs	Integrated communication	Power supply	Type	Order code	Price	Weight (1 pce) kg
<b>PM554: digital I/Os</b>								
128	8 / 6 / - / -	Transistor	-	24 V DC	PM554-TP	1SAP120600R0001		0.300
128	8 / 6 / - / -	Relay	-	24 V DC	PM554-RP	1SAP120700R0001		0.400
128	8 / 6 / - / -	Relay	-	100-240 V AC	PM554-RP-AC	1SAP120800R0001		0.400
128	8 / 6 / - / -	Transistor	Ethernet	24 V DC	PM554-TP-ETH	1SAP120600R0071		0.400
<b>PM556: digital I/Os, 512 kB program memory</b>								
512	8 / 6 / - / -	Transistor	Ethernet	24 V DC	PM556-TP-ETH	1SAP121200R0071		0.400
<b>PM564: digital and analog I/Os (1)</b>								
128	6 / 6 / 2 / 1	Transistor	-	24 V DC	PM564-TP	1SAP120900R0001		0.300
128	6 / 6 / 2 / 1	Relay	-	24 V DC	PM564-RP	1SAP121000R0001		0.400
128	6 / 6 / 2 / 1	Relay	-	100-240 V AC	PM564-RP-AC	1SAP121100R0001		0.400
128	6 / 6 / 2 / 1	Transistor	Ethernet	24 V DC	PM564-TP-ETH	1SAP120900R0071		0.300
128	6 / 6 / 2 / 1	Relay	Ethernet	24 V DC	PM564-RP-ETH	1SAP121000R0071		0.400
128	6 / 6 / 2 / 1	Relay	Ethernet	100-240 V AC	PM564-RP-ETH-AC	1SAP121100R0071		0.400
<b>PM566: digital and analog I/Os, 512 kB program memory (1)</b>								
512	6 / 6 / 2 / 1	Transistor	Ethernet	24 V DC	PM566-TP-ETH	1SAP121500R0071		0.400

Terminal blocks (9 and 11 poles) are necessary for each AC500-eCo I/O. The terminal blocks must be ordered separately.

(1) All analog inputs on PM564 and PM566 can be configured as digital inputs.



PM554  
AC500-eCo CPU  
with Ethernet



PM564  
AC500-eCo CPU  
without Ethernet

## AC500-eCo

### Ordering data

#### Accessories

Description	Type	Order code	Price	Weight (1 pce) kg
Memory card 2 GB needs the MC503 option	MC502 (2)	1SAP180100R0001		0.020
Micro memory card 8 GB with adapter needs the MC503 option (4)	MC5102 (3)(4)	1SAP180100R0002		0.020
Memory card adapter board	MC503	1TNE968901R0100		0.010
Programming cable USB => RS485 Sub-D, 3 m	TK503	1TNE968901R1100		0.400
Programming cable USB => RS485 Terminal block, 3 m	TK504	1TNE968901R2100		0.400
RS485 isolator, Sub-D 9 poles / Terminal 5 poles for COM1	TK506	1SAP186100R0001		0.080
Real time clock option board, battery CR2032 not included	TA561-RTC (1)	1SAP181400R0001		0.007
RS485 serial adapter COM2, pluggable screw terminal block included	TA562-RS	1TNE968901R4300		0.007
Combined real time clock option with RS485 serial adapter COM2, pluggable screw terminal block, included	TA562-RS-RTC (1)	1SAP181500R0001		0.012
Screw mounting accessory for AC500-eCo CPU and S500-eCo I/O modules (100 pieces per pack)	TA566	1TNE968901R3107		0.450
RS485 isolated serial adapter COM2, pluggable screw terminal block included	TA569-RS-ISO	1SAP186400R0001		0.030
Set of accessories: 6 x plastic cover for option slot, 6 x 5 pole terminal block, 6 x 5 pole screw terminal block for COM2 serial interface.	TA570	1TNE968901R3203		0.090
Digital input simulator for onboard I/O of CPU, 6 x switch, 24 V DC	TA571-SIM	1TNE968903R0203		0.040

(1) Standard battery CR 2032 has to be purchased separately.

(2) Not suitable for new project, product is transferred to life cycle phase classic in 2021, use MC5102 as replacement

(3) In preparation

(4) When used with AC500-eCo V2 CPU, the usable capacity is limited to 4 GB. For temporary use, e.g. firmware- or project-download. Not to be used during vibration or shock.



TK506



TA561-RTC

TA562-RS  
TA569-RS-ISO

TA562-RS-RTC



TA570

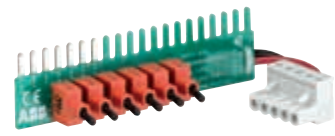

TA571-SIM



## AC500-eCo

### Ordering data

#### AC500-eCo V3 CPUs

- Three performance classes CPU (Basic, Standard and Pro) with large memory
- From low-entry and cost-sensitive to large and complex applications
- One or two independent Ethernet interfaces with integrated switch functionality
- Up to three RS232 or RS485 serial interfaces using option boards
- Micro memory card slot for data storage and program backup
- Real time clock for Standard and Pro CPU, optional for Basic
- Web server functionality with HTML5 Web visualization for Standard and Pro CPU
- Minimum cycle time per instruction: Bit 0.02  $\mu$ s, Word 0.02  $\mu$ s, Floating point 0,6  $\mu$ s.
- High amount of onboard I/Os with relay or transistor outputs
- Onboard high-speed I/Os with motion control function for up to 4 axis PTO
- Extendable with up to three digital or analog option boards
- Standard and Pro version can be locally extended with up to 10 I/O modules (S500 and/or S500-eCo modules can be mixed)
- 24 V DC power supply.

Total user program memory	Onboard I/Os	Relay / Transistor outputs	Integrated communication	Option board slots for extension	Power supply	Type	Order code	Price	Weight (1 pce)
kB	DI/DO/DC								kg
<b>Basic CPU PM5012-x-ETH: 1MB CPU, Ethernet interface, onboard digital I/O, not extendable, 1 slot for option board</b>									
1 MB (thereof 256 kB Program code and Data) (3)	6 / 4 / -	Transistor	1x Ethernet	1	24 V DC	PM5012-T-ETH	1SAP122600R0072		0.300
	6 / 4 / -	Relay	1x Ethernet	1	24 V DC	PM5012-R-ETH	1SAP122700R0072		0.400
<b>Standard CPU PM5032-x-ETH: 2MB CPU, Ethernet interface, RTC and micro memory card, onboard digital I/O, extendable, 2 slots for option board</b>									
2 MB (thereof 512 kB Program code and Data + 1.5 MB Web max.) (3)	12 / 8 / 2	Transistor	1x Ethernet	2	24 V DC	PM5032-T-ETH	1SAP123400R0072		0.400
	12 / 6 / 2	Relay	1x Ethernet	2	24 V DC	PM5032-R-ETH	1SAP123500R0072		0.400
<b>Standard CPU PM5052-x-ETH: 4MB CPU, Ethernet interface, RTC and micro memory card, onboard digital I/O, extendable, 3 slots for option board</b>									
4 MB (thereof 768 kB Program code and Data + about 3 MB Web max.) (3)	12 / 8 / 2	Transistor	1x Ethernet	3	24 V DC	PM5052-T-ETH	1SAP124000R0072		0.400
	12 / 6 / 2	Relay	1x Ethernet	3	24 V DC	PM5052-R-ETH	1SAP124100R0072		0.400
<b>Pro CPU PM5072-x-ETH: 8MB CPU with two Ethernet interface, RTC and micro memory card, onboard digital I/O, extendable, 3 slots for option board</b>									
8 MB (thereof 1 MB Program code and Data + 7 MB Web max.) (3)	12 / 8 / 2	Transistor	2x independent Ethernet with switch	3	24 V DC	PM5072-T-2ETH	1SAP124500R0073		0.400
8 MB (thereof 1 MB Program code and Data + 7 MB Web max.) extended wide temperature (3)	12 / 8 / 2	Transistor	2x independent Ethernet with switch	3	24 V DC	PM5072-T-2ETHW (1)	1SAP124400R0073 (2)		0.400

Terminal block sets are necessary for each AC500-eCo V3. The terminal blocks must be ordered separately.

(1) Wide extended temperature -20 °C ... +70 °C.

(2) On demand.

(3) Memory size of V2 versus V3 CPUs is not comparable. Projects have a different and separate User Program code and Data memory calculation in Automation Builder 2.4.0 version or later. System, configuration and web server parts are not counted anymore. This results in typically about 50 % lower memory usage compared to V2, and even lower memory usage compared to V3 projects compiled in Automation Builder 2.3.0 or before.



PM5012-x-ETH  
Basic CPU



PM5032-x-ETH  
Standard CPU



PM5052-x-ETH  
Standard CPU



PM5072-T-2ETH(W)  
Pro CPU

## AC500-eCo

### Ordering data

#### Terminal block sets for AC500-eCo V3 CPU

Content of the sets	Connection type	Cable entry	Type	Order code	Price	Weight (1 set) kg
<b>For Basic CPU</b>						
1x 3 poles for power supply, 1x 13 poles I/O terminal blocks	Screw	5 mm pitch	Side	TA5211-TSCL-B	1SAP187400R0001	0.150
1x 3 poles for power supply, 1x 13 poles I/O terminal blocks	Spring	5 mm pitch	Front	TA5211-TSPF-B	1SAP187400R0002	0.150
<b>For Standard and Pro CPU</b>						
1x 3 poles for power supply, 1x 13 + 1x 12 poles I/O terminal blocks	Screw	5 mm pitch	Side	TA5212-TSCL	1SAP187400R0004	0.200
1x 3 poles for power supply, 1x 13 + 1x 12 poles I/O terminal blocks	Spring	5 mm pitch	Front	TA5212-TSPF	1SAP187400R0005	0.200

Only ABB terminal blocks must be used with AC500-eCo V3.



TA5211-TSCL-B

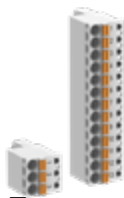

TA5211-TSPF-B

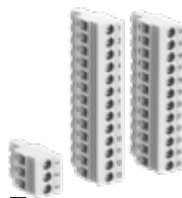

TA5212-TSCL



TA5212-TSPF

#### Accessories for AC500-eCo V3 CPUs

Description	Type	Order code	Price	Weight (1 set) kg
<b>For Basic CPU only</b>				
Real Time Clock without battery, option board for AC500-eCo Basic CPU	TA5131-RTC	1SAP187200R0002		0.150
<b>For all AC500-eCo V3 CPU types</b>				
Micro memory card 8 GB for program, data or firmware update, with adapter (1)	MC5102	1SAP180100R0002		0.020
Screw mounting accessory for AC500-eCo V3 CPU (same as PM595-4ETH-x), 20 pieces per packing unit	TA543	1SAP182800R0001		0.100
Cable binding pluggable accessory, 20 pieces per packing unit	TA5301-CFA	1SAP187500R0003		0.150
Option board cover, removable plastic part, 6 pieces per packing unit	TA5300-CVR	1SAP187500R0001		0.100
Input simulator, 6 switches, 24 V DC	TA5400-SIM	1SAP187600R0001		0.100

(1) For temporary use, e.g. firmware- or project-download to the CPU. Not to be used during vibration or shock.



TA5301-CFA



TA543



TA5300-CVR

## AC500-eCo

### Ordering data

#### AC500-eCo V3 option boards

- Up to three option board slots for extension according to CPU type
- All option board modules can be used on all option board slots of a CPU
- Up to three RS232 or RS485 serial interfaces using option boards
- Four different option boards for analog channels extension / Three different option boards for digital channels extension
- KNX push button address switch
- All the option boards are delivered with spring connector terminal block.

Description	Onboard I/Os DI/DO/AI/AO	Relay / Transistor outputs	Type	Order code	Price	Weight (1 pce) kg
<b>Option board for digital input/output channel extension</b>						
4 DI digital input channels 24 V DC, 5 pole spring/ cable front terminal 3.50 mm pitch	4 / - / - / -	-	TA5101-4DI	1SAP187000R0001		0.150
4 DO digital output channels transistor 24 V DC / 0.5A, 7 pole spring/cable front term. 3.50 mm pitch	- / 4 / - / -	Transistor	TA5105-4DOT	1SAP187000R0002		0.150
2 DI/2DO digital in/output chan. Trans. 24 V DC / 0.5A, 7 pole spring/cable front term. 3.50 mm pitch	2 / 2 / - / -	Transistor	TA5110-2DI2DOT	1SAP187000R0003		0.150
<b>Option board for analog input/output channel extension</b>						
2 AI analog input channels U/I, 0 ... 10V/0 ... 20mA, 6 pole spring/cable front term. 3.50 mm pitch	- / - / 2 / -	-	TA5120-2AI-UI (1)	1SAP187100R0001		0.150
2 AI analog input channels TC thermocoupler, 6 pole spring/cable front term. 3.50 mm pitch	- / - / 2 / -	-	TA5122-2AI-TC (1)	1SAP187100R0004		0.150
2 AI analog input channels RTD PT100, PT1000, 8 pole spring/cable front term. 3.50 mm pitch	- / - / 2 / -	-	TA5123-2AI-RTD (1)	1SAP187100R0002		0.150
2 AO analog output channels U/I, 0 ... 10V/0 ... 20mA, 6 pole spring/cable front term. 3.50 mm pitch	- / - / - / 2	-	TA5126-2AO-UI (1)	1SAP187100R0003		0.150

(1) In preparation



TA5101-4DI



TA5105-4DOT



TA5110-2DI2DOT



TA5120-2AI-UI



TA5126-2AO-UI



Slot 1



Slot 1

Slot 2



Slot 1

Slot 2

Slot 3



Slot 1

Slot 2

Slot 3

	Basic PM5012-x-ETH	Standard PM5032-x-ETH	PM5052-x-ETH	Pro PM5072-T-ETH
Option board slot 1	●	●	●	●
Option board slot 2	-	●	●	●
Option board slot 3	-	-	●	●
<b>Usable option board on AC500-eCo V3 CPU</b>				
TA5130-KNXPB	-	-	-	●, max 1
TA5131-RTC	●, max 1	-	-	-
TA5101-4DI	●	●	●	●
TA5105-4DOT	●	●	●	●
TA5110-2DI2DOT	●	●	●	●
TA5120-2AI-UI	●	●	●	●
TA5122-2AI-TC	●	●	●	●
TA5123-2AI-RTD	●	●	●	●
TA5126-2AO-UI	●	●	●	●
TA5141-RS232I	●	●	●	●
TA5142-RS485I	●	●	●	●
TA5142-RS485	●	●	●	●

## AC500-eCo

### Ordering data

Description	Communication type	Type	Order code	Price	Weight (1 pce) kg
<b>Option board for serial communication extension</b>					
RS232 serial adapter isolated, 5 pole spring/cable front terminal 3.50 mm pitch	RS232 isolated	TA5141-RS232I	1SAP187300R0001		0.150
RS485 serial adapter isolated, 5 pole spring/cable front terminal 3.50 mm pitch	RS485 isolated	TA5142-RS485I	1SAP187300R0002		0.150
RS485 serial adapter non-isolated, 5 pole spring/cable front terminal 3.50 mm pitch	RS485 non-isolated	TA5142-RS485	1SAP187300R0003		0.150
<b>Option board for communication address setting or real time clock</b>					
KNX address switch option board, 1 push button	-	TA5130-KNXPB	1SAP187200R0001		0.150
Real Time Clock without battery, option board for AC500-eCo Basic CPU only	-	TA5131-RTC	1SAP187200R0002		0.150

The necessary spring terminal blocks are delivered with each option board. Only ABB terminal blocks must be used with AC500-eCo V3.



TA5141-RS232I



TA5142-RS485I



TA5142-RS485



TA5130-KNXPB

Description	Type	Order code	Price	Weight (1 pce) kg
<b>Spare parts for option boards (terminal blocks)</b>				
TA5220-SPF5:S500, terminal block, 5 pole, spring front/cable front, pitch 3.5 mm, pack.unit: 6 piece	TA5220-SPF5	1SAP187400R0012		0.150
TA5220-SPF6:S500, terminal block, 6 pole, spring front/cable front, pitch 3.5 mm, pack.unit: 6 piece	TA5220-SPF6	1SAP187400R0013		0.170
TA5220-SPF7:S500, terminal block, 7 pole, spring front/cable front, pitch 3.5 mm, pack.unit: 6 piece	TA5220-SPF7	1SAP187400R0014		0.180
TA5220-SPF8:S500, terminal block, 8 pole, spring front/cable front, pitch 3.5 mm, pack.unit: 6 piece	TA5220-SPF8	1SAP187400R0015		0.200
TA5220-SPF9:S500, terminal block, 9 pole, spring front/cable front, pitch 3.5 mm, pack.unit: 6 piece	TA5220-SPF9	1SAP187400R0016		0.230

Only ABB terminal blocks must be used with AC500-eCo V3.



TA5220-SPF5



TA5220-SPF6



TA5220-SPF7

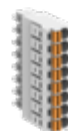

TA5220-SPF8

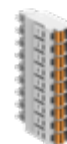

TA5220-SPF9

## AC500-eCo

### Ordering data

#### S500-eCo I/O modules

- For central extension of the AC500 or AC500-eCo CPUs
- For decentralized extension in combination with communication interface module DC551-CS31, CI52x-MODTCP, PROFINET CI50x modules, CI592-CS31, PROFIBUS modules CI54x, EtherCAT modules CI51x, and CANopen modules CI58x (not usable with DC505-FBP module and CI590-CS31-HA).

#### Digital I/O

- DC: Channels can be configured individually as inputs or outputs.

Number of DI/DO/DC	Input signal	Output type	Output signal	Terminal block required		Type	Order code	Price	Weight (1 pce) kg
				9 poles	11 poles				
8 / - / -	24 V AC / DC	-	-	1	-	DI561	1TNE968902R2101		0.12
16 / - / -	24 V AC / DC	-	-	1	1	DI562	1TNE968902R2102		0.12
8 / - / -	100-240 V AC	-	-	1	1	DI571	1TNE968902R2103		0.15
16 / - / -	100-240 V AC	-	-	1	1	DI572	1SAP230500R0000		0.19
- / 8 / -	-	Transistor	24 V DC, 0.5 A	-	1	DO561	1TNE968902R2201		0.12
- / 16 / -	-	Transistor	24 V DC, 0.5 A	1	1	DO562	1SAP230900R0000		0.16
- / 8 / -	-	Relay	24 V AC / DC, 120 / 240 V AC, 2 A	-	1	DO571	1TNE968902R2202		0.15
- / 8 / -	-	Triac	24 V AC, 100 / 240 V AC, 0.3 A	1	1	DO572	1TNE968902R2203		0.12
- / 16 / -	-	Relay	24 V DC, 120 / 240 V AC, 2 A	1	1	DO573	1SAP231300R0000		0.19
8 / 8 / -	24 V DC	Transistor	24 V DC, 0.5 A	1	1	DX561	1TNE968902R2301		0.12
8 / 8 / -	24 V AC / DC	Relay	24 V AC / DC, 120 / 240 V AC, 2 A	1	1	DX571	1TNE968902R2302		0.15
- / - / 16	24 V DC	Transistor	24 V DC, 0.5 A	1	1	DC562	1SAP231900R0000		0.15

Terminal blocks (9 or 11 poles) are necessary for each S500-eCo I/O. The terminal blocks must be ordered separately.

#### Analog I/O

- Each channel can be configured individually
- Resolution:
  - AI561, AO561, AX561: 12 bits/11 bits + sign
  - AI562, AI563: 15 bits + sign.

Number of AI/AO	Input signal	Output signal	Terminal block required		Type	Order code	Price	Weight (1 pce) kg
			9 poles	11 poles				
4 / 0	$\pm 2.5$ V, $\pm 5$ V, 0...5 V, 0...10 V, 0...20 mA, 4...20 mA	-	1	1	AI561	1TNE968902R1101		0.12
2 / 0	PT100, PT1000, Ni100, Ni1000, Resistance: 150 $\Omega$ , 300 $\Omega$	-	-	1	AI562	1TNE968902R1102		0.12
4 / 0	S, T, R, E, N, K, J, Voltage range: $\pm 80$ mV	-	1	1	AI563	1TNE968902R1103		0.12
0 / 2	-	-10...+10 V, 0...20 mA, 4...20 mA	-	1	AO561	1TNE968902R1201		0.12
4 / 2	$\pm 2.5$ V, $\pm 5$ V, 0...5 V, 0...10 V, 0...20 mA, 4...20 mA	-10...+10 V, 0...20 mA, 4...20 mA	1	1	AX561	1TNE968902R1301		0.13

Terminal blocks (9 or 11 poles) are necessary for each S500-eCo I/O. The terminal blocks must be ordered separately.



DI561



AI562



AX561



## AC500-eCo

### Ordering data

#### Positioning module

- For central extension of the AC500 or AC500-eCo CPUs
- For decentralized extension in combination with communication interface modules CI50X-PNIO or CI54X-DP
- The FM562 module provides Pulse Train Outputs for 2 axes. Profile generator integrated.

Number of axis	Input signal	Output signal	Terminal block required		Type	Order code	Price	Weight (1 pce) kg
			9 poles	11 poles				
2	4 digital inputs 24 V (2 per axis)	4 pulse outputs RS422 (2 per axis)	1	1	FM562	1SAP233100R0001		0.15

Terminal blocks (9 or 11 poles) are necessary for each S500-eCo I/O. The terminal blocks must be ordered separately. Library PS552-MC-E is required for programming this module.



FM562

#### Terminal blocks for S500-eCo I/O modules and AC500-eCo CPUs

Number of poles	Connection type	Cable entry	Type	Order code	Price	Weight (1 pce) kg
9	Screw	Side	TA563-9	1TNE968901R3101		0.017
11	Screw	Side	TA563-11	1TNE968901R3102		0.020
9	Screw	Front	TA564-9	1TNE968901R3103		0.026
11	Screw	Front	TA564-11	1TNE968901R3104		0.035
9	Spring	Front	TA565-9	1TNE968901R3105		0.016
11	Spring	Front	TA565-11	1TNE968901R3106		0.020



Only ABB terminal blocks must be used with AC500-eCo.  
Package unit for these terminal blocks = 6.



TA563-9



TA564-11



TA565-9

## AC500-eCo

### Technical data

#### AC500-eCo CPUs

Type	PM554-TP	PM554-RP	PM554-RP-AC		PM554-TP-ETH	PM556-TP-ETH
Supply voltage	24 V DC		100-240 V AC		24 V DC	
Current consumption on	24 V DC		100 V AC	240 V AC	24 V DC	
Min. (module alone)	0.06 A	0.08 A	0.02 A	0.012 A	0.07 A	0.07 A
Max. (I/Os)	0.18 A	0.22 A	0.2 A	0.11 A	0.19 A	0.19 A
Type of processor / Processor clock frequency	Freescale ARM Processor 32-bit / 50 MHz					
Total RAM memory / Total Flash memory	16 MB / 4 MB					
Total user program memory (3)	142 kB				654 kB	1666 kB
User program code	128 kB					
User data memory	14 kB thereof 2 kB saved				130 kB thereof 2 kB saved	
Web server's data for user RAM disk	-				512 kB	1024 kB
Data buffering (of saved data)	flash memory					
Real-time clock (option with battery back-up) (1)	●					
<b>Program execution</b>						
Cyclical	●					
Time controlled	●					
Multi tasking	no, 1 task + 1 interrupt task max.					
Interruption	●					
User program protection by password	●					
<b>Cycle time for 1 instruction (minimum)</b>						
Binary / Word / Floating	0.08 μs / 0.1 μs / 1.2 μs					
<b>Onboard digital inputs</b>						
Channels	8 (including 2 counter inputs, or up to 4 interrupt inputs)					
Signal voltage	24 V DC					
<b>Onboard digital outputs</b>						
Channels	6 (including 2 PWM outputs for types with transistor outputs)					
Relay / Transistor	Transistor	Relay	Relay	Relay	Transistor	Transistor
Rated voltage	24 V DC	240 V AC	240 V AC	240 V AC	24 V DC	24 V DC
Nominal current per channel	0.5 A	2 A resistive	2 A resistive	2 A resistive	0.5 A	0.5 A
<b>Onboard analog outputs</b>						
Channels	-					
signal ranges	-					
<b>Onboard analog inputs</b>						
Channels	-					
signal ranges	-					
<b>Max. number of centralized inputs/outputs</b>						
Max. number of extension modules on I/O bus	up to max. 10 (S500 and/or S500-eCo modules allowed)					
Digital	inputs	320 + 8				
	outputs	320 + 6				
Analog	inputs	160				
	outputs	160				
<b>Max. number of decentralized inputs/outputs</b>						
On CS31 bus	up to 31 stations with up to 120 DI / 120 DO each or up to 32 AI/32 AO per station					
<b>Internal interfaces</b>						
<b>COM1</b>						
RS485	●					
Sub-D connection	●					
Programming, Modbus-RTU, ASCII, CS31	●					
<b>COM2 (option) (2)</b>						
RS485 / RS485 isolated	● / ●					
Terminal block	●					
Programming, Modbus-RTU, ASCII	●					
<b>Ethernet</b>						
RJ45	-				●	
Ethernet functions: Programming, Modbus TCP/IP, UDP/IP, integrated	-				●	
Web server, DHCP, FTP server, SMTP client	-				-	
SMTP	-				-	
RUN/STOP switch	●					
LED for power, status and error	●					
<b>Approvals</b>	See detailed page 272 or <a href="http://www.abb.com/plc">www.abb.com/plc</a>					

(1) Real-time clock requires optional TA561-RTC or TA562-RS-RTC. (2) COM2 requires TA562-RS-RTC, TA562-RS or new TA569-RS-ISO.

(3) Total user program memory: contains user program code, data and web server

# AC500-eCo

## Technical data

### AC500-eCo CPUs

Type	PM564-TP	PM564-RP	PM564-RP-AC	
Supply voltage	24 V DC		100-240 V AC	
Current consumption on	24 V DC		100 V AC	240 V AC
Min. (module alone)	0.095 A	0.11 A	0.02 A	0.011 A
Max. (I/Os)	0.21 A	0.24 A	0.21 A	0.125 A
Type of processor / Processor clock frequency	Freescale ARM Processor 32-bit / 50 MHz			
Total RAM memory / Total Flash memory	16 MB / 4 MB			
Total user program memory (3)	142 kB			
User program code	128 kB			
User data memory	14 kB thereof 2 kB saved			
Web server's data for user RAM disk				
Data buffering (of saved data)	flash memory			
Real-time clock (option with battery back-up) (1)	●			
<b>Program execution</b>				
Cyclical	●			
Time controlled	●			
Multi tasking	no, 1 task + 1 interrupt task max.			
Interruption	●			
User program protection by password	●			
<b>Cycle time for 1 instruction (minimum)</b>				
Binary/Word/ Floating	0.08 μs / 0.1 μs / 1.2 μs			
<b>Onboard digital inputs</b>				
Channels	6 (including 2 counter inputs, or up to 4 interrupt inputs)			
Signal voltage	24 V DC			
<b>Onboard digital outputs</b>				
Channels	6 (including 2 PWM outputs for types with transistor outputs)			
Relay / Transistor	Transistor	Relay	Relay	
Rated voltage	24 V DC	240 V AC	240 V AC	
Nominal current per channel	0.5 A	2 A resistive	2 A resistive	
<b>Onboard analog inputs</b>				
Channels	2			
signal ranges	0...10 V / can be configured as digital input 24 V DC			
<b>Onboard analog outputs</b>				
Channels	1			
signal ranges	0...10 V / 0...20 mA / 4...20 mA			
<b>Max. number of centralized inputs/outputs</b>				
Max. number of extension modules on I/O bus	up to max. 10 (S500 and/or S500-eCo modules allowed)			
Digital	inputs	320 + 8		
	outputs	320 + 6		
Analog	inputs	160 + 2		
	outputs	160 + 1		
<b>Max. number of decentralized inputs/outputs</b>				
On CS31 bus	up to 31 stations with up to 120 DI / 120 DO each or up to 32 AI/32 AO per station			
<b>Internal interfaces</b>				
<b>COM1</b>				
RS485	●			
Sub-D connection	●			
Programming, Modbus-RTU, ASCII, CS31	●			
<b>COM2 (option) (2)</b>				
RS485 / RS485 isolated	● / ●			
Terminal block	●			
Programming, Modbus-RTU, ASCII	●			
<b>Ethernet</b>				
RJ45	-			
Ethernet functions: Programming, Modbus TCP/IP, UDP/IP, integrated Web server, DHCP, FTP server, SNMP client	-			
SMTP	-			
RUN/STOP switch	●			
LED for power, status and error	●			
<b>Approvals</b>	See detailed page 272 or <a href="http://www.abb.com/plc">www.abb.com/plc</a>			

(1) Real-time clock requires optional TA561-RTC or TA562-RS-RTC. (2) COM2 requires TA562-RS-RTC, TA562-RS or new TA569-RS-ISO.

(3) Total user program memory: contains user program code, data and web server

## AC500-eCo

### Technical data

#### AC500-eCo CPUs

Type	PM564-TP-ETH	PM566-TP-ETH	PM564-RP-ETH	PM564-RP-ETH-AC
Supply voltage	24 V DC			100-240 V AC
Current consumption on	24 V DC			100 V AC    240 V AC
Min. (module alone)	0.10 A	0.10 A	0.12 A	0.023 A    0.014 A
Max. (I/Os)	0.22 A	0.22 A	0.25 A	0.22 A    0.13 A
Type of processor / Processor clock frequency	Freescale ARM Processor 32-bit / 50 MHz			
Total RAM memory / Total Flash memory	16 MB / 4 MB			
Total user program memory (3)	654 kB	1666 kB	654 kB	
User program code	128 kB	512 kB	128 kB	
User data memory	14 kB thereof 2 kB saved	130 kB thereof 2 kB saved	14 kB thereof 2 kB saved	
Web server's data for user RAM disk	512 kB	1024 kB	512 kB	
Data buffering (of saved data)	flash memory			
Real-time clock (option with battery back-up) (1)	●			
<b>Program execution</b>				
Cyclical	●			
Time controlled	●			
Multi tasking	no, 1 task + 1 interrupt task max.			
Interruption	●			
User program protection by password	●			
<b>Cycle time for 1 instruction (minimum)</b>				
Binary / Word / Floating	0.08 μs / 0.1 μs / 1.2 μs			
<b>Onboard digital inputs</b>				
Channels	6 (including 2 counter inputs, or up to 4 interrupt inputs)			
Signal voltage	24 V DC			
<b>Onboard digital outputs</b>				
Channels	6 (including 2 PWM outputs for types with transistor outputs)			
Relay / Transistor	Transistor	Transistor	Relay	Relay
Rated voltage	24 V DC	24 V DC	240 V AC	240 V AC
Nominal current per channel	0.5 A	0.5 A	2 A resistive	2 A resistive
<b>Onboard analog inputs</b>				
Channels	2			
signal ranges	0...10 V / can be configured as digital input 24 V DC			
<b>Onboard analog outputs</b>				
Channels	1			
signal ranges	0...10 V / 0...20 mA / 4...20 mA			
<b>Max. number of centralized inputs/outputs</b>				
Max. number of extension modules on I/O bus	up to max. 10 (S500 and/or S500-eCo modules allowed)			
Digital	inputs	320 + 8		
	outputs	320 + 6		
Analog	inputs	160 + 2		
	outputs	160 + 1		
<b>Max. number of decentralized inputs/outputs</b>				
On CS31 bus	up to 31 stations with up to 120 DI / 120 DO each or up to 32 AI/32 AO per station			
<b>Internal interfaces</b>				
<b>COM1</b>				
RS485	●			
Sub-D connection	●			
Programming, Modbus-RTU, ASCII, CS31	●			
<b>COM2 (option) (2)</b>				
RS485 / RS485 isolated	● / ●			
Terminal block	●			
Programming, Modbus-RTU, ASCII	●			
<b>Ethernet</b>				
RJ45	●			
Ethernet functions: Programming, Modbus TCP/IP, UDP/IP, integrated Web server, DHCP, FTP server, SNMP client	●			
SMTP	–	●	–	–
RUN/STOP switch	●			
LED for power, status and error	●			
<b>Approvals</b>	See detailed page 272 or <a href="http://www.abb.com/plc">www.abb.com/plc</a>			

(1) Real-time clock requires optional TA561-RTC or TA562-RS-RTC. (2) COM2 requires TA562-RS-RTC, TA562-RS or new TA569-RS-ISO.

(3) Total user program memory: contains user program code, data and web server

## AC500-eCo

### Technical data

#### AC500-eCo V3 CPUs

Type	PM5012-T-ETH	PM5012-R-ETH	PM5032-T-ETH	PM5032-R-ETH	PM5052-T-ETH	PM5052-R-ETH	PM5072-T-2ETH	PM5072-T-2ETHW(2)
Supply voltage	24 V DC							
Current consumption on 24 V DC								
Min. typ. (module alone)	0.150 A	0.150 A	0.200 A	0.200 A	0.200 A	0.200 A	0.250 A	0.250 A
Max. typ. (all I/Os)	0.150 A	0.850 A	0.900 A	0.900 A	0.900 A	0.900 A	0.950 A	0.950 A
Type of processor / Processor clock frequency	TI ARM Cortex-A9 32-bit-RISC / 300 MHz							
Total RAM memory / Total Flash memory	128 MB / 128 MB							
Total user program memory (2)	1 MB	1 MB	2 MB	2 MB	4 MB	4 MB	8 MB	8 MB
Thereof User program code and data (dynamically allocated) (1)	256 kB	256 kB	512 kB	512 kB	768 kB	768 kB	1 MB	1 MB
Thereof User web server Data max.	-	-	1.5 MB	1.5 MB	3 MB	3 MB	7 MB	7 MB
User data memory saved in FLASH	8 kB	8 kB	32 kB	32 kB	32 kB	32 kB	100 kB	100 kB
Thereof VAR Retain persistent	4 kB	4 kB	16 kB	16 kB	16 kB	16 kB	36 kB	36 kB
Thereof % M memory (e.g. Modbus register)	4 kB	4 kB	16 kB	16 kB	16 kB	16 kB	64 kB	64 kB
User flash disk (Data-storage, programm - access or also external with FTP)	-							
Plug-in memory card (onboard micro memory card socket)	● Depending on micro memory card used: use MC5102 preferably							
Data buffering	Flash EPROM memory							
Real-time clock (with Goldcap back-up)	Optional, use option board TA5131-RTC ●							
<b>Cycle time for 1 instruction (minimum)</b>								
Binary / Word / Floating-point	0.02 µs / 0.02 µs / 0.60 µs							
<b>Program execution</b>								
Cyclical / Time controlled / multi tasking	● / ● / ●							
Minimum cycle time configurable for cyclical task	10 ms		5 ms		2 ms		1 ms	
User program protection by password	●							
<b>Onboard digital inputs</b>								
Channels	6 (thereof 4 high-speed 5 kHz)		12 (thereof 4 high-speed 200 kHz, 4 with 5 kHz)					
Functionality	up to 6 standard or		up to 12 standard or					
Fast counter	up to 2 (5kHz)		up to 4 (100 kHz)					
A/B Encoder with frequency measurement	up to 1 A/B encoder (5 kHz) without touch/reset input		up to 2 A/B encoder (200 kHz) with without Touch/Reset inputs					
Interrupt input with dedicated interrupt task	up to 4		up to 4					
Signal voltage	24 V DC		24 V DC					
<b>Onboard digital outputs</b>								
Channels								
Transistor	4 (thereof 4 high speed 5 kHz)	-	8 (thereof 4 high speed 100 kHz and 4 with 5 kHz)	-	8 (thereof 4 high speed 100 kHz and 4 with 5 kHz)	-	8 (thereof 4 high speed 100 kHz and 4 with 5 kHz)	
Functionality	Up to 4 standard or	-	up to 8 standard or	-	up to 8 standard or	-	up to 8 standard or	
PTO with pulse signal and direction	-	-	up to 2 (200 kHz)	-	up to 2 (200 kHz)	-	up to 2 (200 kHz)	
PTO with CC/CCW pulse outputs	-	-	up to 2 (200 kHz)	-	up to 2 (200 kHz)	-	up to 2 (200 kHz)	
PTO (SW using PWM) pulse and direction	-	-	up to 4 (100 kHz)	-	up to 4 (100 kHz)	-	-	
PWM	up to 4 (100 Hz)	-	up to 4 (30 kHz) and up to 4 (100 Hz)	-	up to 4 (30 kHz) and up to 4 (100 Hz)	-	up to 4 (30 kHz) and up to 4 (100 Hz)	
Limit switch	up to 4	-	up to 8	-	up to 8	-	up to 8	

(1) Memory size of V2 versus V3 CPUs is not comparable. Projects have a different and separate User Program code and Data memory calculation in Automation Builder 2.4.0 version or later. System, configuration and web server parts are not counted anymore. This results in typically about 50 % lower memory usage compared to V2, and even lower memory usage compared to V3 projects compiled in Automation Builder 2.3.0 or before.

(2) Total user program memory: contains user program code, data, web server memory, infrastructure



## AC500-eCo

### Technical data

#### AC500-eCo V3 CPUs

Type	PM5012-T-ETH	PM5012-R-ETH	PM5032-T-ETH	PM5032-R-ETH	PM5052-T-ETH	PM5052-R-ETH	PM5072-T-2ETH	PM5072-T-2ETHW(2)
Relay	-	4	-	6	-	6	-	-
Functionality	-	Standard output	-	Standard output	-	Standard output	-	-
Rated voltage	24 V DC	230 V AC	24 V DC	230 V AC	24 V DC	230 V AC	24 V DC	24 V DC
Nominal current per channel	0.5 A resistive	2 A resistive	0.5 A resistive	2 A resistive	0.5 A resistive	2 A resistive	0.5 A resistive	0.5 A resistive
<b>Onboard digital input /output configurable channels</b>								
Channels	-	-	2 digital in/output configurable					
As digital input used	-	-	up to 2					
Signal voltage	-	-	24 V DC					
Functionality	-	-	Standard input					
As digital output transistor used	-	-	up to 2 standard	up to 2 standard or	up to 2 standard	up to 2 standard or	up to 2 standard	up to 2 standard
PTO with pulse signal and direction	-	-	-	up to 1 (200 kHz)	-	up to 1 (200 kHz)	-	-
PTO with CC/CCW pulse outputs	-	-	-	up to 1 (200 kHz)	-	up to 1 (200 kHz)	-	-
PWM	-	-	-	up to 2 (30 kHz)	-	up to 2 (30 kHz)	-	-
Limit switch	-	-	-	up to 2	-	up to 2	-	-
Rated voltage	-	-	24 V DC	24 V DC	24 V DC	24 V DC	24 V DC	24 V DC
Nominal current per channel	-	-	0.5 A resistive	0.5 A resistive	0.5 A resistive	0.5 A resistive	0.5 A resistive	0.5 A resistive
<b>Max. number of centralized inputs/outputs</b>								
Max. number of extension modules on I/O bus	-	up to max. 10 (S500 and/or S500-eCo I/O modules allowed)						
<b>Maximum size of process image variable on I/O bus</b>	<b>onboard I/O + option board</b>	<b>128 Byte input and 128 Byte output</b>			<b>no limit within 10 I/O modules</b>			
Digital	inputs	only onboard 6 + 1 option board	320 + 12 + max. 2DC as 2DI + opt. boards			320 + 12 + max. 2DC as 2DI + option boards		
	outputs	only onboard 4 + 1 option board	320 + 8/6 + max. 2DC as 2DO + opt. boards			320 + 8/6 + max. 2DC as 2DO + option boards		
Analog	inputs	only 1 option board	max. 64 including option boards			160 + option boards		
	outputs	only 1 option board	max. 64 including option boards			160 + option boards		
Max. number of decentralized inputs/outputs	depends on the used standard fieldbus (1)							
<b>Option board slots for extension</b>	Each slot can be used for all type of existing option boards, same option board for serial interface or digital/analog I/O extension can be used on several slots per CPU							
Max. number of option board slots max.	1	2	3					
Type of option board								
KNX communication address switch	-							TA5130-KNXPB only on 1 slot
Real-time clock (with Goldcap back-up)	TA5131-RTC	-						
Serial interface	TA5141-RS232I, TA5142-RS485/TA5142-RS485I							
Digital in/output channels	TA5101-4DI, TA5105-4DOT, TA5110-2DI2DOT							
Analog in/output channels (1)	TA5120-2AI-UI, TA5122-2AI-TC, TA5123-2AI-RTD, TA5126-2AO-UI							

(1) In preparation

## AC500-eCo

### Technical data

#### AC500-eCo V3 CPUs

Type	PM5012-T-ETH	PM5012-R-ETH	PM5032-T-ETH	PM5032-R-ETH	PM5052-T-ETH	PM5052-R-ETH	PM5072-T-2ETH	PM5072-T-2ETHW(2)
<b>Internal interfaces for communication</b>								
COMx	No onboard serial interface, only using additional option boards for serial communication TA5141-RS232I, TA5142-RS485, TA5142-RS485I							
Number of serial interface maximum	1	2			3			
RS232 isolated	● (TA5141-RS232I)							
RS485 non isolated / Isolated	● (TA5142-RS485) / ● (TA5142-RS485I)							
Connection	pluggable spring terminal block delivered with option board							
Modbus RTU Master/Slave, ASCII	●							
Ethernet	1x Ethernet Interface						2x independent Ethernet interfaces for several uses	
Ethernet connection (on the CPU itself)	1x RJ45						2x RJ45 could be used as 2-port switch with 1x interface	
<b>Ethernet functions (2):</b>								
Ethernet Switch on ETH1 / ETH2 with 2x separated interfaces and MAC-Address	-	-	-	-	-	-	●	
Online Access, ICMP (Ping), DHCP	●							
Nb of parallel connections	4	4					6	
IP configuration protocol	●							
UDP data exchange, Network variables	● / ●							
HTTP / HTTPs (integrated Web server)	-	●						
Nb of parallel connections	-	2					4	
Web Visu for data visualisation on web server HTML5	-	●						
SNTP (Time synchronization) Server / Client	● / ●							
FTP / FTPs server	-	●						
Nb of parallel connections	-	2						
SMTP client	●							
Socket programming	●							
<b>Modbus TCP Client / Server</b>	● / ●							
Nr of Modbus clients ModMast in parallel on a CPU Master (Server)	8	13			20		30	
Nr of Modbus server in parallel (for SCADA access e.g.)	3	8			10		15	
<b>IEC 60870-5-104 remote control protocol - Support 2nd connection</b>	-							
Nr of free tags + additional license for extension (1)	-						1000	
Control Station - Nb connections	-						-	
Sub-Station - Nb connections	-						5	
<b>OPC UA Server (Micro Embedded Device Server) with security</b>	-							
Nr of free tags + additional license for extension (1)	-	125			250		1000	
Nr of Connections	-	5					10	
min sampling rate (limit)	-	1000 ms						
<b>OPC DA Server AE</b>	●							
Nr of Connections	4	4					6	

(1) In preparation

(2) Using parallel protocols on the same and/or different port reduces the bandwidth and the CPU performance

## AC500-eCo

### Technical data

#### AC500-eCo V3 CPUs

Type	PM5012-T-ETH	PM5012-R-ETH	PM5032-T-ETH	PM5032-R-ETH	PM5052-T-ETH	PM5052-R-ETH	PM5072-T-2ETH	PM5072-T-2ETHW(2)
<b>Ethernet-based fieldbus protocols (3)</b>	The number of allowed variables is depending on the protocol used							
Downloadable protocols (licensed feature with runtime license per CPU):								available on one Ethernet interface, the other interface can be sometimes used as switch
<b>Ethernet/IP Scanner communication</b>			● (1)(2)					● (1)(2)
<b>Ethernet/IP Adapter communication</b>			● (1)(2)					● (1)(2)
Maximum allowed number of input/output variables for the onboard fieldbus protocol	-	-	0.5 kB / 0.5 kB					0.5 kB / 0.5 kB
<b>IEC 61850 - MMS server Edition 1 / GOOSE communication</b>	-	-	-	-	-	-		● / ● (2)
Maximum number of allowed data attributes in variables list	-	-	-	-	-	-		1000
<b>KNX - Building communication</b>	-	-	-	-	-	-		● (2)
Maximum number of allowed Objects variables on the interface	-	-	-	-	-	-		1000
<b>BACnet-BC - Infrastructure communication</b>	-	-	-	-	-	-		● (2)
Maximum number of allowed Objects variables on the interface	-	-	-	-	-	-		1000
<b>Diagnostic and function</b>								
RUN/STOP switch	● (Toggle switch)							
LEDs for various status display	●							
Timer/Counter	unlimited/unlimited							
<b>Approvals</b>	See detailed page 272 or <a href="http://www.abb.com/plc">www.abb.com/plc</a>							

(1) In preparation

(2) Feature is licensed, runtime license per CPU.

(3) Using parallel protocols on the same and/or different port reduces the bandwidth and the CPU performance

## AC500-eCo

### Technical data

#### Digital S500-eCo I/O modules

Type	DI561	DI562	DI571	DI572	DO561	DO562
Supply voltage	-	-	-	-	24 V DC	24 V DC
Current consumption on UP						
Max. (without load current)	-	-	-	-	0.005 A	0.005 A
<b>Number of channels per module</b>						
Digital						
inputs	8	16	8 (AC)	16 (AC)	-	-
outputs	-	-	-	-	8	16
Configurable as Input or Output DC	-	-	-	-	-	-
Relay / Transistor	-	-	-	-	Transistor	Transistor
<b>Additional configuration of channels as:</b>						
Fast Counter	no				not applicable	
<b>Digital inputs</b>						
Input signal voltage	24 V AC / DC	24 V AC / DC	100-240 V AC	100-240 V AC	-	-
Input time delay	typically 8 ms	typically 8 ms	typically 15 ms / 30 ms	typically 15 ms / 30 ms	-	-
<b>Input current per channel</b>						
At Input voltage						
24 V AC / DC	typically 5 mA	typically 5 mA	-	-	-	-
5 V AC / DC	typically 1 mA	typically 1 mA	-	-	-	-
14 V AC	typically 2.7 mA	typically 2.7 mA	-	-	-	-
15 V DC	> 2.5 mA	> 2.5 mA	-	-	-	-
27 V AC	typically 5.5 mA	typically 5.5 mA	-	-	-	-
30 V DC	< 8 mA	< 8 mA	-	-	-	-
40 V AC	-	-	< 3 mA	< 3 mA	-	-
164 V AC	-	-	> 6 mA	> 6 mA	-	-
<b>Output current</b>						
Nominal current per channel	-	-	-	-	0.5 A	
Maximum (total current of all channels)	-	-	-	-	4 A	8 A
Residual current at signal state 0	-	-	-	-	< 0.5 mA	
Demagnetization when switching off inductive loads	-	-	-	-	must be provided externally	
<b>Switching frequency</b>						
For resistive load	-	-	-	-	limited by CPU cycle time	
For inductive load	-	-	-	-	max. 0.5 Hz	
For lamp load	-	-	-	-	max. 11 Hz at max. 5 W	
Short circuit / overload proofness	-	-	-	-	no	
Overload indication (I > 0.7 A)	-	-	-	-	no	
Output current limiting	-	-	-	-	no	
Resistance against reverse feeding of 24 V signals	-	-	-	-	no	
<b>Contact rating</b>						
For resistive load, max.	-	-	-	-	-	-
For inductive load, max.	-	-	-	-	-	-
For lamp load	-	-	-	-	-	-
<b>Lifetime (switching cycles)</b>						
Mechanical lifetime	-	-	-	-	-	-
Lifetime under load	-	-	-	-	-	-
<b>Maximum cable length for connected process signals</b>						
Cable						
shielded	500 m					
unshielded	300 m				150 m	
<b>Potential isolation</b>						
Per module	●	●	●	●	●	●
Between the channels						
input	-	per group of 8	●	per group of 8	-	-
output	-	-	-	-	-	-
Voltage supply for the module's logic	internal via I/O bus					
<b>Fieldbus connection</b>						
Suitable communication interface module	CI501-PNIO, CI502-PNIO, CI504-PNIO, CI506-PNIO, CI511-ETHCAT, CI512-ETHCAT, CI541-DP, CI542-DP, CI581-CN, CI582-CN, DC551-CS31, CI592-CS31, CI521-MODTCP, CI522-MODTCP					

## AC500-eCo

### Technical data

#### Digital I/O option board modules

Type	TA5101-4DI	TA5105-4DOT	TA5110-2DI2DOT
Supply voltage	–	24 V DC	24 V DC
Current consumption on UP			
Max. (without load current)	–	0.002 A	0.002 A
<b>Number of channels per module</b>			
Digital			
inputs	4	–	2
outputs	–	4	2
Configurable as Input or Output DC	–	–	–
Relay / Transistor	–	Transistor	Transistor
<b>Additional configuration of channels as:</b>			
Fast Counter	no	no	no
<b>Digital inputs</b>			
Input signal voltage	24 V DC	–	24 V DC
Input time delay	typically 4...8 ms	–	typically 4...8 ms
<b>Input current per channel</b>			
At Input voltage	24 V DC	typically 5 mA	–
	5 V DC	typically 1 mA	–
	15 V DC	> 2.5 mA	–
	30 V DC	< 7 mA	–
			typically 5 mA
			typically 1 mA
			> 2.5 mA
			< 7 mA
<b>Output current</b>			
Nominal current per channel	–	0.5 A	0.5 A
Maximum (total current of all channels)	–	2 A	1 A
Residual current at signal state 0	–	< 0.5 mA	
Demagnetization when switching off inductive loads	–	must be provided externally	must be provided externally
<b>Switching frequency</b>			
For resistive load	–	limited by CPU cycle time	limited by CPU cycle time
For inductive load	–	max. 0.5 Hz	max. 0.5 Hz
For lamp load	–	max. 11 Hz at max. 5 W	max. 11 Hz at max. 5 W
Short circuit / overload proofness	–	no	no
Overload indication (I > 0.7 A)	–	no	no
Output current limiting	–	no	no
Resistance against reverse feeding of 24 V signals	–	no	no
<b>Contact rating</b>			
For resistive load, max.	–	–	–
For inductive load, max.	–	–	–
For lamp load	–	–	–
<b>Lifetime (switching cycles)</b>			
Mechanical lifetime	–	–	–
Lifetime under load	–	–	–
<b>Maximum cable length for connected process signals</b>			
Cable			
shielded	500 m		
unshielded	300 m	150 m	150 m
<b>Potential isolation</b>			
Per module	● Use a separated power supply for the process voltage UP/ZP for isolation of the channels against CPU power supply		
Between the channels			
input	per group of 4	–	per group of 2
output	–	per group of 4	per group of 2
Voltage supply for the module's logic	internal via option board bus partly, mostly by external process supply (UP/ZP), when the supply voltage is not present, the option board doesn't functioning		



## AC500-eCo

### Technical data

#### Analog I/O option board modules – Preliminary information (1)

Type	TA5120-2AI-UI	TA5122-2AI-TC	TA5123-2AI-RTD	TA5126-2AO-UI
Supply voltage	24 V DC			
Current consumption on UP				
Max. (without load current)	0.050 A	0.050 A	0.050 A	0.070 A
<b>Number of channels per module</b>				
Analog				
inputs	2	2	2	–
outputs	–	–	–	2
<b>Inputs, individually configurable</b>				
0...10 V	12 bits	●	–	–
0...20 mA, 4...20 mA	12 bits	●	–	–
RTD	15 bits + sign	–	–	2
Pt100	-50...+400 °C (2/3-wire)	–	–	●
Pt1000	-50...+400 °C (2/3-wire)	–	–	●
Ni100 / Ni1000	-50...+150 °C (2/3-wire)	–	–	●
Resistor	0...150 Ω	–	●	–
NTC 10K, NTC 20K	-40...+110 °C	–	–	●
Thermocouple	Types J, K, T, N, S, E, R	–	●	–
Resolution of temperature measurement 0.1 °C	–	–	●	–
<b>Outputs, individually configurable</b>				
-10...+10 V	16 bits	–	–	●
0...20 mA	16 bits	–	–	●
4...20 mA	16 bits	–	–	●
<b>Potential isolation</b>				
Per module	● Use a separated power supply for the process voltage UP/ZP for isolation of the channels against CPU power supply			
Analog				
inputs	per group of 2	per group of 2	per group of 2	–
outputs	–	–	–	per group of 2
Voltage supply for the module's logic	internal via option board bus partly, mostly by external process supply (UP/ZP), when the supply voltage is not present, the option board doesn't function			

(1) In preparation

## AC500-eCo

### Technical data

#### Serial interface option board modules

Type	TA5141-RS232I	TA5142-RS485I	TA5142-RS485
Supply voltage	–	–	–
Current consumption on UP			
Max. (without load current)	–	–	–
<b>Number of channels per option board module</b>			
COMx	1	1	1
Nb of option board usable on an AC500-eCo V3 CPU	Up to 3 option boards can be used at a same time on a CPU according to their type		
<b>Serial interface</b>			
RS232 isolated	●	–	–
RS485 isolated	–	●	–
RS485 non isolated	–	–	●
Switchable End Of Line termination	–	●	●
Switchable line polarisation	–	●	●
Programming	–		
Modbus-RTU Master/Slave	●		
ASCII communication	●		
Terminal block	5 pole spring/cable front terminal 3.50 mm pitch, delivered with the option board		
<b>Maximal cable length for connected interface</b>			
Cable	shielded	x m	x m
<b>Potential isolation</b>			
Per module	●	●	–
Voltage supply for the module's logic	internal via option board bus		

## AC500-eCo

### Technical data

#### Digital S500-eCo I/O modules

Type	D0571	D0572	D0573
Supply voltage	24 V DC		
Current consumption on UP			
Max. (without load current)	0.050 A	–	0.050 A
<b>Number of channels per module</b>			
Digital			
inputs	–	–	–
outputs	8	8	16
Configurable as Input or Output DC	–	–	–
Relay / Transistor	Relay (n.o.)	Triac (AC)	Relay (n.o.)
<b>Process voltage</b>			
DC	24 V	–	–
<b>Digital inputs</b>			
Input signal voltage	–	–	–
Input time delay	–	–	–
<b>Input current per channel</b>			
At Input voltage			
24 V DC	–	–	–
5 V DC	–	–	–
15 V DC	–	–	–
30 V DC	–	–	–
<b>Output current</b>			
Nominal current per channel	2 A	0.3 A	2 A
Maximum (total current of all channels)	2 x 8 A	2.4 A	max 10 A per group (20 A per module)
Residual current at signal state 0	–	1.1 mA rms at 132 V AC and 1.8 mA rms at 264 V AC	–
Demagnetization when switching off inductive loads	must be performed externally		
<b>Switching frequency</b>			
For resistive load	1 Hz max.	10 Hz max.	1 Hz max.
For inductive load	–	–	–
For lamp load	1 Hz max.	10 Hz max.	1 Hz max.
Short circuit / overload proofness	no		
Overload indication (I > 0.7 A)	no		
Output current limiting	no		
Resistance against reverse feeding of 24 V signals	●	–	●
<b>Output rating for different loads</b>			
For resistive load, max.	2 A	0.3 A	2 A
For inductive load, max.	–	–	–
For lamp load	200 W at 230 V AC 30 W at 24 V DC	–	200 W at 230 V AC 30 W at 24 V DC
<b>Lifetime (switching cycles)</b>			
Mechanical lifetime	100 000	–	100 000
Lifetime under load	100 000 at rated load	–	100 000 at rated load
<b>Maximum cable length for connected process signals</b>			
Cable			
shielded	500 m		
unshielded	150 m		
<b>Potential isolation</b>			
Per module	between outputs and logic	●	between outputs and logic
Between the channels			
input	–	–	–
output	per group of 4	●	per group of 8
Voltage supply for the module's logic	internal via I/O bus		
<b>Fieldbus connection</b>			
Suitable communication interface module	CI501-PNIO, CI502-PNIO, CI504-PNIO, CI506-PNIO, CI511-ETHCAT, CI512-ETHCAT, CI541-DP, CI542-DP, CI581-CN, CI582-CN, DC551-CS31, CI592-CS31, CI521-MODTCP, CI522-MODTCP		

## AC500-eCo

### Technical data

#### Digital S500-eCo I/O modules

Type	DX561	DX571	DC562
Supply voltage	24 V DC		
Current consumption on UP			
Max. (without load current)	0.005 A	0.050 A	0.010 A
<b>Number of channels per module</b>			
Digital			
inputs	8	8	–
outputs	8	8	–
Configurable as Input or Output DC	–	–	16
Relays / Transistor	Transistor	Relay (n.o.)	Transistor
<b>Process voltage</b>			
DC	24 V	24 V	24 V
<b>Digital inputs</b>			
Input signal voltage	24 V DC	24 V AC / DC	24 V DC
Input time delay	typically 8 ms		typically 8 ms
<b>Input current per channel</b>			
At Input voltage			
24 V DC	typically 5 mA	typically 5 mA	typically 5 mA
24 V AC	–	typically 5 mA	–
5 V AC	–	typically 1 mA	–
5 V DC	< 1 mA	< 1 mA	typically 1 mA
14 V AC	–	typically 2.7 mA	–
27 V AC	–	typically 5.5 mA	–
15 V DC	> 2.5 mA	> 2.5 mA	> 2.5 mA
30 V DC	< 6.5 mA	< 6.5 mA	< 8 mA
<b>Output current</b>			
Nominal current per channel	0.5 A	2 A	0.5 A
Maximum (total current of all channels)	4 A	2 x 8 A	8 A
Residual current at signal state 0	< 0.5 mA	–	< 0.5 mA
Demagnetization when switching off inductive loads	must be performed externally		
<b>Switching frequency</b>			
For resistive load	Limited by CPU cycle time	1Hz max.	Limited by CPU cycle time
For inductive load	0.5 Hz max.	–	0.5 Hz max.
For lamp load	11 Hz max. at max. 5 W	1 Hz max.	11 Hz max. at max. 5 W
Short circuit / overload proofness	no		
Overload indication (I > 0.7 A)	no		
Output current limiting	no		
Resistance against reverse feeding of 24 V signals	no	yes	no
<b>Output rating for different loads</b>			
For resistive load, max.	–	2 A	–
For inductive load, max.	–	–	–
For lamp load	–	200 W at 230 V AC 30 W at 24 V DC	–
<b>Lifetime (switching cycles)</b>			
Mechanical lifetime	–	100 000	–
Lifetime under load	–	100 000 at rated Load DC-13 according to IEC 60947-5-1	–
<b>Maximum cable length for connected process signals</b>			
Cable			
shielded	500 m		
unshielded	150 m		
<b>Potential isolation</b>			
Per module	●	–	●
Between the channels			
input	–	per group of 8	–
output	–	per group of 4	–
Voltage supply for the module's logic	internal via I/O bus		
<b>Fieldbus connection</b>			
Suitable communication interface module	CI501-PNIO, CI502-PNIO, CI504-PNIO, CI506-PNIO, CI511-ETHCAT, CI512-ETHCAT, CI541-DP, CI542-DP, CI581-CN, CI582-CN, DC551-CS31, CI592-CS31, CI521-MODTCP, CI522-MODTCP		

## AC500-eCo

### Technical data

#### Analog S500-eCo I/O modules

Type		AI561	AO561	AX561	AI562	AI563
Supply voltage		24 V DC				
Current consumption on UP						
Max. (without load current)		0.100 A	0.100 A	0.140 A	0.040 A	0.100 A
<b>Number of channels per module</b>						
Analog	inputs	4	–	4	2	4
	outputs	–	2	2	–	–
<b>Inputs, individually configurable</b>						
-2.5...+2.5 V	11 bits + sign	●	–	●	–	–
-5...+5 V	11 bits + sign	●	–	●	–	–
-10...+10 V	11 bits + sign	–	–	–	–	–
0...5 V	12 bits	●	–	●	–	–
0...10 V	12 bits	●	–	●	–	–
0...20 mA, 4...20 mA	12 bits	●	–	●	–	–
RTD		–	–	–	2	–
Pt100	-50...+400 °C (2/3-wire)	–	–	–	●	–
Pt1000	-50...+400 °C (2/3-wire)	–	–	–	●	–
Ni100 / Ni1000	-50...+150 °C (2/3-wire)	–	–	–	●	–
Resistor	0...150 Ω/0...300 Ω	–	–	–	●	–
Thermocouple	Types J, K, T, N, S, E, R	–	–	–	–	●
Voltage	-80...+80 mV	–	–	–	–	●
Resolution of temperature measurement 0.1 °C		–	–	–	●	●
<b>Outputs, individually configurable</b>						
-10...+10 V	11 bits + sign	–	●	●	–	–
0...20 mA	12 bits	–	●	●	–	–
4...20 mA	12 bits	–	●	●	–	–
<b>Potential isolation</b>						
Per module		–	–	–	●	●
<b>Fieldbus connection</b>						
Suitable communication interface module		CI501-PNIO, CI502-PNIO, CI504-PNIO, CI506-PNIO, CI511-ETHCAT, CI512-ETHCAT, CI541-DP, CI542-DP, CI581-CN, CI582-CN, DC551-CS31, CI592-CS31, CI521-MODTCP, CI522-MODTCP				



## AC500-eCo

### Technical data

#### FM562 positioning module

The FM562 module contains Pulse Train Outputs for 2 axes. Profile generator for simple motion control tasks are integrated. The RS422 outputs allow a direct connection to Stepper- or Servo drives. Function blocks in PLCopen motion control style allow the integration of the module in an application. These function blocks are contained in the library PS552-MC-E.

<b>Type</b>	<b>FM562</b>	
<b>Functionality</b>		
Number of axis	2	
Digital inputs	2 digital inputs per axis Function: for axis enable or limit switch	
Pulse outputs	Modes cw/ccw or pulse/direction Built in profile generators	
<b>Data of the digital inputs</b>		
Signal voltage	24 V DC	
Input current at 24 V DC	typically 5 mA	
Potential isolation	by groups of 2	
<b>Data of pulse outputs</b>		
Signal	RS422 (differential)	
Frequency range	0...250 kHz	
Potential isolation	RS422 outputs of both axes in one group isolated against the inputs, the process voltage and the PLC CPU logic	
<b>Maximum cable length for digital inputs</b>		
Cable	shielded	500 m
	unshielded	300 m
<b>Maximum cable length for pulse outputs</b>		
Cable	shielded	300 m
	unshielded	30 m
<b>Process voltage UP</b>		
Nominal voltage	24 V DC	
Current consumption on UP	typically 0.04 A	
Reverse polarity protection	●	
<b>Potential isolation</b>		
Per module	●	
Voltage supply for the internal logic	From UP / ZP with isolation	
<b>Fieldbus connection</b>		
Suitable communication interface module	CI501-PNIO, CI502-PNIO, CI504-PNIO, CI506-PNIO, CI541-DP, CI542-DP	

# AC500-eCo

## System data

### Environmental Conditions

#### Process and supply voltages

24 V DC	Voltage	24 V (-15 %, +20 %)
	Protection against reverse polarity	yes
100 V...240 V AC Wide Range Supply	Voltage	100...240 V (-15 %, +10 %)
	Frequency	50/60 Hz (-6 %, +4 %)
Allowed interruptions of power supply	DC supply	Interruption < 10 ms, time between 2 interruptions > 1 s, PS2
	AC supply	Interruption < 0.5 periods, time between 2 interruptions > 1 s

Important: Exceeding the maximum process and supply voltages could lead to unrecoverable damage of the system. The system could be destroyed. For the supply of the modules, power supply units according to PELV or SELV specifications must be used. The creepage distances and clearances meet the requirements of the overvoltage category II, pollution degree 2.

#### Assembly position

Horizontal	•
Vertical	•

#### Temperature

Operating	0 °C ... +60 °C and -20 °C ... +70 °C for W version	Preferred mounting position horizontal. Other mounting positions see manual.
Storage / Transport	-40 °C ... +70 °C	

#### Humidity

Operating / Storage	Max 95 % r. H. without condensation
---------------------	-------------------------------------

#### Air pressure

Operating	-1000 m ... 2000 m (1080 hPa ... 800 hPa)
Storage	<3500 m (>660 hPa)

#### Electromagnetic Compatibility

Radiated emission (radio disturbances)	Yes, in accordance with CISPR 16-2-3
Conducted emission (radio disturbances)	Yes, in accordance with CISPR 16-2-1, CISPR 16-1-2
Electrostatic discharge (ESD)	Yes, in accordance with IEC 61000-4-2, zone B, criterion B Electrostatic voltage in case of air discharge: 8 kV Electrostatic voltage in case of contact discharge: 6 kV
Fast transient interference voltages (burst)	Yes, in accordance with IEC 61000-4-4, zone B, criterion B Supply voltage units (DC): 2 kV Supply voltage units (AC): 2 kV Digital inputs/outputs (24 V DC): 1 kV Digital inputs/outputs (100...240 V AC): 2 kV Analog inputs/outputs: 1 kV Communication lines shielded: 1 kV I/O supply (DC-out): 1 kV
High energy transient interference voltages (surge)	Yes, in accordance with IEC 61000-4-5, zone B, criterion B Supply voltage units (DC): 1 kV CM* / 0.5 kV DM* Supply voltage units (AC): 2 kV CM* / 1 kV DM* Digital inputs/outputs (24 V DC): 1 kV CM* / 0.5 kV DM* Digital inputs/outputs (100...240 V AC): 2 kV CM* / 1 kV DM* Analog inputs/outputs: 1 kV CM* / 0.5 kV DM* Communication lines shielded: 1 kV CM* I/O supply (DC-out): 0.5 kV CM* / 0.5 kV DM* * CM = Common Mode, * DM = Differential Mode
Influence of radiated disturbances	Yes, in accordance with IEC 61000-4-3, zone B, criterion A Test field strength: 10 V/m
Influence of line-conducted interferences	Yes, in accordance with IEC 61000-4-6, zone B, criterion A Test voltage: 10 V
Influence of power frequency magnetic fields	Yes, in accordance with IEC 61000-4-8, zone B, criterion A 30 A/m 50 Hz 30 A/m 60 Hz

#### WARNING!

##### Risk of malfunctions and damages to persons!

Unused slots for communication modules are not protected against contact discharge. Dust and Dirt may cause contact problems and malfunctions.

I/O-Bus connectors must not be touched during operation.

In order to prevent malfunctions, it is recommended that the operating personnel discharge themselves prior to touching communication connectors or perform other suitable measures to reduce effects of electrostatic discharges.

## AC500-eCo

### System data

#### Environmental Conditions

##### Environmental Tests

Storage	IEC 60068-2-1 Test Ab: cold withstand test -40 °C / 16 h
	IEC 60068-2-2 Test Bb: dry heat withstand test +70 °C / 16 h
Humidity	IEC 60068-2-30 Test Db: Cyclic (12 h / 12 h) Damp-Heat Test 55 °C, 93 % r. H. / 25 °C, 95 % r. H., 2 cycles
Vibration resistance	IEC 61131-2 / IEC 60068-2-6: 5 Hz ... 150 Hz, 1 g (with Memory Card inserted)
Shock resistance	IEC 60068-2-27: all 3 axes 15 g, 11 ms, half-sinusoidal

##### Mechanical Data

Wiring method	Spring terminals / Screw terminals	
Degree of protection	IP 20	
Assembly on DIN rail	DIN rail type	According to IEC 60715
		35 mm, depth 7.5 mm or 15 mm
Assembly with screws	Screw diameter	4 mm
	Fastening torque	1.2 Nm

#### Main dimensions mm, inches

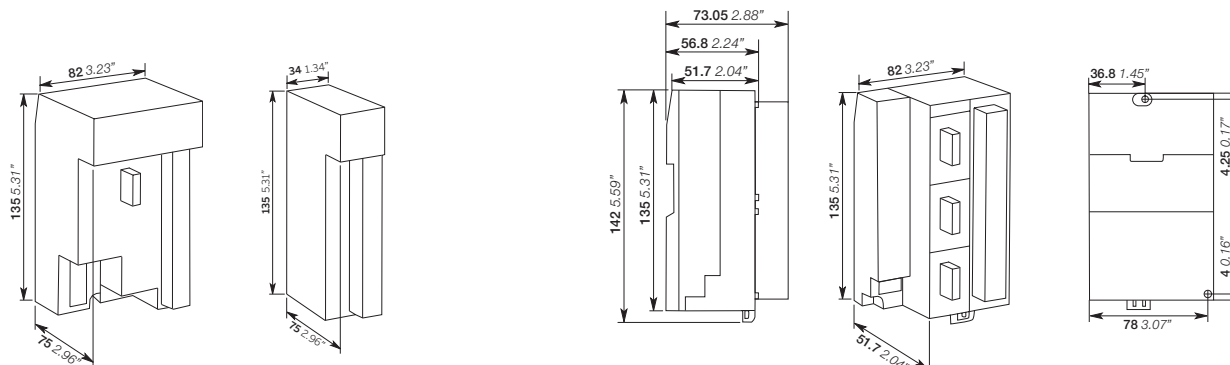







---

# AC500

High performance  
modular PLC

<b>103</b>	<b>Key features</b>
<b>104–117</b>	<b>Ordering data</b>
<b>118–147</b>	<b>Technical data</b>
<b>148–149</b>	<b>System data</b>

ABB

PM592

SYS  
BATT  
I/O-Bus

run

ETH  
FBP  
COM1  
COM2

PWR



RUN



ERR



RUN

DIAG

VAL

CFG

ESC



OK



MC  
502

← INSERT  
→ PUSH

WARNING

Use of  
incorrect  
battery may  
cause fire or  
explosion.

UP 24VDC 10W

CPU

# AC500

## Key features



—

- A high performance PLC:
  - Large memory up to 160 MB
  - Highly modular
  - From 8 to +80 000 I/Os
  - More communication possibilities (Ethernet, Internet, PROFINET, PROFIBUS, Modbus, CANopen, EtherCAT, Ethernet/IP, BACnet, KNX, OPC UA, OPC DA, IEC 60870-5-104, IEC 61850, MQTT, ...)

—

- Common AC500 platform benefits: ABB Ability™ Automation Builder engineering suite, I/O modules, scalable and flexible

- 
- Eight programming languages available (five IEC 61131-3, CFC, C-code and C++)
  - Object oriented engineering
  - Virtual controller
  - Web Visu
  - Data logging
  - Memory card for program back-up
  - High Availability (HA) option
  - Screw or spring terminal for I/Os
  - Extensive programming libraries

## AC500

### Ordering data

#### AC500 CPUs

- 2 internal serial interfaces, RS232 / RS485 configurable
- Display and 8 function keys for diagnosis and status
- Can be centrally extended with up to 10 I/O modules, 320 I/Os (S500 and/or S500-eCo modules allowed)
- Simultaneous operation of up to 4 external communication modules in any desired combination
- Optional memory card for data storage and program backup
- Can also be used as slave on PROFIBUS DP, CANopen or PROFINET IO using CM582-DP, CM588-CN, CM589-PNIO or CM589-PNIO-4 communication modules
- Ethernet version provides web server and IEC 60870-5-104 remote control protocol
- Support of AC500-S safety PLC.

Program memory kB	Cycle time in $\mu$ s per instruction min. Bit/Word/Float. point	Integrated communication	Type	Order code	Price	Weight (1 pce) kg
128	0.06 / 0.09 / 0.7	2 x serial	PM572	1SAP130200R0200		0.135
512	0.06 / 0.09 / 0.7	Ethernet (1), 2 x serial	PM573-ETH	1SAP130300R0271		0.150
512	0.05 / 0.06 / 0.5	2 x serial	PM582	1SAP140200R0201		0.135
1024	0.05 / 0.06 / 0.5	Ethernet (1), 2 x serial	PM583-ETH	1SAP140300R0271		0.150
1024	0.004 / 0.008 / 0.008	Ethernet (1), 2 x serial	PM585-ETH	1SAP140500R0271		0.150
2048	0.002 / 0.004 / 0.004	Ethernet (1), 2 x serial	PM590-ETH	1SAP150000R0271		0.150
2048	0.002 / 0.004 / 0.004	ARCNET BNC, 2 x serial	PM590-ARCNET	1SAP150000R0261		0.150
4096	0.002 / 0.004 / 0.004	Ethernet (1), 2 x serial	PM591-ETH	1SAP150100R0271		0.150
4096	0.002 / 0.004 / 0.004	2 x Ethernet (1), 1 x serial	PM591-2ETH (3)	1SAP150100R0277		0.150
4096	0.002 / 0.004 / 0.004	Ethernet (1), 2 x serial	PM592-ETH (2)	1SAP150200R0271		0.150

#### AC500 Machine controller kits

- Complete product bundle providing all the needed devices for a machine controller delivered under one single order code

Program memory kB	Cycle time in $\mu$ s per instruction min. Bit/Word/Float. point	Contents / Integrated communication	Type	Order code	Price	Weight (1 pce) kg
1024	0.004 / 0.008 / 0.008	PM585-ETH, CM579-ETHCAT, TB511-ETH Ethernet (1), 2 x serial, EtherCAT Master	PM585-MC-KIT	1SAP140500R0379		0.500
2048	0.002 / 0.004 / 0.004	PM590-ETH, CM579-ETHCAT, TB521-ETH, TA524 Ethernet (1), 2 x serial, EtherCAT Master	PM590-MC-KIT	1SAP150000R0379		0.500

(1) Provides integrated web server and IEC 60870-5-104 remote control protocol on each interface independently.

(2) Provides integrated 4 GB flash disk for user data storage and data logging.

(3) Only to be used with dedicated terminal base TB523-2ETH.



PM572



PM592



PM585-MC-KIT

## AC500

### Ordering data

#### AC500 CPU PM595

- 2 Ethernet interfaces with integrated switch and software configurable protocol (PROFINET, EtherCAT or Ethernet e.g. Modbus TCP)
- 2 independent Ethernet interfaces for programming, online access, web server, Modbus TCP, IEC 60870-5-104 protocol e.g.
- 2 serial interfaces, RS232 / RS485 configurable
- Can be centrally extended with up to 10 I/O modules (S500 and/or S500-eCo modules allowed)
- Simultaneous operation of up to 2 external communication modules in any desired combination, no need of additional terminal base

Program memory MB	Cycle time in $\mu$ s per instruction min. Bit/Word/Float. point	Integrated communication	Type	Order code	Price	Weight (1 pce) kg
16	0.0006/0.001/0.001	2 x Ethernet for fieldbus (2 Ports switch), 2 x Ethernet (1), 2 x serial	PM595-4ETH-F (2)	1SAP155500R0279		1.050

(1) Provides integrated web server and IEC 60870-5-104 remote control protocol on each interface independently.

(2) Provides integrated 4 GB flash disk for user data storage and data logging.



PM595-4ETH-F

## AC500

### Ordering data

#### Terminal base

- For mounting and connection of the CPUs and communication modules (not needed for PM595)
- 1 to 4 plug-in communication modules
- Connection for communication coupler integrated in the CPU
- I/O interface for direct connection of up to 10 extension modules
- Fieldbus-neutral FieldBusPlug-Slave interface (not for TB523-2ETH)
- Connection COM1: 9-pole pluggable terminal block
- Connection COM2: D-Sub 9 (not for TB523-2ETH).

Number of coupler slots	Connection for coupler integrated in the CPU	Type	Order code	Price	Weight (1 pce) kg
1	ARCNET BNC	TB511-ARCNET (2)	1SAP111100R0260		0.215
2	ARCNET BNC	TB521-ARCNET (2)	1SAP112100R0260		0.215
1	Ethernet RJ45	TB511-ETH	1SAP111100R0270		0.215
2	Ethernet RJ45	TB521-ETH	1SAP112100R0270		0.215
2	2x Ethernet RJ45	TB523-2ETH (1)	1SAP112300R0277		0.250
4	Ethernet RJ45	TB541-ETH	1SAP114100R0270		0.215

Note: These TBs are compatible with previous AC500 CPU versions (R01xx) and new ones (R02xx).

(1) Can only be used together the PM591-2ETH.

(2) Can be only used with PM590-ARCNET CPU.



TB511-ETH



TB541-ETH



## AC500

### Ordering data

#### AC500 Condition Monitoring CMS

- PLC integrated condition monitoring and fast protection for high frequency signals (vibration, current, voltage, speed/encoder)
- FM502-CMS module needs function module terminal base TF5x1 for direct interfacing to CPU, communication couplers, other I/O
  - for stand-alone or control/safety integrated condition monitoring
- PM592 CPU to be used on same TF5x1 for data storage and signal processing or communication
  - C-code interface for own complex diagnosis algorithms, 4GB Flash disk for raw fingerprints and indicator trending
- FM502-CMS module:
  - 16 fast, precise analog inputs, all synchronously sampled; configurable as IEPE or +-10V
  - individual measurement configuration (start,stop,trigger) per channel
  - per channel up to 50ksamples/s and 24bit ADC resolution, adjustable sampling
  - encoder inputs (5V or 24V) up to 300kHz counter; 12 modes, incl. absolute SSI (1MHz)
  - fast data logging, compact WAV-Files delivered automatically to CPU, incl. synchronized encoder signal if configured
  - analogue values always available for fast protection in I/O image of CPU
- Included in ABB Ability™ Automation Builder: Configuration, libraries for CMS control and wav file handling, examples
- Available download package: Signal processing library, example programs with simple diagnosis, logging and automated triggering (2)

Number of coupler slots	Description	Type	Order code	Price	Weight (1 pce) kg
n.a.	Function Module for Condition Monitoring Systems, 16AI, 2DI, 2DC, 1x Encoder (A, B, Z)	FM502-CMS	1SAP260400R0001		0.215
0	Function module terminal base for FM502, no coupler slots, 1x ETHERNET, 1x serial, spring terminals, 24 V DC	TF501-CMS (1)	1SAP117000R0271		0.350
2	Function module terminal base for FM502, 2x coupler slots, 1x ETHERNET, 1x serial, spring terminals, 24 V DC	TF521-CMS (1)	1SAP117200R0271		0.400

(1) Can only be used together with FM502 and PM592-ETH

(2) Download of Package under "Application Examples" at [www.abb.com/plc](http://www.abb.com/plc)



FM502-CMS



TF501-CMS



TF521-CMS

## AC500

### Ordering data

#### AC500 V3 CPUs

- 1x internal serial interface, RS232 / RS485 configurable (ACSII or Modbus RTU Master/Slave)
- 2x independent Ethernet interfaces which can also be used as switch and software configurable protocols like Modbus TCP, IEC 60870-5-104, Ethernet/IP (2)(3), IEC 61850 (3), BACnet-BC (3) or KNX IP (3) controller
- Web server with Web Visu HTML5 with CP600 with web interface
- 1x internal CAN interface, with CANopen Master, CAN 2A/2B and J1939 protocols
- Display and 8 function keys for diagnosis and status
- Can be centrally extended with up to 10 I/O modules, 320 I/Os (S500 and/or S500-eCo modules allowed)
- Simultaneous operation of several external communication modules in any desired combination
- To be used exclusively with new TB56xx-2ETH
- Optional memory card for data storage and program backup
- To be used only with ABB Ability™ Automation Builder 2.1 and later
- Support of AC500-S safety PLC

Total user program memory MB (5)(6)	Cycle time in µs per instruction min. Bit/Word/Float. point	Integrated communication	Type	Order code	Price	Weight (1 pce) kg
8 (thereof 2 for User Prog. code + Data)	0.020 / 0.020 / 0.120	2 x Ethernet with configurable protocol Ethernet/IP (2)(3), 1 x serial, 1x CAN interface	PM5630-2ETH (1) (4)	1SAP131000R0278		0.135
80 (thereof 8 for User Prog. code + Data)	0.010 / 0.010 / 0.010	2 x Ethernet with configurable protocols Ethernet/IP (2)(3), 1 x serial, 1x CAN interface	PM5650-2ETH (1) (4)	1SAP141000R0278		0.135
160 (thereof 32 for User Prog. code + Data)	0.002 / 0.002 / 0.002	2 x Ethernet with configurable protocol Ethernet/IP (2)(3), 1 x serial, 1x CAN interface	PM5670-2ETH (1) (4)	1SAP151000R0278		0.135
160 (thereof 32 for Prog. code + Data) / 8GB Flash disk	0.002 / 0.002 / 0.002	2 x Ethernet with configurable protocol Ethernet/IP (2)(3), 1 x serial, 1x CAN interface	PM5675-2ETH (1) (4)	1SAP151500R0278		0.150

(1) Ethernet communication provides integrated web server, IEC 60870-5-104 remote control protocol and OPC UA server on each interface independently.

(2) In preparation (3) Some communication protocols are licensed see following lines (4) Only to be used with dedicated terminal base TB56xx-2ETH

(5) Memory size of V2 versus V3 CPUs is not comparable. Projects have a different and separate User Program code and Data memory calculation in Automation Builder 2.4.0 version or later. System, configuration and web server parts are not counted anymore. This results in typically about 50% lower memory usage compared to V2, and even lower memory usage compared to V3 projects compiled in Automation Builder 2.3.0 or before.

(6) Total user program memory: contains user program code, data (dynamically allocated), web server memory and infrastructure



PM5630-2ETH



PM5650-2ETH



PM5670-2ETH



PM5675-2ETH

#### Feature licenses

Some HW or FW features need a license to be used on the new CPU. Which allows:

- more flexibility
- better adaptation to the needs

License Type	CPU runtime license to be used on internal Ethernet interface	Type	Order code
HW	Modbus TCP HA runtime license	PS5601-HA-MTCP	1SAP195400R0101
HW	IEC 61850 protocol runtime license	PS5602-61850	1SAP195600R0101
HW	Runtime license for KNX controller	PS5604-KNX	1SAP195800R0101
HW	BACnet protocol B-BC; runtime license	PS5607-BACnet-BC	1SAP195550R0101
HW	Motion control library runtime license	PS5611-MC	1SAP192150R0101
HW	Ethernet/IP scanner runtime license for AC500 V3 (1)	PS5613-EIP-S	1SAP196101R0101
HW	Ethernet/IP adapter runtime license for AC500 V3 (1)	PS5613-EIP-A	1SAP196100R0101

(1) In preparation

## AC500

### Ordering data

#### AC500 V3 Terminal base

- For mounting and connection of the AC500 V3 CPUs only and communication modules
- 0, 1, 2, 4 or up to 6 plug-in communication modules
- Connection for communication coupler integrated in the CPU
- I/O interface for direct connection of up to 10 extension modules
- Connection COM1: 9-pole pluggable spring terminal block
- Connection CAN: 2x 5-pole pluggable spring terminal block
- 2x RJ45 Ethernet interfaces with configurable switch functionality

Number of coupler slots	Connection for coupler integrated in the CPU	Type	Order code	Price	Weight (1 pce) kg
0	2x RJ45 for Ethernet, 1x serial COM1 with pluggable spring connector and 1x2x5 poles pluggable spring connector for CAN/CANopen interface	TB5600-2ETH	1SAP110300R0278		0.165
1		TB5610-2ETH	1SAP111300R0278		0.190
2		TB5620-2ETH	1SAP112300R0278		0.215
4		TB5640-2ETH	1SAP114300R0278		0.265
6		TB5660-2ETH	1SAP116300R0278		0.315



TB5600-2ETH



TB5610-2ETH



TB5620-2ETH



TB5640-2ETH



TB5660-2ETH

#### Terminal base compatibility

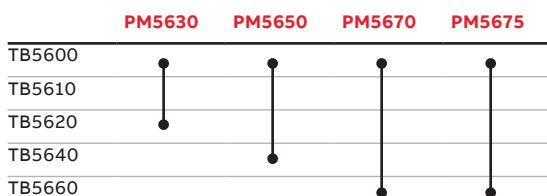

## AC500

### Ordering data

#### Communication modules

Protocol	Connections	CPU V3 Support	Type	Order code	Price	Weight (1 pce) kg
PROFIBUS DP V0/V1 master	D-Sub 9	(2)	CM592-DP	1SAP173200R0001		0.115
PROFIBUS DP V0/V1 slave	D-Sub 9	(2)	CM582-DP	1SAP172200R0001		0.115
Ethernet (TCP/IP, UDP/IP, Modbus TCP)	2 x RJ45 - integrated switch	-	CM597-ETH	1SAP173700R0001		0.115
CANopen master	Terminal block 2 x 5 poles spring	(1)	CM598-CN	1SAP173800R0001		0.115
CANopen slave	Terminal block 2 x 5 poles spring	-	CM588-CN	1SAP172800R0001		0.115
PROFINET IO RT controller	2 x RJ45 - integrated switch	Yes	CM579-PNIO	1SAP170901R0101		0.115
PROFINET IO RT device	2 x RJ45 - integrated switch	(2)	CM589-PNIO	1SAP172900R0011		0.115
PROFINET IO RT with 4 devices	2 x RJ45 - integrated switch	(2)	CM589-PNIO-4	1SAP172900R0111		0.115
EtherCAT master	2 x RJ45	Yes	CM579-ETHCAT	1SAP170902R0101		0.115
Serial + co-processor	2 x RS-232/485 on spring terminal blocks	-	CM574-RS	1SAP170400R0201		0.115
Serial RCOM	2 x RS-232/485 (1 x RCOM/1 x Console)	-	CM574-RCOM	1SAP170401R0201		0.115

(1) Only with CAN 2A/2B protocol

(2) In preparation



CM592-DP

CM574-RS  
CM574-RCOM

CM598-CN



CM579-PNIO

Protocol	Communication module	Communication interface module	I/O extension module			Applications	Support from CPU	
			S500	S500-eCo	S500-S		V2	V3
Modbus TCP	Onboard Ethernet interface	CI521-MODTCP / CI522-MODTCP	●	●	-	HA, remote I/O	●	●
	CM597-ETH		●	-	-	HA, remote I/O	●	-
PROFIBUS DP	CM592-DP master	CI541-DP / CI542-DP	●	●	-	remote I/O	●	● (1)
			●	-	-	hot-swap I/O	●	-
PROFINET IO RT	CM579-PNIO controller	CI501-PNIO / CI502-PNIO	●	●	●	remote I/O, safety I/O	●	●
			●	-	-	hot-swap I/O	●	●
		CI504-PNIO / CI506-PNIO	●	●	●	remote I/O, safety I/O	●	-
			●	-	-	hot-swap I/O	●	-
CANopen	Onboard CAN interface	CI581-CN / CI582-CN	-	-	-	remote I/O	-	● (2)
	CM598-CN master		●	●	-	remote I/O	●	-
EtherCAT	CM579-ETHCAT master	CI511-ETHCAT / CI512-ETHCAT	●	●	-	remote I/O	●	●
CS31 bus	Onboard COM1 interface	DC505-CS31 / CI592-CS31	●	●	-	remote I/O	●	-
		CI590-CS31-HA	●	-	-	HA	●	-
	CM574-RS	DC505-CS31 / CI592-CS31	●	●	-	remote I/O	●	-
		CI590-CS31-HA	●	-	-	HA	●	-

(1) In preparation

(2) Only support of the I/O from the CI58x module, no addition S500 I/O supported today

## AC500

### Ordering data

#### I/O modules

- Hot swap capable when mounted on hot swap terminal unit
- For central extension of the AC500 or AC500-eCo CPUs
- For decentralized extension in combination with communication interface modules on CS31, PROFINET IO, EtherCAT, Modbus TCP, PROFIBUS DP, CANopen modules
- DC and AC: Channels can be configured individually as inputs or outputs
- Plug-in electronic modules, terminal unit required (refer to table below).

#### Digital I/O

Number of	Input signal	Output type	Output signal	Terminal units Screw / Spring	Type	Order code	Price	Weight (1 pce) kg
<b>DI/DO/DC</b>								
32 / - / -	24 V DC	-	-	TU515 / TU516	DI524	1SAP240000R0001		0.200
- / - / 16	24 V DC	Transistor	24 V DC, 0.5 A	TU515 / TU516	DC522	1SAP240600R0001		0.200
- / - / 24	24 V DC	Transistor	24 V DC, 0.5 A	TU515 / TU516	DC523	1SAP240500R0001		0.200
16 / - / 16	24 V DC	Transistor	24 V DC, 0.5 A	TU515 / TU516	DC532	1SAP240100R0001		0.200
8 / 8 / -	24 V DC	Relay	230 V AC, 3 A (2)	TU531 / TU532	DX522	1SAP245200R0001		0.300
8 / 4 / -	230 V AC	Relay	230 V AC, 3 A (2)	TU531 / TU532	DX531	1SAP245000R0001		0.300
- / 32 / -	-	Transistor	24 V DC, 0.5 A	TU515 / TU516	DO524	1SAP240700R0001		0.200
- / 8 / -	-	Transistor	24 V DC, 2 A	TU541 / TU542	DO526	1SAP240800R0001		0.200

(2) Relay outputs, changeover contacts.



DO524

## AC500

### Ordering data

#### Analog I/O

Number of	Input signal	Output signal	Terminal units Screw / Spring	Type	Order code	Price	Weight (1 pce) kg
<b>AI/AO/AC</b>							
16 / 0 / 0	0...10 V, ±10 V	–	TU515 / TU516	AI523	1SAP250300R0001		0.200
4 / 4 / 0	0/4...20 mA, PT100, PT1000, Ni1000	±10 V	TU515 / TU516	AX521	1SAP250100R0001		0.200
0 / 0 / 8 (max. 4 current outputs)		0/4...20 mA	TU515 / TU516	AC522	1SAP250500R0001		0.200
8 / 8 / 0 (max. 4 current outputs)			TU515 / TU516	AX522	1SAP250000R0001		0.200
0 / 16 / 0 (max. 8 current outputs)	–		TU515 / TU516	AO523	1SAP250200R0001		0.200
8 / 0 / 0	0...5 V, 0...10 V, ±50 mV, ±500 mV, 1 V, ±5 V, ±10 V, 0/4...20 mA, ±20 mA, PT100, PT1000, Ni1000, Cu50, 0...50 kΩ, S, T, N, K, J	–	TU515 / TU516	AI531	1SAP250600R0001		0.200

#### Analog/digital mixed I/O

Number of	Input signal	Output type	Output signal	Terminal unit Screw / Spring	Type	Order code	Price	Weight (1 pce) kg
<b>AI/AO/DI/DO/DC</b>								
4 / 2 / 16 / - / 8	24 V DC/0...10 V, -10...+10 V, 0...20 mA, 4...20 mA, PT100, PT1000, Ni100, Ni1000	Transistor	24 V DC, 0.5 A / -10...+10 V, 0...20 mA, 4...20 mA	TU515 / TU516	DA501	1SAP250700R0001		0.200
4 / 2 / - / 16 / 8				TU515 / TU516	DA502	1SAP250800R0001		0.200

#### Function module

- Not hot swap capable

Functionality	Number of	Input signal	Output type	Output signal	Terminal units Screw / Spring	Type	Order code	Price	Weight (1 pce) kg
<b>DI/DO/DC</b>									
Encoder and PWM module	2 / - / 8	24 V DC and 2 encoder inputs A/B/C differential	2 PWM outputs	24 V DC, 0.1 A	TU515 / TU516	CD522	1SAP260300R0001		0.125

#### Fast I/O module for direct mounting on the terminal base of the AC500 CPU

Functionality	Number of	Input signal	Output type	Output signal	Terminal unit	Type	Order code	Price	Weight (1 pce) kg
<b>DI/DO/DC</b>									
Interrupt I/O and fast counter	- / - / 8	24 V DC	Transistor	24 V DC, 0.5 A	N/A (2)	DC541-CM (1)	1SAP270000R0001		0.100

(1) Function module, refer to table on page 130 for details. Terminal block for I/O signal connection included.

(2) Occupies a communication module slot.



AO523



AI531



DA501



DC522



DC541-CM



## AC500

### Ordering data

#### Communication interface modules

Number of AI/AO/DI/DO/DC	Input signal	Output type	Output signal	Terminal units Screw / Spring	Type	Order code	Price	Weight (1 pce) kg
<b>For CS31-Bus</b>								
- / - / 8 / - / 16	24 V DC	Transistor	24 V DC, 0.5 A	TU551-CS31 / TU552-CS31	DC551-CS31	1SAP220500R0001		0.200
- / - / - / - / 16	24 V DC	Transistor	24 V DC, 0.5 A	TU551-CS31 / TU552-CS31	CI590-CS31-HA	1SAP221100R0001		0.200
4 / 2 / 8 / - / 8	24 V DC/ 0...10 V, -10...+10 V, 0...20 mA, 4...20 mA, PT100, PT1000, Ni100, Ni1000	Transistor	24 V DC, 0.5 A/ -10...+10 V, 0...20 mA, 4...20 mA	TU551-CS31 / TU552-CS31	CI592-CS31	1SAP221200R0001		0.200
<b>For PROFIBUS-DP</b>								
4 / 2 / 8 / 8 / -	24 V DC/ 0...10 V, -10...+10 V, 0...20 mA, 4...20 mA, PT100, PT1000, Ni100, Ni1000	Transistor	24 V DC, 0.5 A/ -10...+10 V, 0...20 mA, 4...20 mA (1)	TU509/TU510/ TU517/TU518	CI541-DP	1SAP224100R0001		0.200
- / - / 8 / 8 / 8	24 V DC	Transistor	24 V DC, 0.5 A	TU509/TU510/ TU517/TU518	CI542-DP	1SAP224200R0001		0.200
<b>For CANopen</b>								
4 / 2 / 8 / 8 / -	24 V DC/ 0...10 V, -10...+10 V, 0...20 mA, 4...20 mA, PT100, PT1000, Ni100, Ni1000	Transistor	24 V DC, 0.5 A/ -10...+10 V, 0...20 mA, 4...20 mA	TU509/TU510/ TU517/TU518	CI581-CN	1SAP228100R0001		0.200
- / - / 8 / 8 / 8	24 V DC	Transistor	24 V DC, 0.5 A	TU509/TU510/ TU517/TU518	CI582-CN	1SAP228200R0001		0.200
<b>For Ethernet-based protocol - EtherCAT</b>								
4 / 2 / 8 / 8 / -	24 V DC/ 0...10 V, -10...+10 V, 0...20 mA, 4...20 mA, PT100, PT1000, Ni100, Ni1000	Transistor	24 V DC, 0.5 A / -10...+10 V, 0...20 mA, 4...20 mA	TU507-ETH / TU508-ETH	CI511-ETHCAT	1SAP220900R0001		0.200
- / - / 8 / 8 / 8	24 V DC	Transistor	24 V DC, 0.5 A	TU507-ETH / TU508-ETH	CI512-ETHCAT	1SAP221000R0001		0.200
<b>For Ethernet-based protocol - PROFINET IO RT</b>								
4/2/8/8/-	24 V DC/ 0...10 V, -10...+10 V, 0...20 mA, 4...20 mA, PT100, PT1000, Ni100, Ni1000	Transistor	24 V DC, 0.5 A/ -10...+10 V, 0...20 mA, 4...20 mA	TU507-ETH / TU508-ETH	CI501-PNIO	1SAP220600R0001		0.200
- / - / 8 / 8 / 8	24 V DC	Transistor	24 V DC, 0.5 A	TU507-ETH / TU508-ETH	CI502-PNIO	1SAP220700R0001		0.200
<b>For Ethernet-based protocol - Modbus TCP</b>								
4/2/8/8/-	24 V DC/ 0...10 V, -10...+10 V, 0...20 mA, 4...20 mA, PT100, PT1000, Ni100, Ni1000	Transistor	24 V DC, 0.5 A/ -10...+10 V, 0...20 mA, 4...20 mA	TU507-ETH / TU508-ETH	CI521-MODTCP	1SAP222100R0001		0.200
- / - / 8 / 8 / 8	24 V DC	Transistor	24 V DC, 0.5 A	TU507-ETH / TU508-ETH	CI522-MODTCP	1SAP222200R0001		0.200



CI541-DP



CI581-CN



CI511-ETHCAT



CI501-PNIO



CI521-MODTCP

## AC500

### Ordering data

#### Communication interface modules

From	To	Output signal	Terminal units	Type	Order code	Price	Weight (1 pce) kg
<b>Gateway on Ethernet-based protocol - PROFINET IO RT</b>							
PROFINET IO	-	3 x RS232/422/485 ASCII serial interfaces	TU520-ETH	CI504-PNIO	1SAP221300R0001		0.200
PROFINET IO	1x CAN 2A/2B or CANopen Master	2 x RS232/422/485 ASCII serial interfaces	TU520-ETH	CI506-PNIO	1SAP221500R0001		0.200



CI504-PNIO

#### Hot swap terminal units

For loadless hot swapping of digital and analog extension modules, when used in configurations with communication interface modules or AC500 CPU supporting hot swap. Hot swapping of attached extension module mounted on hot swap terminal unit is supported by AC500 V3 CPU modules as of PM5630-2ETH, AC500 V2 CPU modules as of PM585-ETH, CI501-PNIO, CI502-PNIO, CI541-DP, CI542-DP, CI521-MODTCP and CI522-MODTCP. AC500-S safety I/O modules cannot be used in configurations containing hot swap terminal units. Mixed configurations of hot swap terminal units with normal terminal units for digital and analog extension modules are possible. In the installation hot swap terminal units can be identified by the word Hot Swap and a white frame around the connection terminal area.

For	Supply	Connection type	Type	Order code	Price	Weight (1 pce) kg
I/O modules - for Hot Swap (1)	24 V DC	Spring	TU516-H	1SAP215000R0001		0.300
I/O modules AC / relay - for Hot Swap (1)	230 V AC	Spring	TU532-H	1SAP215100R0001		0.300
High current I/O module - for Hot Swap (1)	24 V DC	Spring	TU542-H	1SAP215200R0001		0.300

(1) I/O module as of index F0 needed for Hot Swap



TU516-H

## AC500

### Ordering data

#### Terminal units

For digital and analog extension modules and interface modules. Please note: for modules with relay outputs, terminal units for 230 V AC (TU531 / TU532) are required.

For	Supply	Connection type	Type	Order code	Price	Weight (1 pce) kg
Ethernet communication interface modules	24 V DC	Screw	TU507-ETH	1SAP214200R0001		0.300
		Spring	TU508-ETH	1SAP214000R0001		0.300
Ethernet gateway modules	24 V DC	Spring	TU520-ETH	1SAP214400R0001		0.300
CANopen / PROFIBUS DP (1) communication interface modules	24 V DC	Screw	TU517	1SAP211400R0001		0.300
		Spring	TU518	1SAP211200R0001		0.300
PROFIBUS DP / CANopen communication interface modules	24 V DC	Screw	TU509	1SAP211000R0001		0.300
		Spring	TU510	1SAP210800R0001		0.300
I/O modules	24 V DC	Screw	TU515	1SAP212200R0001		0.300
		Spring	TU516	1SAP212000R0001		0.300
I/O modules AC / relay	230 V AC	Screw	TU531	1SAP217200R0001		0.300
		Spring	TU532	1SAP217000R0001		0.300
High current I/O module (DO526)	24 V DC	Screw	TU541	1SAP213000R0001		0.300
	24 V DC	Spring	TU542	1SAP213200R0001		0.300
CS31 interface modules	24 V DC	Screw	TU551-CS31	1SAP210600R0001		0.300
		Spring	TU552-CS31	1SAP210400R0001		0.300

(1) TU517/TU518 Terminal units can also be used with PROFIBUS DP CI54x modules up to 1 Mbit/s.



TU515



TU520-ETH



TU510



TU518



TU508-ETH

## AC500

### Ordering data

#### Terminal units compatibility

Type	For I/O modules			For communication interface modules				
	TU515	TU541	TU531	TU507-ETH	TU509	TU517	TU520-ETH	TU551-CS31
	TU516	TU542	TU532	TU508-ETH	TU510	TU518		TU552-CS31
	TU516-H	TU542-H	TU532-H					
DA501	•							
DA502	•							
DC522	•							
DC523	•							
DC532	•							
DI524	•							
DX522			•					
DX531			•					
DO524	•							
DO526		•						
CD522	• (2)							
AC522	•							
AI523	•							
AI531	•							
AO523	•							
AX521	•							
AX522	•							
DC551-CS31								•
CI590-CS31-HA								•
CI592-CS31								•
CI501-PNIO				•				
CI502-PNIO				•				
CI504-PNIO							•	
CI506-PNIO							•	
CI511-ETHCAT				•				
CI512-ETHCAT				•				
CI521-MODTCP				•				
CI522-MODTCP				•				
CI541-DP					•			• (1)
CI542-DP					•			• (1)
CI581-CN					•			•
CI582-CN					•			•

(1) Can be used with baud rate up to 1 Mbaud.

(2) CD522 cannot be used on TU516-H.

## AC500

### Ordering data

For	Description	Type	Order code	Price	Weight (1 pce) kg
AC500 CPUs	Memory card (2 GB) - not to be used for future project	MC502 (1)	1SAP180100R0001		0.020
	Memory card for high requirements (2 GB), for long term use e.g. data login or use in eXtreme Conditions.	MC5141 (2)	1SAP180100R0041		0.020
	Micro memory card for standard usage. 8 GB Micro memory card with adapter. (3)	MC5102 (2)	1SAP180100R0002		0.020
	Lithium battery for data buffering	TA521	1SAP180300R0001		0.100
I/O modules	Pluggable marker holder for I/O modules, packing unit incl. 10 pcs. Template available in the AC500 online help	TA523	1SAP180500R0001		0.300
AC500 CPU's, interface module, communication module and I/O modules	White labels, packing unit incl. 10 pcs.	TA525	1SAP180700R0001		0.100
Terminal base	Communication Module, blind cap	TA524	1SAP180600R0001		0.120
CPU terminal base	Accessories for screw mounting, packing unit includes 10 pcs	TA526	1SAP180800R0001		0.200
	5-pole power plug for AC500. Spare part. Can be plugged to CPU terminal base TB5x1. Packing unit includes 5 pcs	TA527	1SAP181100R0001		0.200
	9-pole COM1 plug for AC500. Spare part. Can be plugged to CPU terminal base TB5x1 or on TU520-ETH. Packing unit includes 5 pcs	TA528	1SAP181200R0001		0.200
Communication modules	9-pole spring plug for CM574-RS/RCOM. Spare part. Packing unit includes 10 pcs	TA532	1SAP182000R0001		
	5-pole spring plug for CM575-DN/CM578-CN. Spare part. Packing unit includes 5 pcs	TA533	1SAP182100R0001		
	2x5-pole spring plug for CM588-CN and CM598-CN. Spare part. Packing unit includes 5 pcs.	TA534	1SAP182200R0001		
	10-pole spring plug for DC541-CM. Spare part. Packing unit includes 10 pcs.	TA536	1SAP183100R0001		
AC500 V2 training case	PM585-ETH + TB521-ETH + CM579-PNIO + DA501 + CI502-PNIO + CP6607 + Case + 115-230 V AC power supply + Ethernet cables + demo program + memory card + simulation stand	TA515-CASE	1SAP182400R0002		7.000
AC500 V3 training case	PM5630-2ETH + TB5620-2ETH + CM579-PNIO + DA501 + CI502-PNIO + CP6607 + Case + 115-230 V AC power supply + Ethernet cables + demo program + memory card + simulation stand	TA5450-CASE	1SAP187700R0001		7.000
AC500 CPUs PM595	Protective cap, spare-parts. Packing unit includes 3 pcs	TA540	1SAP182600R0001		0.200
	Lithium battery for real-time-clock buffering	TA541	1SAP182700R0001		0.030
	Accessories for screw-mounting. Packing unit includes 20 pcs	TA543	1SAP182800R0001		0.100

(1) Product is transferred to life cycle phase classic in 2021.

(2) In preparation

(3) When used with AC500-eCo V2 CPU, the usable capacity is limited to 4 GB. For temporary use, e.g. firmware- or project download. Not to be used during vibration or shock.



MC502



AC500 training case  
CPU, I/Os, HMI

# AC500

## Technical data

### AC500 CPUs

Type	PM572	PM573-ETH	PM582	PM583-ETH	PM585-ETH
Supply voltage	24 V DC				
Current consumption on 24 V DC					
Min. (module alone)	0.050 A	0.110 A	0.050 A	0.110 A	0.150 A
Max. (all couplers and I/Os)	0.750 A	0.810 A	0.750 A	0.810 A	0.850 A
Type of processor	Freescale ARM Processor 32-bit				
Processor clock frequency	50 MHz		84 MHz		400 MHz
Total RAM memory	32 MB				64 MB
Total Flash memory	16 MB				32 MB
Total user program memory (2)	256 kB	2048 kB	928 kB	6144 kB	7680 kB
User program memory – Flash EPROM and RAM	128 kB	512 kB	512 kB	1024 kB	1024 kB
Integrated user data memory	128 kB thereof 12 kB saved	512 kB thereof 288 kB saved	416 kB thereof 288 kB saved	1024 kB thereof 288 kB saved	2560 kB thereof 1536 kB saved
User flash disk (data-storage, programm access or also external with FTP)	–				
Plug-in memory card	Depending on memory card used : no SD-HC card allowed, use MC5102 for standard usage or MC5141 for high requirements				
Web server's data for user RAM disk	–	1 024 kB	–	4 096 kB	4 096 kB
Data buffering	battery				
Real-time clock (with battery back-up)	●				
<b>Cycle time for 1 instruction (minimum)</b>					
Binary	0.06 μs	0.06 μs	0.05 μs	0.05 μs	0.004 μs
Word	0.09 μs	0.09 μs	0.06 μs	0.06 μs	0.008 μs
Floating-point	0.7 μs	0.7 μs	0.5 μs	0.5 μs	0.008 μs
<b>Max. number of centralized inputs/outputs</b>					
Max. number of extension modules on I/O bus	up to max. 10 (S500 and/or S500-eCo modules allowed)				
Digital	inputs/outputs 320/320				
Analog	inputs/outputs 160/160				
<b>Max. number of decentralized inputs/outputs</b>					
depends on the used standard fieldbus (1)					
<b>Program execution</b>					
Cyclical / Time controlled / Multi tasking	●/●/●				
User program protection by password	●				
<b>Internal interfaces</b>					
<b>COM1</b>					
RS232 / RS485 configurable	●				
Connection (on terminal bases or CPU module)	pluggable spring terminal block				
Programming, Modbus RTU, ASCII, CS31 master	●				
<b>COM2</b>					
RS232 / RS485 configurable	●				
Connection (on terminal bases or CPU module)	D-Sub 9 female				
Programming, Modbus RTU, ASCII	●				
<b>FieldBusPlug</b>					
Serial neutral interface	●				
Connection (on terminal bases)	M12 male, 5 pole				
Functions	programming cable UTF-21-FBP, slave communication depending on FieldBusPlug used (PROFIBUS DP, CANopen, DeviceNet)				
<b>Ethernet</b>					
Ethernet connection (on terminal bases)	–	RJ45	–	RJ45	RJ45
Ethernet functions: Programming, TCP/IP, UDP/IP, Modbus TCP, integrated Web server, IEC 60870-5-104 remote control protocol, MQTT, SNMP (simple Network Time Protocol), DHCP, FTP server HTTP, SMTP, PING	–	●	–	●	●
<b>Ethernet-based fieldbus</b>					
Ethernet connection (on CPU module)	–				
Downloadable protocols like: PROFINET IO RT Controller / EtherCAT Master	–				
<b>CPU display</b>					
Function	LC display and 8 function keys				
LEDs for various status display	Run, Stop, Error				
Timer/Counter	unlimited/unlimited				
<b>Approvals</b>					
See detailed page 272 or <a href="http://www.abb.com/plc">www.abb.com/plc</a>					

(1) e.g. CS31 fieldbus: up to 31 stations with up to 120 DI/ 120 DOs or up to 32 AIs / 32 AOs per station.

(2) Total user program memory: contains user program code, data and web server



# AC500

## Technical data

### AC500 CPUs

Type	PM590-ETH	PM591-ETH	PM591-2ETH	PM592-ETH	PM595-4ETH-F
Supply voltage	24 V DC				
Current consumption on 24 V DC					
Min. (module alone)	0.150 A	0.150 A	0.150 A	0.150 A	0.400 A
Max. (all couplers and I/Os)	0.850 A	0.850 A	0.850 A	0.850 A	1.2 A
Type of processor	Freescale ARM Processor 32-bit				
Processor clock frequency	400 MHz				1.3 GHz
Total RAM memory	64 MB				256 MB
Total Flash memory	32 MB				64 MB
Total user program memory (3)	13316 kB	17924 kB	17924 kB	17924 kB	64 MB
User program memory – Flash EPROM and RAM	2048 kB	4096 kB	4096 kB	4096 kB	16384 kB
Integrated user data memory	3072 kB thereof 1536 kB saved	5632 kB thereof 1536 kB saved	5632 kB thereof 1536 kB saved	5632 kB thereof 1536 kB saved	16384 kB thereof 3072 kB saved
User flash disk (data-storage, programm access or also external with FTP)	-			Yes, 4 GB Flash non removable	
Plug-in memory card	Depending on memory card used: no SD-HC card allowed, use MC5102 for standard usage or MC5141 for high requirements				
Web server's data for user RAM disk	8 MB				32 MB
Data buffering	battery				
Real-time clock (with battery back-up)	●				
<b>Cycle time for 1 instruction (minimum)</b>					
Binary	0.002 μs	0.002 μs	0.002 μs	0.002 μs	0.0006 μs
Word	0.004 μs	0.004 μs	0.004 μs	0.004 μs	0.001 μs
Floating-point	0.004 μs	0.004 μs	0.004 μs	0.004 μs	0.001 μs
<b>Max. number of centralized inputs/outputs</b>					
Max. number of extension modules on I/O bus	up to max. 10 (S500 and/or S500-eCo modules allowed)				
Digital inputs/outputs	320/320				
Analog inputs/outputs	160/160				
<b>Max. number of decentralized inputs/outputs</b>	depends on the used standard fieldbus (1)				
<b>Program execution</b>					
Cyclical / Time controlled / Multi tasking	●/●/●				
User program protection by password	●				
<b>Internal interfaces</b>					
<b>COM1</b>					
RS232 / RS485 configurable	●				
Connection (on terminal bases or CPU module)	pluggable spring terminal block, use TK502 cable in accessory				
Programming, Modbus RTU, ASCII, CS31 master	●				
<b>COM2</b>					
RS232 / RS485 configurable	●				
Connection (on terminal bases or CPU module)	D-Sub 9 female, use TK501 cable in accessory				
Programming, Modbus RTU, ASCII	●				
<b>FieldBusPlug</b>					
Serial neutral interface	●				-
Connection (on terminal bases)	M12 male, 5 pole				-
Functions	programming cable UTF-21-FBP, slave communication depending on FieldBusPlug used (PROFIBUS DP, CANopen, DeviceNet)				-
<b>Ethernet</b>					
Ethernet connection (on terminal bases)	RJ45	RJ45	2 x RJ45	RJ45	2 x RJ45
Ethernet functions: Programming, TCP/IP, UDP/IP, Modbus TCP, integrated Web server, IEC 60870-5-104 remote control protocol, MQTT, SNMP (simple Network Time Protocol), DHCP, FTP server HTTP, SMTP, PING	●	●	●	●	●
<b>Ethernet-based fieldbus</b>					
Ethernet connection (on CPU module)	-				4 x RJ45 (2 x interfaces with 2-port switch)
Downloadable protocols like: PROFINET IO RT Controller / EtherCAT Master or Ethernet like Modbus TCP	-				●
<b>CPU display</b>	LC display and 8 function keys				
Function	RUN / STOP, status, diagnosis				RUN / STOP, status, diagnosis, RESET
LEDs for various status display	Run, Stop, Error				●
Timer/Counter	unlimited/unlimited				
<b>Approvals</b>	See detailed page 272 or <a href="http://www.abb.com/plc">www.abb.com/plc</a>				

(1) e.g. CS31 fieldbus: up to 31 stations with up to 120 DIs / 120 DOs or up to 32 AIs / 32 AOs per station. (2) Availability on demand

(3) Total user program memory: contains user program code, data and web server

# AC500

## Technical data

### AC500 V3 CPUs

Type	PM5630-2ETH	PM5650-2ETH	PM5670-2ETH	PM5675-2ETH
Supply voltage	24 V DC			
Current consumption on 24 V DC				
Min. typ. (module alone)	0.110 A	0.120 A	0.140 A	
Max. typ. (all couplers and I/Os)	0.850 A	0.900 A	0.950 A	
Type of processor	TI ARM Cortex-A9 32-bit-RISC			
Processor clock frequency	300 MHz	600 MHz	1 GHz	1 GHz
Total RAM memory	128 MB	256 MB	512 MB	512 MB
Total Flash memory	128 MB	512 MB	1024 MB	1024 MB
Total user program memory (4)	8 MB	80 MB		160 MB
Thereof User program code and data (dynamically allocated)	2 MB (3)	8 MB (3)	32 MB (3)	32 MB (3)
Thereof User web server Data max.	6 MB	72 MB	128 MB	128 MB
User data memory saved	256 kB	256 kB	1.5 MB	1.5 MB
Thereof VAR Retain persistent	128 kB	128 kB	1024 kB	1024 kB
Thereof %M memory (e.g. Modbus register memory)	128 kB	128 kB	512 kB	512 kB
User flash disk (data-storage, programm access or also external with FTP)				8 GB Flash non removable
Plug-in memory card	Depending on memory card used: use MC5102 for standard usage or MC5141 for high requirements, MC502 not for future project			
Data buffering	battery			
Real-time clock (with battery back-up)	●			
<b>Cycle time for 1 instruction (minimum)</b>				
Binary	0.02 µs	0.01 µs	0.002 µs	
Word	0.03 µs	0.01 µs	0.002 µs	
Floating-point	0.12 µs	0.01 µs	0.002 µs	
Program execution				
Cyclical	●			
Minimun cycle time configurable for cyclical task	1 ms	1 ms	0.5 ms	
Time controlled	●			
Multi tasking	●			
User program protection by password	●			
Motion control with EtherCAT or CAN sync onboard and PLCopen library PS5611-MC(2)				
Min. EtherCAT master cycle time	2 ms	1 ms	0.5 ms	
Number of synchronized axis (5) in 1 ms	-	8	16	
Number of synchronized axis (5) in 2 ms	4	16	32	
Number of synchronized axis (5) in 4 ms	8	32	64	
<b>Communication modules and terminal bases supported</b>				
Max. number of communication modules on terminal base TB				
TB5600-2ETH	0 slot	0 slot	0 slot	
TB5610-2ETH	1 slot	1 slot	1 slot	
TB5620-2ETH	2 slots	2 slots	2 slots	
TB5640-2ETH	-	4 slots	4 slots	
TB5660-2ETH	-	-	6 slots	
Type of safety module supported				
SM560-S - safety module	●			
SM560-S-FD-1 - safety module with F-Device functionality for 1 PROFIsafe network	● (1)			
SM560-S -FD-4 - safety module with F-Device functionality for 1 PROFIsafe network	● (1)			
Type of communication module supported				
Max. number of variables allowed for each communication module supported				
Input variables	4 kB		5 kB	
Output variables	4 kB		5 kB	
CM574-RS/RCOM - serial interface	-			
CM582-DP - PROFIBUS DP V0/V1 Slave	● (1)			
CM592-DP - PROFIBUS DP V0/V1 Master	● (1)			
CM579-ETHCAT - Master	●			
CM579-PNIO - PROFINET IO RT controller	●			
CM589-PNIO - PROFINET IO RT device	● (1)			
CM589-PNIO-4 - PROFINET IO RT with 4 devices	● (1)			
CM597-ETH - Ethernet interface	-			
CM588-CN - CAN, CANopen Slave	-			
CM598-CN - CAN, CANopen Master	● only CAN 2A/2B today			

(1) In preparation (2) Recommendation

(3) Memory size of V2 versus V3 CPUs is not comparable. Projects have a different and separate User Program code and Data memory calculation in Automation Builder 2.4.0 version or later. System, configuration and web server parts are not counted anymore. This results in typically about 50 % lower memory usage compared to V2, and even lower memory usage compared to V3 projects compiled in Automation Builder 2.3.0 or before.

(4) Total user program memory: contains user program code, data (dynamically allocated), web server memory and infrastructure (5) + 1 e.g. for virtual axis

# AC500

## Technical data

### AC500 V3 CPUs

Type	PM5630-2ETH	PM5650-2ETH	PM5670-2ETH	PM5675-2ETH
<b>Max. number of centralized inputs/outputs</b>				
Max. number of extension modules on I/O bus	up to max. 10 (S500 and/or S500-eCo I/O modules allowed)			
Digital inputs/outputs	320/320			
Analog inputs/outputs	160/160			
<b>Max. number of decentralized inputs/outputs</b>	depends on the used standard fieldbus (1)			
<b>Internal interfaces for communication</b>				
<b>COM1</b>				
RS232 / RS485 configurable	●			
Connection (on terminal bases or CPU module)	pluggable spring terminal block			
Modbus RTU Master/Slave, ASCII	●			
<b>CANopen</b>				
Serial interface	CAN serial interface			
Connection (on terminal bases)	Pluggable spring terminal block, 2x 5 poles			
Functions	CANopen® Master communication, CAN 2A/2B, J1939 protocol, CAN sync			
Max. number of variables allowed				
Input variables	2 kB	4 kB	5 kB	
Output variables	2 kB	4 kB	5 kB	
<b>Ethernet</b>				
Ethernet connection (on terminal bases)	2x independent Ethernet interfaces for several uses 2x RJ45 with 2x separated interfaces and MAC-Address, could be used as 2-port switch with 1x interface			
<b>Ethernet functions (4):</b>				
Ethernet Switch on ETH1 / ETH2	●			
Online Access, ICMP (Ping), DHCP, programming	●			
Nb of parallel connections	6	8	12	
IP configuration protocol	●			
UDP data exchange, Network variables	● / ●			
HTTP / HTTPs (integrated web server)	●			
Nb of parallel connections	4	8	12	
Web Visu for data visualisation on web server HTML5	●			
SNTP (Time synchronization) Server / Client	● / ●			
FTP / FTPs server	●			
Nb of parallel connections	2	4	4	
SMTP client	●			
Socket programming	●			
<b>Modbus TCP Client / Server</b>				
Nr of Modbus clients ModMast in parallel on a CPU Master (Server)	30	50	120	
Nr of Modbus server in parallel (for SCADA access e.g.)	15	25	50	
<b>IEC 60870-5-104 remote control protocol - Support 2nd connection</b>				
Nr of free tags + additional license for extension (2)	1000	5000	10000	
Control Station - Nb connections	5	10	20	
Sub-Station - Nb connections	5	10	20	
<b>OPC UA Server (Micro Embedded Device Server) with security</b>				
Nr of free tags + additional license for extension (2)	3000	10000	30000	
Nr of Connections	10	20	50	
min sampling rate (limit)	500 ms	100 ms	50 ms	
<b>OPC DA Server AE</b>				
Nr of Connections	8	8	8	
<b>Ethernet-based fieldbus protocols on onboard Ethernet interface (4)</b>				
Downloadable protocols (licensed feature with runtime license per CPU):	The number of allowed variables is depending on the protocol used available on one Ethernet interface, the other interface can be sometimes used as switch			
<b>Ethernet/IP Scanner communication</b>	● (2)(3)	● (2)(3)	● (2)(3)	
<b>Ethernet/IP Adapter communication</b>	● (2)(3)	● (2)(3)	● (2)(3)	
Maximum allowed number of input/output variables for the onboard fieldbus protocol	0.5 kB / 0.5 kB	0.5 kB / 0.5 kB	0.5 kB / 0.5 kB	
<b>IEC 61850 - MMS server Edition 1 / GOOSE communication</b>	● / ● (3)	● / ● (3)	● / ● (3)	
Maximum number of allowed data attributes in variables list	1000	2000	5000	
<b>KNX - Building communication</b>	● (3)	● (3)	● (3)	
Maximum number of allowed Objects variables on the interface	1000	1000	1000	
<b>BACnet-BC - Infrastructure communication</b>	● (3)	● (3)	● (3)	
Maximum number of allowed Objects variables on the interface	1000	2000	5000	
<b>CPU display</b>				
Function	LC display and 8 function keys			
LEDs for various status display	RUN / STOP, status, diagnosis, settings			
Timer/Counter	●			
	unlimited/unlimited			
<b>Approvals</b>	See detailed page 272 or <a href="http://www.abb.com/plc">www.abb.com/plc</a>			

(1) e.g. CANopen fieldbus: up to 127 stations with I/O from CI module only per station.

(2) In preparation

(3) Feature is licensed, runtime license per CPU.

(4) Using parallel protocols on the same and/or different port reduces the bandwidth and the CPU performance

# AC500

## Technical data

### Digital S500 I/O modules

Type	DI524	DC522	DC523	DC532
<b>Number of channels per module</b>				
Digital				
inputs	32	–	–	16
outputs	–	–	–	–
Configurable channels DC (configurable as inputs or outputs)	–	16	24	16
<b>Additional configuration of channels as</b>				
Fast counter	configuration of max. 2 channels per module, operating modes see table on page 147			
Occupies max. 1 DO or DC when used as counter	–	●	●	●
Connection via terminal unit	●	●	●	●
<b>Digital inputs</b>				
Input signal voltage	24 V DC			
Input characteristic acc. to EN 61132-2	Type 1			
0 signal	-3...+5 V DC			
Undefined signal state	5...15 V DC			
1 signal	15...30 V DC			
Input time delay (0 -> 1 or 1 -> 0)	8 ms typically, configurable from 0.1 up to 32 ms			
<b>Input current per channel</b>				
At input voltage	24 V DC 5 mA typically			
	5 V DC > 1 mA			
	15 V DC > 5 mA			
	30 V DC < 8 mA			
<b>Digital outputs</b>				
Transistor outputs 24 V DC, 0.5 A	–	●	●	●
Readback of output	–	●	●	●
Switching of load 24 V	–	●	●	●
Output voltage at signal state 1	–	process voltage UP minus 0.8 V		
<b>Output current</b>				
Nominal current per channel	–	0.5 A		
Maximum (total current of all channels)	–	8 A		
Residual current at signal state 0	–	< 0.5 mA		
Demagnetization when switching off inductive loads	–	by internal varistors		
<b>Switching frequency</b>				
For inductive load	–	0.5 Hz max.		
For lamp load	–	11 Hz max. at max. 5 W		
Short-circuit / overload proofness	–	●	●	●
Overload indication (I > 0.7 A)	–	after approx. 100 ms		
Output current limiting	–	yes, with automatic reclosure		
Proofness against reverse feeding of 24 V signals	–	●	●	●
<b>Process voltage UP</b>				
Nominal voltage	24 V DC			
Current consumption on UP				
Min. (module alone)	0.150 A	0.100 A	0.150 A	
Max. (min. + loads)	0.150 A	0.100 A + load	0.150 A + load	
Reverse polarity protection	●	●	●	●
Fuse for process voltage UP	10 A fast acting fuse			
Connections for sensor voltage supply. Terminal 24 V and 0 V for each connection. Permitted load for each group of 4 or 8 connections: 0.5 A	–	8	4	–
Short-circuit and overload proof 24 V DC sensor supply voltage	–	●	●	–
<b>Maximum cable length for connected process signals</b>				
Cable	shielded	1000 m		
	unshielded	600 m		
<b>Potential isolation</b>				
Per module		●	●	●
Between channels	input	–	–	–
	output	–	–	–
Voltage supply for the module	internally via extension bus interface (I/O bus)			
Fieldbus connection	via AC500 CPU or all communication interface modules			
Address setting	automatically (internal)			

# AC500

## Technical data

### Digital S500 I/O modules

Type		DX522	DX531	DO524	DO526
<b>Number of channels per module</b>					
Digital	inputs	8	8	–	–
	outputs	8 relays	4 relays	32	8
Configurable channels DC (configurable as inputs or outputs)		–	–	–	–
<b>Additional configuration of channels as</b>					
Fast counter		configuration of max. 2 channels per module, operating modes see page 147	–	–	–
Occupies max. 1 DO or DC when used as counter		–	–	–	–
Connection via terminal unit		●	●	●	●
<b>Digital inputs</b>					
Input signal voltage		24 V DC	230 V AC or 120 V AC	–	–
Frequency range		–	47...63 Hz	–	–
Input characteristic acc. to EN 61132-2		Type 1	Type 2	–	–
0 signal		-3...+5 V DC	0...40 V AC	–	–
Undefined signal state		5...15 V DC	> 40 V AC...< 74 V AC	–	–
1 signal		15...30 V DC	74...265 V AC	–	–
Input time delay (0 -> 1 or 1 -> 0)		8 ms typically, configurable from 0.1 up to 32 ms	20 ms typically	–	–
<b>Input current per channel</b>					
At input voltage		24 V DC	5 mA typically	–	–
		5 V DC	> 1 mA	–	–
		15 V DC	> 5 mA	–	–
		30 V DC	< 8 mA	–	–
		40 V AC	–	< 5 mA	–
		74 V AC	–	> 6 mA	–
<b>Digital outputs</b>					
Transistor outputs 24 V DC		–	–	●	●
Readback output		–	–	–	–
Relay outputs, supplied via process voltage UP, changeover contacts		●	●	–	–
Switching of load		24 V	●	●	●
		230 V	●	●	–
Output voltage at signal state 1		–	–	process voltage UP minus 0.8 V	process voltage UP minus 0.4 V
<b>Output current</b>					
Nominal current per channel		–	–	0.5 A	2 A
Maximum (total current of all channels)		–	–	8 A	16 A
Residual current at signal state 0		–	–	< 0.5 mA	< 0.1 mA
Demagnetization when switching off inductive loads		–	–	yes	yes
<b>Switching frequency</b>					
For inductive load		2 Hz	–	0.5 Hz max.	2 Hz max.
For lamp load		11 Hz max. at max. 5 W	–	–	11 Hz max. 48 W
Short-circuit / overload proofness		by external fuse / circuit breaker. 6 A gL/gG per channel	–	●	by external fuse 10A fast
Overload indication (I > 0.7 A)		–	–	after approx. 100 ms	–
Output current limiting		–	–	yes, with automatic reclosure	–
Resistance against reverse feeding of 24 V signals		–	–	●	●

## AC500

### Technical data

#### Digital S500 I/O modules

Type	DX522	DX531	DO524	DO526
<b>Contact rating</b>				
For resistive load, max.	3 A at 230 V AC 2 A at 24 V DC		–	–
For inductive load, max.	1.5 A at 230 V AC 1.5 A at 24 V DC		–	–
For lamp load	60 W at 230 V AC 10 W at 24 V DC		–	–
<b>Lifetime (switching cycles)</b>				
Mechanical lifetime	300 000		–	–
Lifetime under load (DC13)	300 000 at 24 V DC / 2 A 200 000 at 120 V AC / 2 A 100 000 at 230 V AC / 3 A		–	–
Spark suppression for inductive AC load	external measure depending on the switched load		–	–
Demagnetization for inductive DC load	external measure: free-wheeling diode connected in parallel to the load		–	–
<b>Process voltage UP</b>				
Nominal voltage	24 V DC			
<b>Current consumption on UP</b>				
Min. (module alone)	0.050 A	0.150 A	0.050 A	0.050 A
Max. (module + loads)	0.050 A + load	0.150 A + load	0.100 A + load	0.100 A + load
Reverse polarity protection	●	●	●	●
Fuse for process voltage UP	10 A			
<b>Maximum cable length for connected process signals</b>				
Cable	shielded	1000 m		
	unshielded	600 m		
<b>Potential isolation</b>				
Per module	●	●	●	●
Between the channels	input	–	● (per 2)	–
	output	●	●	–
Voltage supply for the module	internally via extension bus interface (I/O bus)			
Fieldbus connection	via AC500 CPU or all communication interface modules			
Address setting	automatically (internal)			



# AC500

## Technical data

### Analog S500 I/O modules

Type		AX521	AX522	AC522	AI523	AO523	AI531	
<b>Number of channels per module</b>								
Individual configuration, analog	inputs	4	8	–	16	–	8	
	outputs	4	8	–	–	16	–	
	configurable	–	–	8	–	–	–	
<b>Signal resolution for channel configuration</b>								
-10...+10 V		12 bits + sign						15 bits + sign
0...10 V		12 bits						15 bits
0...20 mA, 4...20 mA		12 bits						15 bits
Temperature: 0.1 °C		•	•	•	•	–	0.1/0.01	
<b>Monitoring configuration per channel</b>								
Plausibility monitoring		•	•	•	•	•	•	
Wire break & short-circuit monitoring		•	•	•	•	•	•	
<b>Analog Inputs AI</b>								
Signal configuration per AI		max. number per module and with regard to the configuration: AIs / Measuring points (depending on the use of 2/3-wire connection or differential input)						
-50...+50 mV, -500...+500 mV, -1...+1 V, -5...+5 V, 0...+5 V		–	–	–	–	–	8 / 8	
0...10 V		4 / 4	8 / 8	8 / 8	16 / 16	–	8 / 8	
-10...+10 V		4 / 4	8 / 8	8 / 8	16 / 16	–	8 / 8	
0...20 mA		4 / 4	8 / 8	8 / 8	16 / 16	–	8 / 8	
4...20 mA		4 / 4	8 / 8	8 / 8	16 / 16	–	8 / 8	
-20...+20 mA		–	–	–	–	–	8 / 8	
<b>Pt100</b>								
-50...+400 °C (2-wire)		4 / 4	8 / 8	8 / 8	16 / 16	–	8 / 8	
-50...+400 °C (3-wire), 2 channels		4 / 2	8 / 4	8 / 4	16 / 8	–	8 / 8	
-50...+400 °C (4-wire)		–	–	–	–	–	8 / 8	
-50...+70 °C (2-wire)		4 / 4	8 / 8	8 / 8	16 / 16	–	8 / 8	
-50...+70 °C (3-wire), 2 channels		4 / 2	8 / 4	8 / 4	16 / 8	–	8 / 8	
-50...+70 °C (4-wire)		–	–	–	–	–	8 / 8	
<b>Pt1000</b>								
-50...+400 °C (2-wire)		4 / 4	8 / 8	8 / 8	16 / 16	–	8 / 8	
-50...+400 °C (3-wire), 2 channels		4 / 2	8 / 4	8 / 4	16 / 8	–	8 / 8	
-50...+400 °C (4-wire)		–	–	–	–	–	8 / 8	
<b>Ni1000</b>								
-50...+150 °C (2-wire)		4 / 4	8 / 8	8 / 8	16 / 16	–	8 / 8	
-50...+150 °C (3-wire), 2 channels		4 / 2	8 / 4	8 / 4	16 / 8	–	8 / 8	
-50...+150 °C (4-wire)		–	–	–	–	–	8 / 8	
Cu50 -200...+200 °C		–	–	–	–	–	8 / 8	
Resistor 0...50 kΩ		–	–	–	–	–	8 / 8	
Thermocouples of types J, K, T, N, S		–	–	–	–	–	8 / 8	
0...10 V using differential inputs, 2 channels		4 / 2	8 / 4	8 / 4	16 / 8	–	8 / 8	
-10...+10 V using differential inputs, 2 channels		4 / 2	8 / 4	8 / 4	16 / 8	–	8 / 8	
Digital signals (digital input)		4 / 4	8 / 8	8 / 8	16 / 16	–	8 / 8	
Input resistance per channel		voltage: > 100 kΩ current: approx. 330 Ω					–	voltage: > 100 kΩ current: approx. 330 Ω
Time constant of the input filter		voltage: 100 μs current: 100 μs					–	voltage: 100 μs current: 100 μs
Conversion cycle		2 ms (for 8 AI + 8 AO), 1 s for Pt100/1000, Ni1000					–	1 ms 1 s for Pt100/1000, Ni1000
Overvoltage protection		•	•	•	•	–	•	

## AC500

### Technical data

#### Analog S500 I/O modules

Type		AX521	AX522	AC522	AI523	AO523	AI531	
<b>Data when using the AI as digital input</b>								
Input	time delay	8 ms typically, configurable from 0.1 up to 32 ms				–	8 ms typically, configurable from 0.1 up to 32 ms	
	signal voltage	24 V DC				–	24 V DC	
Signal	0	-30...+5 V				–	-30...+5 V	
	1	13...30 V				–	13...30 V	
<b>Analog outputs AO</b>								
Possible configuration per AO		Max. number of AOs per module and with regard to the configuration:						
	-10...+10 V	4	8	8	–	16	–	
	0...20 mA	4	4	4	–	8	–	
	4...20 mA	4	4	4	–	8	–	
Output	resistance (burden) when used as current output	0...500 Ω				–	0...500 Ω	–
	loading capability when used as voltage output	Max. ±10 mA				–	Max. ±10 mA	–
<b>Process voltage UP</b>								
Nominal voltage		24 V DC						
Current consumption on UP								
	Min. (module alone)	0.150 A					0.130 A	
	Max. (min. + loads)	0.150 A + load	0.150 A + load		–	0.150 A + load		
Reverse polarity protection		●	●	●	●	●	●	
Max. line length of the analog lines, conductor cross section > 0.14 mm <sup>2</sup>		100 m						
Conversion error of analog values caused by non-linearity, calibration errors ex works and the resolution in the nominal range		0.5 % typically, 1 % max.					Voltage: 0.1 % typically, current/resistor 0.3 % typically	
<b>Potential isolation</b>								
Per module		●	●	●	●	●	–	
Fieldbus connection		Via AC500 CPU or all communication interface modules						
Voltage supply for the module		Internally via extension bus interface (I/O bus)						

(1) Half can be used on current (the other half remains available).

## AC500

### Technical data

#### CD522 encoder module

The CD522 module offers accuracy and dynamic flexibility for a customized solution. It has two independent encoder inputs onboard and is easily configured using the Automation Builder software for 10 different operation modes and for frequencies up to 300 kHz. The CD522 module also integrates outputs for pulses and for PWM as well as normal inputs and outputs, depending on selected encoder mode.

Type		CD522
<b>Functionality</b>		
Digital inputs/outputs		24 V DC, dedicated inputs/outputs can be used for specific counting functions. All unused inputs/outputs can be used as input/output with standard specification.
	Input options	Catch/Touch operation, counter value stored in separate variable on external event (rising or falling) Set to preset counter register with predefined value Set to reset counter register
	End value output	Output set when predefined value is reached
	Reference point initialization (RPI) input for relative encoder initialization	●
High-speed counter/encoder		
Integrated counters	Counter characteristics	2 counters (24 V DC, 5 V DC, differential and 1 V <sub>pp</sub> sinus input)
	Counter mode	one 32 bits or two 16 bits
	Relative position encoder	X1, X2, X4
	Absolute SSI encoder	●
	Time frequency meter	●
	Frequency input	up to 300 kHz
PWM/pulse outputs		
Output mode specification	Number of outputs	2
	Push pull output	24 V DC, 100 mA max
	Current limitation	Thermal and overcurrent
PWM mode specification	Frequency	1...100 kHz
	Value	0...100 %
Pulse mode specification	Frequency	1...15 kHz
	Pulse emission	1...65535 pulses
	Number of pulses emitted indicator	0...100 %
Frequency mode specification	Frequency output	100 kHz
	Duty Cycle	Set to 50 %
<b>Number of channels per module</b>		
Digital	input	2
	output	2
Configurable channels DC (configurable as inputs or outputs)		8
<b>Additional configuration of channels as</b>		
Fast counter		Integrated 2 counter encoders
Connection via terminal unit		●
<b>Digital Inputs</b>		
Input	signal voltage	24 V DC
	time delay	8 ms typically configurable from 0.1 up to 32 ms
<b>Input current per channel</b>		
At input voltage	24 V DC	Typically 5 mA
	5 V DC	> 1 mA
	15 V DC	> 5 mA
	30 V DC	< 8 mA
<b>Digital outputs</b>		
Output voltage at signal state 1		UP – 0.8 V

## AC500

### Technical data

#### CD522 encoder module

Type	CD522	
<b>Output current</b>		
Nominal current per channel	0.5 A	
Maximum (total current of all channels)	8 A	
Residual current at signal state 0	< 0.5 mA	
Demagnetization when switching off inductive loads	By internal varistors	
<b>Switching frequency</b>		
For inductive load	Max. 0.5 Hz	
For lamp load	Max. 11 Hz with max. 5 W	
Short-circuit / Overload proofness	•	
Overload indication ( $I > 0.7 A$ )	After approx. 100 ms	
Output current limiting	•	
Proofness against reverse feeding of 24 V signals	•	
<b>Maximum cable length for connected process signals</b>		
Cable	shielded	1000 m
	unshielded	600 m
<b>Potential isolation</b>		
Per module	•	
<b>Technical data of the high-speed inputs</b>		
Number of channels per module	6	
Input type	24 V DC, 5 V DC / Differential / Sinus 1 Vpp	
Frequency	300 kHz	
<b>Technical data of the fast outputs</b>		
Number of channels	2	
Indication of the output signals	Brightness of the LED depends on the number of pulses emitted (0 % to 100 %) (pulse output mode only)	
<b>Output current</b>		
Rated value, per channel	100 mA	
Maximum value (all channels together, configurable outputs included)	8 A	
Leakage current with signal 0	< 0.5 mA	
Rated protection fuse on UP	10 A fast	
De-magnetization when inductive loads are switched off	with varistors integrated in the module	
Overload message ( $I > 0.1 \times A$ )	Yes, after ca. 100 ms	
Output current limitation	Yes, automatic reactivation after short-circuit/overload	
Resistance to feedback against 24 V signals	Yes	
<b>Process voltage UP</b>		
Nominal voltage	24 V DC	
Maximum ripple	5 %	
Current consumption on UP		
Min. (module alone)	0.070 A	
Max. (min. + loads)	0.070 A + load	
Reverse polarity protection	•	
Fuse for process voltage UP	10 A miniature fuse	

# AC500

## Technical data

### Analog/digital mixed I/O extension modules

For all modules: max cable length for connected process signals is 1000 m for shielded cable and 600 m for unshielded ones. For all Input modules, the signal resolution for channel configuration is: -10...+10 V: 12 bit + sign; 0...10 V, 0...20 mA, 4...20 mA: 12 bits.

Type	DA501	DA502
<b>Number of Channels per Module</b>		
Digital	inputs	16
	outputs	–
Analog	inputs	4
	outputs	2
Digital configurable channels DC (configurable as inputs or outputs)	8	8
<b>Additional configuration of channels as</b>		
Fast counter	Yes	
Occupies max. 1 DO or DC when used as counter	Configuration of max. 2 channels per module. Operating modes see table on page 147	
Connection via terminal unit TU 5xx	●	
<b>Digital inputs</b>		
Input	signal voltage	24 V DC
	characteristic acc. to EN 61132-2	Type 1
0 signal		-3...+5 V DC
Undefined signal state		5...15 V DC
1 signal		15...30 V DC
Residual ripple, range for	0 signal	-3...+5 V DC
	1 signal	15...30 V DC
Input time delay (0 -> 1 or 1 -> 0)	8 ms typically, configurable from 0.1 up to 32 ms	
<b>Digital outputs</b>		
Transistor outputs 24 V DC, 0.5 A	●	
Readback of output	●	
Outputs, supplied via process voltage UP	●	
Switching of 24 V load	●	
Output voltage at signal state 1	Process voltage UP - 0.8 V	
<b>Output current</b>		
Nominal current per channel	0.5 A	
Maximum (total current of all channels)	4 A	8 A
Residual current at signal state 0	< 0.5 mA	
Demagnetization when switching off inductive loads	By internal varistors	
<b>Analog inputs AI</b>		
	Max. number per module and with regard to the configuration: AIs / Measuring points	
Signal configuration per AI	●	
0...10 V / -10 ... +10 V	4 / 4	
0...20 mA / 4...20 mA	4 / 4	
RTD using 2/3 wire needs 1/2 channel(s)	4 / 2	
0...10 V using differential inputs, needs 2 channels	4 / 2	
-10...+10 V using differential inputs, needs 2 channels	4 / 2	
Digital signals (digital input)	4 / 4	
<b>Data when using the AI as digital input</b>		
Input	time delay	8 ms typically, configurable from 0.1 up to 32 ms
	signal voltage	24 V DC
<b>Outputs, single configurable as</b>		
Possible configuration per AO	●	
-10...+10 V	●	
0...20 mA / 4...20 mA	●	
Output resistance (load) when used as current output	0...500 Ω	
Output loading capability when used as voltage output	±10 mA max.	
<b>Potential isolation</b>		
Per module	●	
<b>Process voltage UP</b>		
Nominal voltage	24 V DC	
Maximum ripple	5 %	
Current consumption on UP		
Min. (module alone)	0.070 A	
Max. (min. + loads)	0.070 A + load	
Reverse polarity protection	●	
Fuse for process voltage UP	10 A fast	
<b>Approvals</b>	See detailed page 272 or <a href="http://www.abb.com/plc">www.abb.com/plc</a>	

## AC500

### Technical data

#### DC541-CM interrupt I/O and fast counter module

In the operating mode counter, the channels can be configured as follows:

Input, Output, 32-bit up/down counter (uses C0...C3) as a 32-bit counter without limit, 32-bit periodic counter as a 32-bit counter with a limit, limiter for a 32-bit counter (limit channel 0), 32-bit up counter (forward counter) with the frequencies 50 kHz, 5 kHz and 2.5 kHz, pulse-width modulation (PWM) with a resolution of 10 kHz, time and frequency measurement, frequency output.

Type	DC541-CM	
<b>Number of channels per module</b>		
Configurable channels DC (configurable as inputs or outputs)	8	
<b>Additional configuration of channels as</b>		
Fast counter	Yes	
Connection via CPU terminal base. Occupies one communication module slot	●	
<b>Digital inputs</b>		
Input	signal voltage	24 V DC
	characteristic acc. to EN 61132-2	Type 1
0 signal	-3...+5 V DC	
Undefined signal state	5...15 V DC	
1 signal	5...30 V DC	
Input time delay (0 -> 1 or 1 -> 0)	20 μs Clamp to clamp - 300 μs with interrupt task	
<b>Input current per channel</b>		
At input voltage	24 V DC	5 mA typically
	5 V DC	> 1 mA
	15 V DC	> 5 mA
	30 V DC	< 8 mA
<b>Digital outputs</b>		
Transistor outputs 24 V DC, 0.5 A	●	
Readback of output	●	
Switching of 24 V load	●	
Output voltage at signal state 1	Process voltage UP minus 0.8 V	
<b>Output current</b>		
Nominal current per channel	0.5 A	
Maximum (total current of all channels)	4 A	
Residual current at signal state 0	< 0.5 mA	
Demagnetization when switching off inductive loads	yes	
<b>Potential isolation</b>		
Per module	●	
Voltage supply for the module	Internally via backplane bus	



## AC500

### Technical data

#### DC541-CM interrupt I/O and fast counter module

##### Interrupt I/O table

Configuration as		Configuration for channel no.					Max. no. of channels for this function	Remarks and notes regarding possible alternative combinations of the remaining channels (a and b)
		Chan. 0	Chan. 1	Chan. 2	Chan. 3	Chan. 4-7		
<b>Mode 1: Interrupt functionality</b>								
Interrupt	Digital input	1	1	1	1	4	8	Each channel can be configured individually as interrupt input or output
	Digital output	1	1	1	1	4	8	
<b>Mode 2: Counting functionality</b>								
Digital I/Os PWM (1)	Digital input	1	1	1	1	4	8	Usual input
	Digital output	1	1	1	1	4	8	Usual output
	PWM, resolution 10 kHz	1	1	1	1	4	8	Outputs and pulsed signal with and adjustable on-off ratio

(1) Counter and fast counter data available on technical documentation.

## AC500

### Technical data

#### AC500 Condition Monitoring CMS: FM502-CMS

The FM502-CMS function module offers precision and dynamic flexibility for customized solutions in condition monitoring, precise measurement or fast data logging applications. It has 16 fast, precise and synchronized analog inputs with 50k Samples/s (SPS), 24bit ADC resolution, completed with encoder inputs (incremental or absolute) with counter and additional DI and DC inputs/outputs onboard. It is easily configured using the Automation Builder software and the special libraries. Overall it has 12 different operation modes. One FM502 function module can be placed on the right side of PM592-ETH CPU with a special function module terminal base TF5x1, to interface directly to the CPU. While long measurements can be flexibly configured, started and stopped, all inputs are available in the I/O Image of CPU for immediate use (measurement, protection, control, ...)

Type	FM502-CMS	
<b>Data storage</b>		
Fast user data memory of FM502	128 MB (ca. 33 million Samples: e.g 40 s record length on 16 channels at 50k SPS or 5.8 h record length on 16 channels at 100 SPS or 93 h on 1 channel at 100 SPS)	
File Format delivered to PM592 flash	WAV (compact binary) per channel, all channels in one *.zip w. time stamp	
<b>Analog inputs</b>		
Number of channels	16 (synchronous sampled)	
Resolution	24 bit ADC, stored in DINT in WAV file (4byte per value)	
Accuracy at +25 °C	< +/- 0.1 %	
Accuracy over operating temperature and vibration	< +/- 0.5 %	
Sample rate / Bandwidth (High, 0 dB)	50k SPS / 20 kHz to 100 SPS / 40 Hz (digitally downsampled, selectable per channel)	
Indication of the input signal	One bicolor LED per channel for configuration, measurement status, error messages	
<b>Input option:</b>	<b>IEPE (with Sensor supply current)</b>	<b>+ - 10 V</b>
Bandwidth low (- 3 dB)	digital < 0.1 Hz	digital < 0.1 Hz or DC (selectable)
Pass band high (- 3 dB)	analog > 90 kHz, digital > 24.5 kHz	
Stop band high (> - 100 dB)	analog > 1 MHz, digital > 27.5 kHz	
Dynamic Range (SFDR)	> 100 dB	
SINAD (300 Hz/1 kHz sine, 50 k SPS) 0dB from full scale	< -90 dB	< - 95 dB
IEPE Current Source per channel	Typ. 4.2 mA (+/- 7 % over temperature)	(n.a.)
Resistance AI- to M (ground)	Typ ~ 270Ohm (PTC)	
<b>Channel input impedance (AI+/AI-):</b>		
< 1kHz	> 1 MOhm	> 2 MOhm
5kHz	> 100 kOhm	> 40 kOhm
10kHz	> 60 kOhm	> 25 kOhm
20kHz	> 40 kOhm	> 8 kOhm
Error detection	Short circuit, open wire	
Max. cable length, shielded (depending on sensor)	100 m	
<b>Digital inputs/outputs</b>		
	24 V DC, dedicated inputs/outputs can be used for specific counting functions. All unused inputs/outputs can be used as normal input/output with standard specification.	
Channels and types	2 DI + 2 DC (configurable inputs/outputs); Type 1, LED indication	
Input options	Catch/Touch operation, counter value stored in separate variable on external event (rising or falling) Set to preset counter register with predefined value Set to reset counter register	
End value output	Output set when predefined value is reached	
Reference point initialization (RPI) input for relative encoder initialization	●	
<b>Input current p. channel @ V DC</b>		
24 V DC	Typically 5 mA	
5 V DC	> 1 mA	
15 V DC	> 5 mA	
30 V DC	< 8 mA	



## AC500

### Technical data

#### AC500 communication modules

- Up to 4 communications modules can be used on an AC500 CPU, up to 6 on AC500 V3 CPU.
- No external power supply required.

Type	CM592-DP	CM582-DP	CM597-ETH	CM598-CN	CM588-CN	CM579-PNIO
<b>AC500 V3 support</b>	(3)	(3)	–	(4)	–	•
<b>Communication interfaces</b>						
RJ45	–	–	• (x 2) (2)	–	–	• (x 2) (2)
RS-232 / 485	–	–	–	–	–	–
Terminal blocks (1)	–	–	–	•	•	–
Sub-D socket	•	•	–	–	–	–
<b>Protocols</b>	PROFIBUS DP V0/V1 master	PROFIBUS DP V0/V1 slave	Ethernet (TCP/IP, UDP/IP, Modbus TCP)	CANopen master	CANopen slave	PROFINET IO controller
Transfer Rate	9.6 kbit/s to 12 Mbit/s	9.6 kbit/s to 12 Mbit/s	10 / 100 Mbit/s	10 kbit/s to 1 Mbit/s	10 kbit/s to 1 Mbit/s	100 Mbit/s
<b>Co-processor</b>						
Memory	–	–	–	–	–	–
Additional features	Multi master functionality Max. Number of subscribers: • 126 (V0) • 32 (V1)	–	Online access, ICMP (Ping), DHCP, IP configuration protocol, UDP data exchange, Modbus TCP	CAN 2.0A CAN 2.0B CANopen	NMT Slave PDO server Heartbeat Nodeguard	RTC - Real-time Cyclic Protocol, Class 1 RTA - Real-time Acyclic Protocol DCP Discovery and Configuration Protocol CL-RPC - Connectionless Remote Procedure Call

Type	CM589-PNIO	CM589-PNIO-4	CM579-ETHCAT	CM574-RS	CM574-RCOM
<b>AC500 V3 support</b>	(3)	(3)	•	–	–
<b>Communication interfaces</b>					
RJ45	• (x 2) (2)	• (x 2) (2)	• (x 2)	–	–
RS-232 / 485	–	–	–	• (x 2)	• (x 2)
Terminal blocks (1)	–	–	–	• (x 2)	• (x 2)
Sub-D socket	–	–	–	–	–
<b>Protocols</b>	PROFINET IO device	PROFINET IO 4 x devices	EtherCAT master	Serial COM ASCII, Modbus RTU, CS31	Serial RCOM/RCOM+
Transfer Rate	100 Mbit/s	100 Mbit/s	10 / 100 Mbit/s	9.6 kBit/s up to 187.5 kBit/s	2,4 kBit/s to 19.2 kBit/s
<b>Co-processor</b>					
Memory	–	–	–	Programmable CPU like PM57x with PowerPC 50 MHz processor 256 kB program memory 384 kB data memory	–
Additional features	RTC - Real-time Cyclic Protocol, Class 1 RTA - Real-time Acyclic Protocol DCP Discovery and Configuration Protocol LLDP - Link Layer Discovery Protocol	RTC - Real-time Cyclic Protocol, Class 1 RTA - Real-time Acyclic Protocol DCP Discovery and Configuration Protocol LLDP - Link Layer Discovery Protocol	CoE (Can over Ethercat) process data (PDO) (cyclic) CoE Mailbox data (SDO) (acyclic) Distributed Clock (32-bit, 64-bit)	• Stand alone CPU in coupler module housing allowing to be used as standard serial interface or as free programmable serial interface coupler. • Independent internal CPU programmable for own communication protocol or data processing. • 2 x CS31 master, Modbus master/slave, free configurable, protocols ASCII.	–

(1) Plug-in terminal block included.

(2) 10 / 100 Mbit/s, full/half duplex with auto-sensing, 2-port switch integrated

(3) In preparation

(4) Only with CAN 2A/2B today

# AC500

## Technical data

### Communication interface modules

For all modules: max cable length for connected process signals is 1000 m for shielded cable and 600 m for unshielded ones. For all Input modules, the signal resolution for channel configuration is:  
 -10...+10 V: 12 bits + sign; 0...10 V, 0...20 mA, 4...20 mA: 12 bits. Temperature: 0.1 °C.

Type	DC551-CS31	CI5 90-CS31-HA (1)	CI592-CS31
<b>Communication Interface</b>			
Protocol	Proprietary CS31 bus protocol on RS485 interface		
ID configuration	Per rotary switches on front face from 00d to 99d		
Field bus connection on terminal units	CS31 field bus, via terminal / redundant for CI590-CS31-HA on TU551-CS31 or TU552-CS31		
<b>Number of Channels per Module</b>			
Digital	inputs	8	8
	outputs	–	–
Analog	inputs	–	4
	outputs	–	2
Digital configurable channels DC (configurable as inputs or outputs)	16	16	8
<b>Additional configuration of channels as</b>			
Fast counter	Configuration of max. 2 channels per module		
Occupies max. 1 DO or DC when used as counter	●	●	●
<b>Connection</b>			
Via terminal unit TU5xx	●	●	●
<b>Local I/O extension</b>			
Max. number of extension modules	max. 7 x S500 extension modules (standard or eCo), up to 31 stations with up to 120 DIs/120 DOs or up to 32 AIs/32AOs per station		
		not for S500-eCo I/O modules	
<b>Digital inputs</b>			
Input	signal voltage	24 V DC	
	characteristic acc. to EN 61132-2	Type 1	
0 signal		-3...+5 V DC	
Undefined signal state		5...15 V DC	
1 signal		15...30 V DC	
Residual ripple, range for	0 signal	-3...+5 V DC	
	1 signal	15...30 V DC	
Input time delay (0 -> 1 or 1 -> 0)	8 ms typically, configurable from 0.1 up to 32 ms		
<b>Digital outputs</b>			
Transistor outputs 24 V DC, 0.5 A	●		
Readback of output	●		
Outputs, supplied via process voltage UP	●		
Switching of 24 V load	●		
Output voltage at signal state 1	Process voltage UP - 0.8 V		
<b>Output current</b>			
Nominal current per channel	0.5 A		
Maximum (total current of all channels)	8 A	8 A	4 A
Residual current at signal state 0	< 0.5 mA		
Demagnetization when switching off inductive loads	By internal varistors		
<b>Analog inputs AI</b>			
Signal configuration per AI	Max. number per module and with regard to the configuration: AIs / Measuring points		
0...10 V / -10...+10 V	–		●
0...20 mA / 4...20 mA	–		4 / 4
RTD using 2/3 wire needs 1/2 channel(s)	–		4 / 2
0...10 V using differential inputs, needs 2 channels	–		4 / 2
-10...+10 V using differential inputs, needs 2 channels	–		4 / 2
Digital signals (digital input)	–		4 / 4

(1) Dedicated to High Availability.

## AC500

### Technical data

#### Communication interface modules

Type	DC551-CS31	CI590-CS31-HA (1)	CI592-CS31
<b>Data when using the AI as digital input</b>			
Input	time delay	-	8 ms typically, configurable from 0.1 up to 32 ms
	signal voltage	-	24 V DC
<b>Outputs, single configurable as</b>			
Possible configuration per AO		-	•
-10...+10 V		-	•
0...20 mA / 4...20 mA		-	•
Output	resistance (load) when used as current output	-	0...500 Ω
	loading capability when used as voltage output	-	±10 mA max.
<b>Potential isolation</b>			
Per module		•	•
Between fieldbus interface against the rest of the module		•	•
Voltage supply for the module		By external 24 V DC voltage via terminal UP	
<b>Process voltage UP</b>			
Nominal voltage		24 V DC	
Current consumption on UP			
Min. (module alone)		0.100 A	0.100 A
Max. (min. + loads)		0.100 A + load	0.100 A + load
Reverse polarity protection		•	
Fuse for process voltage UP		10 A miniature fuse	
<b>Approvals</b>		See detailed page 272 or <a href="http://www.abb.com/plc">www.abb.com/plc</a>	

(1) Dedicated to High Availability.



# AC500

## Technical data

### PROFIBUS-DP modules

Type	CI541-DP	CI542-DP
<b>Communication Interface</b>		
Protocol	PROFIBUS DP (DP-V0 and DP-V1 slave)	
ID configuration	Per rotary switches on front face from 00h to FFh	
Field bus connection on terminal units	Sub-D 9 poles on TU509, TU510 preferred but TU517/TU518 can be used with baud rate up to 1Mbaud	
<b>Number of Channels per Module</b>		
Digital	inputs	8
	outputs	8
Analog	inputs	–
	outputs	–
Digital configurable channels DC (configurable as inputs or outputs)	–	8
<b>Additional configuration of channels as</b>		
Fast counter (onboard I/O)	Configuration of max. 2 DI channels per module	
Occupies max 1 DO or DC when used as counter	●	
<b>Connection</b>		
Local I/O extension	●	
Max. number of extension modules	max. 10 x S500 extension modules (standard or eCo modules allowed). Fast counter from digital I/O modules can be also used.	
Via terminal unit TU5xx	●	
<b>Digital inputs</b>		
Input	signal voltage	24 V DC
	characteristic acc. to EN 61132-2	Type 1
0 signal		-3...+5 V DC
Undefined signal state		5...15 V DC
1 signal		15...30 V DC
Residual ripple, range for	0 signal	-3...+5 V DC
	1 signal	15...30 V DC
Input time delay (0 -> 1 or 1 -> 0)	8 ms typically, configurable from 0.1 up to 32 ms	
<b>Digital outputs</b>		
Transistor outputs 24 V DC, 0.5 A	●	
Readback of output	–	● (on DC outputs)
Outputs, supplied via process voltage UP	●	
Switching of 24 V load	●	
Output voltage at signal state 1	Process voltage UP - 0.8 V	
<b>Output current</b>		
Nominal current per channel	0.5 A	
Maximum (total current of all channels)	8 A	
Residual current at signal state 0	< 0.5 mA	
Demagnetization when switching off inductive loads	By internal varistors	
<b>Analog Inputs AI</b>		
	Max. number per module and with regard to the configuration: AIs / Measuring points	
Signal configuration per AI	4	–
0...10 V / -10...+10 V	4 / 4	–
0...20 mA / 4...20 mA	4 / 4	–
RTD using 2/3 wire needs 1/2 channel(s)	4 / 2	–
0...10 V using differential inputs, needs 2 channels	4 / 2	–
-10...+10 V using differential inputs, needs 2 channels	4 / 2	–
Digital signals (digital input)	4 / 4	–
<b>Data when using the AI as digital input</b>		
Input	Input time delay	8 ms typically, configurable from 0.1 up to 32 ms
	signal voltage	24 V DC

## AC500

### Technical data

#### PROFIBUS-DP modules

Type	CI541-DP	CI542-DP
<b>Outputs, single configurable as</b>		
Possible configuration per AO	●	-
-10...+10V	●	-
0...20 mA / 4...20 mA	●	-
Output resistance (load) when used as current output	0...500 Ω	-
loading capability when used as voltage output	±10 mA max.	-
<b>Potential isolation</b>		
Per module	●	●
Between fieldbus interface against the rest of the module	●	●
Between the channels		
input	-	-
output	-	-
Voltage supply for the module	By external 24 V DC voltage via terminal UP	
<b>Process voltage UP</b>		
Nominal voltage	24 V DC	
Current consumption on UP		
Min. (module alone)	0.260 A	
Max. (min. + loads)	0.260 A + load	
Reverse polarity protection	●	
Fuse for process voltage UP	10 A miniature fuse	
Approvals	See detailed page 272 or <a href="http://www.abb.com/plc">www.abb.com/plc</a>	

# AC500

## Technical data

### CANopen modules

Type	CI581-CN	CI582-CN	
<b>Communication interface</b>			
Protocol	CANopen slave, DS401 profile selectable using rotary switches		
ID configuration	Per rotary switches on front face for CANopen ID node from 00h to 7Fh and 80h to FFh for CANopen DS401 profile		
Field bus connection on terminal units	Terminal blocks on TU517/TU518 or TU509/TU510		
<b>Number of channels per module</b>			
Digital	inputs	8	
	outputs	8	
Analog	inputs	–	
	outputs	–	
Digital configurable channels DC (configurable as inputs or outputs)	–	8	
<b>Additional configuration of channels as</b>			
Fast counter (onboard I/O)	Configuration of max. 2 DI channels per module		
Occupies max. 1 DO or DC when used as counter	●	●	
<b>Connection</b>			
Local I/O extension	●		
Max. number of extension modules	max. 10 x S500 extension modules (standard or eCo modules are allowed)		
Via terminal unit TU5xx	●	●	
<b>Digital inputs</b>			
Input	signal voltage	24 V DC	
	characteristic acc. to EN 61132-2	Type 1	
0 signal		-3...+5 V DC	
Undefined signal state		5...15 V DC	
1 signal		15...30 V DC	
Residual ripple, range for	0 signal	-3...+5 V DC	
	1 signal	15...30 V DC	
Input time delay (0 -> 1 or 1 -> 0)	8 ms typically, configurable from 0.1 up to 32 ms		
<b>Digital outputs</b>			
Transistor outputs 24 V DC, 0.5 A	●		
Readback of output	–	● (on DC outputs)	
Outputs, supplied via process voltage UP	●		
Switching of 24 V load	●		
Output voltage at signal state 1	Process voltage UP - 0.8 V		
<b>Output current</b>			
Nominal current per channel	0.5 A		
Maximum (total current of all channels)	8 A		
Residual current at signal state 0	< 0.5 mA		
Demagnetization when switching off inductive loads	By internal varistors		
<b>Analog Inputs AI</b>	Max. number per module and with regard to the configuration: AIs / Measuring points		
Signal configuration per AI	4	–	
0...10 V / -10...+10 V	4 / 4	–	
0...20 mA / 4...20 mA	4 / 4	–	
RTD using 2/3 wire needs 1/2 channel(s)	4 / 2	–	
0...10 V using differential inputs, needs 2 channels	4 / 2	–	
-10...+10 V using differential inputs, needs 2 channels	4 / 2	–	
Digital signals (digital input)	4 / 4	–	
<b>Data when using the AI as digital input</b>			
Input	time delay	8 ms typically, configurable from 0.1 up to 32 ms	–
	signal voltage	24 V DC	–

## AC500

### Technical data

#### CANopen modules

Type	CI581-CN	CI582-CN
<b>Outputs, single configurable as</b>		
Possible configuration per AO	●	-
-10...+10 V	●	-
0...20 mA / 4...20 mA	●	-
Output	resistance (load) when used as current output	0...500 Ω
	loading capability when used as voltage output	±10 mA max.
<b>Potential isolation</b>		
Per module	●	●
Between fieldbus interface against the rest of the module	●	●
Between the channels	input	-
	output	-
Voltage supply for the module	By external 24 V DC voltage via terminal UP	
<b>Process voltage UP</b>		
Nominal voltage	24 V DC	
Current consumption on UP		
	Min. (module alone)	0.260 A
	Max. (min. + loads)	0.260 A + load
Reverse polarity protection	●	
Fuse for process voltage UP	10 A miniature fuse	
Approvals	See detailed page 272 or <a href="http://www.abb.com/plc">www.abb.com/plc</a>	

# AC500

## Technical data

### PROFINET IO RT device modules

Type	CI501-PNIO	CI502-PNIO	CI504-PNIO	CI506-PNIO
<b>Communication interface</b>				
Ethernet Interface				
Main protocol	PROFINET IO RT device			
ID Device configuration	By rotary switch on the front side, from 00h to FFh			
Ethernet connection on terminal units	2 x RJ45 with switch functionality for simple daisy chain on TU507-ETH or TU508-ETH or TU520-ETH			
Gateway Interface				
Gateway to	-	-	3 x RS232 / RS422 / RS485 ASCII serial interfaces	CAN / CANopen Master + 2 x RS232 / RS422 / RS485 ASCII serial interfaces
Fieldbus Protocol used	-	-	-	CAN 2A/2B Master - CANopen Master (1)
CAN physical interface	-	-	-	1 x 10 poles pluggable spring connector
Baudrate	-	-	-	Baudrate up to 1 MBit/s, Support for up to 126 CANopen Slaves
Serial interface				
Protocol used	-	-	3 x RS232 / RS422 or RS485	2 x RS232 / RS422 or RS485
Baudrate	-	-	Configurable from 300 bit/s to 115200 bit/s	
Fieldbus or serial connection on terminal units	-	-	3 x pluggable terminal blocks with spring on TU520-ETH	
<b>Number of channels per module</b>				
Digital	inputs	8	8	-
	outputs	8	8	-
Analog	inputs	4	-	-
	outputs	2	-	-
Digital configurable channels DC (configurable as inputs or outputs)		-	8	-
<b>Additional configuration of channels as</b>				
Fast counter (onboard I/O)		Configuration of max. 2 DI channels per module		
Occupies max. 1 DO or DC when used as counter		●	-	-
<b>Connection</b>				
Local I/O extension		●	●	●
Max. number of extension modules		max. 10 x S500 extension modules (standard or eCo modules allowed). Fast counter from digital I/O modules can be also used.		
Via terminal unit TU5xx		●	●	●
<b>Digital inputs</b>				
Input	signal voltage	24 V DC		
	characteristic acc. to EN 61132-2	Type 1		
0 signal		-3...+5 V DC		
Undefined signal state		5...15 V DC		
1 signal		15...30 V DC		
Residual ripple, range for	0 signal	-3...+5 V DC		
	1 signal	15...30 V DC		
Input time delay (0 -> 1 or 1 -> 0)		8 ms typically, configurable from 0.1 up to 32 ms		
<b>Digital outputs</b>				
Transistor outputs 24 V DC, 0.5 A		●	-	-
Readback of output		-	● (on DC outputs)	-
Outputs, supplied via process voltage UP		●	-	-
Switching of 24 V load		●	-	-
Output voltage at signal state 1		Process voltage UP - 0.8 V		

(1) Not simultaneously.

## AC500

### Technical data

#### PROFINET IO RT device modules

Type	CI501-PNIO	CI502-PNIO	CI504-PNIO	CI506-PNIO
<b>Output current</b>				
Nominal current per channel	500 mA at UP = 24 V DC		-	-
Maximum (total current of all channels)	8 A		-	-
Residual current at signal state 0	< 0.5 mA		-	-
Demagnetization when switching off inductive loads	By internal varistors		-	-
<b>Analog inputs AI</b>				
	Max. number per module and with regard to the configuration: AIs / Measuring points			
Signal configuration per AI	4	-	-	-
0...10 V / -10... +10 V	4 / 4	-	-	-
0...20 mA / 4...20 mA	4 / 4	-	-	-
RTD using 2/3 wire needs 1/2 channel(s)	4 / 2	-	-	-
0...10 V using differential inputs, needs 2 channels	4 / 2	-	-	-
-10...+10 V using differential inputs, needs 2 channels	4 / 2	-	-	-
Digital signals (digital input)	4 / 4	-	-	-
<b>Data when using the AI as digital input</b>				
Input	time delay	8 ms typically, configurable from 0.1 up to 32 ms	-	-
	signal voltage	24 V DC	-	-
<b>Outputs, single configurable as</b>				
Possible configuration per AO	●	-	-	-
-10...+10 V	●	-	-	-
0...20 mA / 4...20 mA	●	-	-	-
Output	resistance (load) when used as current output	0...500 Ω	-	-
	loading capability when used as voltage output	±10 mA max.	-	-
<b>Potential isolation</b>				
Per module	●	●	●	●
Between Ethernet interface against the rest of the module	●	●	●	●
Voltage supply for the module	By external 24 V DC voltage via terminal UP			
<b>Process voltage UP</b>				
Nominal voltage	24 V DC			
Current consumption on UP				
	min. (module alone)	0.260 A	0.150 A	
	max. (min. + loads)	0.260 A + load	0.150 A	
Reverse polarity protection	●			
Fuse for process voltage UP	10 A miniature fuse			
<b>Approvals</b>	See detailed page 272 or <a href="http://www.abb.com/plc">www.abb.com/plc</a>			

(1) Not simultaneously.

# AC500

## Technical data

### EtherCAT modules

Type	CI511-ETHCAT	CI512-ETHCAT	
<b>Communication interface</b>			
Protocol	EtherCAT slave with CAM-Switch configurable function on the digital outputs		
ID Device configuration	Address is defined by position on Ethernet bus		
Field bus connection on TUs	2 x RJ45 with switch functionality for simple daisy chain on TU507-ETH or TU508-ETH		
<b>Number of channels per module</b>			
Digital	inputs	8	8
	outputs	8	8
Analog	inputs	4	–
	outputs	2	–
Digital configurable channels DC (configurable as inputs or outputs)	–	8	
<b>Additional configuration of channels as</b>			
Fast counter (onboard I/O)	–		
Occupies max. 1 DO or DC when used as counter	–		
<b>Connection</b>			
Local I/O extension	●		
Max. number of extension modules	max. 10 x S500 extension modules (standard or eCo modules allowed). Fast counter from digital I/O modules can be also used.		
Via terminal unit TU5xx	●		
<b>Digital inputs</b>			
Input signal voltage	24 V DC		
Input characteristic acc. to EN 61 132-2	Type 1		
0 signal	-3...+5 V DC		
Undefined signal state	5...15 V DC		
1 signal	15...30 V DC		
Residual ripple, range for	0 signal	-3...+5 V DC	
	1 signal	15...30 V DC	
Input time delay (0 -> 1 or 1 -> 0)	8 ms typically, configurable from 0.1 up to 32 ms		
<b>Digital outputs</b>			
Transistor outputs 24 V DC, 0.5 A	●		
Readback of output	–	● (on DC outputs)	
Outputs, supplied via process voltage UP	●		
Switching of 24 V load	●		
Output voltage at signal state 1	Process voltage UP - 0.8 V		
<b>Output current</b>			
Nominal current per channel	500 mA at UP = 24 V DC		
Maximum (total current of all channels)	8 A		
Residual current at signal state 0	< 0.5 mA		
Demagnetization when switching off inductive loads	By internal varistors		
<b>Analog inputs AI</b>			
Max. number per module and with regard to the configuration: AIs / Measuring points			
Signal configuration per AI	4	–	
0...10 V / -10 V... +10 V	4 / 4	–	
0...20 mA / 4...20 mA	4 / 4	–	
RTD using 2/3 wire needs 1/2 channel(s)	4 / 2	–	
0...10 V using differential inputs, needs 2 channels	4 / 2	–	
-10...+10 V using differential inputs, needs 2 channels	4 / 2	–	
Digital signals (digital input)	4 / 4	–	
<b>Data when using the AI as digital input</b>			
Input	time delay	8 ms typically, configurable from 0.1 up to 32 ms	–
	signal voltage	24 V DC	–



## AC500

### Technical data

#### EtherCAT modules

Type	CI511-ETHCAT	CI512-ETHCAT
<b>Outputs, single configurable as:</b>		
Possible configuration per AO	•	-
-10...+10 V	•	-
0...20 mA / 4...20 mA	•	-
Output resistance (load) when used as current output	0...500 Ω	-
Output loading capability when used as voltage output	±10 mA max.	-
<b>Potential isolation</b>		
Per module	•	•
Between Ethernet interface against the rest of the module	•	•
Between the channels		
input	-	-
output	-	-
Voltage supply for the module	By external 24 V DC voltage via terminal UP	
<b>Process voltage UP</b>		
Nominal voltage	24 V DC	
Current consumption on UP		
min. (module alone)	0.260 A	
max. (min. + loads)	0.260 A + load	
Reverse polarity protection	•	
Fuse for process voltage UP	10 A miniature fuse	
<b>Approvals</b>	See detailed page 272 or <a href="http://www.abb.com/plc">www.abb.com/plc</a>	

# AC500

## Technical data

### Modbus TCP modules

Type	CI521-MODTCP	CI522-MODTCP	
<b>Communication interface</b>			
Ethernet Interface			
Main protocol	Modbus TCP		
ID Device configuration	By rotary switch on the front side, from 00h to FFh		
Ethernet connection on terminal units	2 x RJ45 with switch functionality for simple daisy chain on TU507-ETH or TU508-ETH		
<b>Number of channels per module</b>			
Digital	inputs	8	8
	outputs	8	8
Analog	inputs	4	–
	outputs	2	–
Digital configurable channels DC (configurable as inputs or outputs)		–	8
<b>Additional configuration of channels as</b>			
Fast counter (onboard I/O)	Configuration of max. 2 DI channels per module		
Occupies max. 1 DO or DC when used as counter	●		
<b>Connection</b>			
Local I/O extension	●		
Max. number of extension modules	max. 10 x S500 extension modules (standard or eCo modules allowed). Fast counter from digital I/O modules can be also used.		
Via terminal unit TU5xx	●	●	
<b>Digital inputs</b>			
Input	signal voltage	24 V DC	
	characteristic acc. to EN 61132-2	Type 1	
0 signal		-3...+5 V DC	
Undefined signal state		5...15 V DC	
1 signal		15...30 V DC	
Residual ripple, range for	0 signal	-3...+5 V DC	
	1 signal	15...30 V DC	
Input time delay (0 -> 1 or 1 -> 0)		8 ms typically, configurable from 0.1 up to 32 ms	
<b>Digital outputs</b>			
Transistor outputs 24 V DC, 0.5 A		●	
Readback of output		–	● (on DC outputs)
Outputs, supplied via process voltage UP		●	
Switching of 24 V load		●	
Output voltage at signal state 1		Process voltage UP - 0.8 V	
<b>Output current</b>			
Nominal current per channel		500 mA at UP = 24 V DC	
Maximum (total current of all channels)		8 A	
Residual current at signal state 0		< 0.5 mA	
Demagnetization when switching off inductive loads		By internal varistors	
<b>Analog inputs AI</b>		Max. number per module and with regard to the configuration: AIs / Measuring points	
Signal configuration per AI		4	–
0...10 V / -10... +10 V		4 / 4	–
0...20 mA / 4...20 mA		4 / 4	–
RTD using 2/3 wire needs 1/2 channel(s)		4 / 2	–
0...10 V using differential inputs, needs 2 channels		4 / 2	–
-10...+10 V using differential inputs, needs 2 channels		4 / 2	–
Digital signals (digital input)		4 / 4	–

(1) Not simultaneously.

## AC500

### Technical data

#### Modbus TCP modules

Type		CI521-MODTCP	CI522-MODTCP
<b>Data when using the AI as digital input</b>			
Input	time delay	8 ms typically, configurable from 0.1 up to 32 ms	–
	signal voltage	24 V DC	–
<b>Outputs, single configurable as</b>			
Possible configuration per AO		•	–
-10...+10 V		•	–
0...20 mA / 4...20 mA		•	–
Output	resistance (load) when used as current output	0...500 Ω	–
	loading capability when used as voltage output	±10 mA max.	–
<b>Potential isolation</b>			
Per module		•	•
Between Ethernet interface against the rest of the module		•	•
Voltage supply for the module		By external 24 V DC voltage via terminal UP	
<b>Process voltage UP</b>			
Nominal voltage		24 V DC	
Current consumption on UP			
min. (module alone)		0.260 A	
max. (min. + loads)		0.260 A + load	
Reverse polarity protection		•	
Fuse for process voltage UP		10 A miniature fuse	
<b>Approvals</b>		See detailed page 272 or <a href="http://www.abb.com/plc">www.abb.com/plc</a>	

(1) Not simultaneously.

## AC500

### Technical data

#### CS31 functionality

	AC500 CPU with integrated CS31 interface	S500 I/O with communication interface DC551-CS31 CI590-CS31-HA CI592-CS31
Master	Yes, at COM1	–
Slave	No	Yes / Redundant for CI590-CS31-HA
Protocols supported	ABB CS31 protocol	
<b>Diagnosis</b>		
Error indication	On LCD display of the CPU / AC500-eCo error LED	Via module LEDs
Online diagnosis	Yes	
Error code	Errors are recorded in the diagnosis system of the CPU	
Associated function blocks	Yes	
<b>Physical layer</b>		
Connection	RS485 / 2 x RS485 for CI590-CS31-HA for redundancy	Screw-type or spring-type terminals
Baud rate	187.5 kbit/s	
Distance	AC500-eCo: up to 50 m and up to 500 m using the isolator TK506 / AC500: up to 500 m; up to 2000 m using a repeater	
Max. number of modules on fieldbus	31 modules max. Please note: The CS31 bus interface occupies one or two module addresses (if counters are configured onboard or if the module is a mixed digital analog module). Depending on the configuration, or if the module contains also mixed digital analog I/O, connected extension modules can occupy further module addresses.	
<b>Configuration</b>		
Station address configuration	Using configuration tool (included in Automation Builder software suite)	Using rotary switches (99 max.)

#### Digital and mixed signal I/O modules, “Fast Counter” operating modes. Not applicable for DC541 or eCo-I/O modules (1)

Operating mode, configured in the user program of the AC500	Occupied inputs DI or DC	Occupied outputs DO or DC	Maximum counting frequency kHz
0 No counter	0	0	–
1 One count-up counter with “end value reached” indication	1	1	50
2 One count-up counter with “enable” input and “end value reached” indication	2	1	50
3 Two up/down counters	2	0	50
4 Two up/down counters with 1 counting input inverted	2	0	50
5 One up/down counter with “dynamic set” input	2	0	50
6 One up/down counter with “dynamic set” input	2	0	50
7 One up/down counter with directional discriminator For synchro transmitters using two counting pulses with an offset of 90° (track A and B)	2	0	50
8 –	0	0	–
9 One up/down counter with directional discriminator and double evaluation For synchro transmitters using two counting pulses with an offset of 90° towards each other (track A and B)	2	0	30
10 One up/down counter with directional discriminator and fourfold evaluation For synchro transmitters using two counting pulses with an offset of 90° towards each other (track A and B)	2	0	15

(1) See technical documentation for details.

# AC500

## System data

### Environmental Conditions

#### Process and supply voltages

24 V DC	Voltage	24 V (-15 %, +20 %)
	Protection against reverse polarity	yes

Allowed interruptions of power supply	DC supply	Interruption < 10 ms, time between 2 interruptions > 1 s, PS2
---------------------------------------	-----------	---

**Important:** Exceeding the maximum process and supply voltages could lead to unrecoverable damage of the system. The system could be destroyed. For the supply of the modules, power supply units according to PELV or SELV specifications must be used. The creepage distances and clearances meet the requirements of the overvoltage category II, pollution degree 2.

#### Assembly position

Horizontal	•
Vertical	•

#### Temperature

Operating	0 °C ... +60 °C	Preferred mounting position horizontal. Other mounting positions see manual.
Storage / Transport	-40 °C ... +70 °C	

#### Humidity

Operating / Storage	Max 95 % r. H. without condensation
---------------------	-------------------------------------

#### Air pressure

Operating	-1000 m ... 2000 m (1080 hPa ... 800 hPa)
Storage	<3500 m (>660 hPa)

#### Electromagnetic Compatibility

Radiated emission (radio disturbances)	Yes, Yes, in accordance with CISPR 16-2-3
Conducted emission (radio disturbances)	Yes, Yes, in accordance with CISPR 16-2-1, CISPR 16-1-2
Electrostatic discharge (ESD)	Yes, in accordance with IEC 61000-4-2, zone B, criterion B
	Electrostatic voltage in case of air discharge: 8 kV Electrostatic voltage in case of contact discharge: 6 kV
Fast transient interference voltages (burst)	Yes, in accordance with IEC 61000-4-4, zone B, criterion B
	Supply voltage units (DC): 2 kV
	Supply voltage units (AC): 2 kV
	Digital inputs/outputs (24 V DC): 1 kV
	Digital inputs/outputs (120...240 V AC): 2 kV
	Analog inputs/outputs: 1 kV Communication lines shielded: 1 kV I/O supply (DC-out): 2 kV
High energy transient interference voltages (surge)	Yes, in accordance with IEC 61000-4-5, zone B, criterion B
	Supply voltage units (DC): 1 kV CM* / 0.5 kV DM*
	Supply voltage units (AC): 2 kV CM* / 1 kV DM*
	Digital inputs/outputs (24 V DC): 1 kV CM* / 0.5 kV DM*
	Digital inputs/outputs (120...240 V AC): 2 kV CM* / 1 kV DM*
	Analog inputs/outputs: 1 kV CM* / 0.5 kV DM* Communication lines shielded: 1 kV CM* I/O supply (DC-out): 0,5 kV CM* / 0.5 kV DM*
Influence of radiated disturbances	Yes, in accordance with IEC 61000-4-3, zone B, criterion A
	Test field strength: 10 V/m
Influence of line-conducted interferences	Yes, in accordance with IEC 61000-4-6, zone B, criterion A
	Test voltage: 10 V
Influence of power frequency magnetic fields	Yes, in accordance with IEC 61000-4-8, zone B, criterion A
	30 A/m 50 Hz 30 A/m 60 Hz

#### WARNING!

##### Risk of malfunctions and damages to persons!

Unused slots for communication modules are not protected against contact discharge. Dust and Dirt may cause contact problems and malfunctions.

Unused slots for Communication Modules must be covered with Dummy Communication Modules ("TA524 - Dummy Communication Module").

I/O-Bus connectors must not be touched during operation.

In order to prevent malfunctions, it is recommended that the operating personnel discharge themselves prior to touching communication connectors or perform other suitable measures to reduce effects of electrostatic discharges.

# AC500

## System data

### Environmental Conditions

#### Environmental Tests

Storage	IEC 60068-2-1 Test Ab: cold withstand test -40 °C / 16 h IEC 60068-2-2 Test Bb: dry heat withstand test +70 °C / 16 h
Humidity	IEC 60068-2-30 Test Db: Cyclic (12 h / 12 h) Damp-Heat Test 55 °C, 93 % r. H. / 25 °C, 95 % r. H., 2 cycles
Vibration resistance	IEC 61131-2 / IEC 60068-2-6: 15 Hz ... 150 Hz, 1 g (with Memory Card inserted)
Shock resistance	IEC 60068-2-27: all 3 axes 15 g, 11 ms, half-sinusoidal

#### Mechanical Data

Wiring method	Spring terminals / Screw terminals	
Degree of protection	IP 20	
Assembly on DIN rail	DIN rail type	According to IEC 60715 35 mm, depth 7.5 mm or 15 mm
Assembly with screws	Screw diameter	4 mm
	Fastening torque	1.2 Nm

### Main dimensions mm, inches

Type	Nr communication modules	Length L	
		mm	inches
TB511-ETH	1	95.5	3.76
TB521-ETH / TB523-2ETH	2	123.5	4.86
TB541-ETH	4	179.5	7.07
TB5600-2ETH	0	67.5	2.66
TB5610-2ETH	1	95.5	3.76
TB5620-2ETH	2	123.5	4.86
TB5640-2ETH	4	179.5	7.07
TB5660-2ETH	6	235.5	10.5

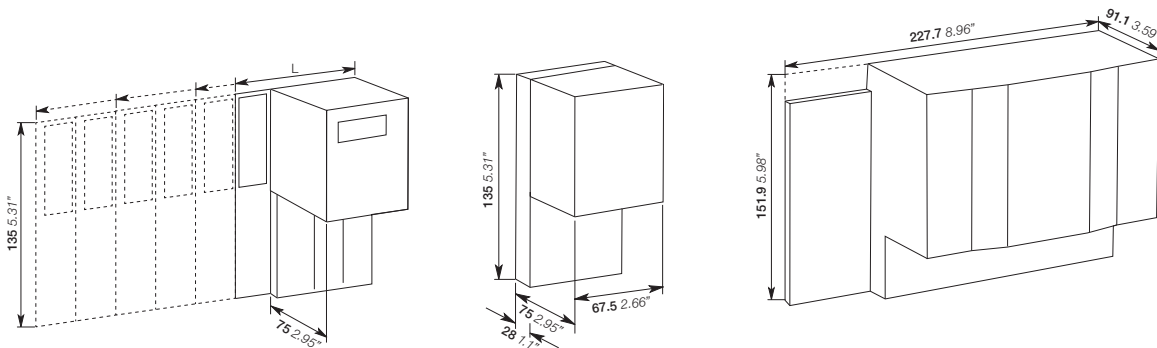





---

# AC500-XC

## PLC operating in eXtreme Conditions

<b>153</b>	<b>Key features</b>
<b>154–165</b>	<b>Ordering data</b>
<b>166–192</b>	<b>Technical data</b>
<b>193–194</b>	<b>System data</b>

79

ABB

PM592



SYS  
BATT  
I/O-Bus

ETH  
FBP  
COM1  
COM2

run

PWR



RUN



ERR



  
**WARNING**  
Use of  
incorrect  
battery may  
cause fire or  
explosion.

RUN

DIAG

VAL

CFG

ESC



OK



MC  
502

← INSERT  
→ PUSH

UP 24VDC 10W

CPU

05

# AC500-XC

## Key features



—

• Lower lifetime cost and many of the traditional practices are not required, such as: HVAC for the panel, shock absorbers, door sealing, etc...

—

• Resistance to:

- High humidity
- Salt mist
- Vibration
- High altitude
- Corrosive gases
- Temperature: from -40 to +70 °C

—

• All the benefits from AC500 range: ABB Ability™ Automation Builder engineering suite, I/O modules, scalable and flexible, same high performance communication, libraries and web services

## AC500-XC

### Ordering data

#### AC500 CPUs

- 2 internal serial interfaces, RS232 / RS485 configurable
- Display and 8 function keys for diagnosis and status
- Can be centrally extended with up to 10 I/O modules (S500) for a total of 320 Digital I/Os or 160 Analog I/Os
- Simultaneous operation of up to 4 external communication modules in any desired combination
- Optional memory card for data storage and program backup
- Can also be used as slave for PROFIBUS DP, CANopen or PROFINET IO using CM582-DP-XC, CM588-CN-XC, CM589-PNIO-XC or CM589-PNIO-4-XC communication modules
- Ethernet version provides web server and IEC 60870-5-104 remote control protocol
- Support of AC500-S safety PLC.

Program memory kB	Cycle time in $\mu$ s per instruction min. Bit/Word/Float. point	Integrated communication	Type	Order code	Price	Weight (1 pce) kg
512	0.06 / 0.09 / 0.7	Ethernet (1), 2 x serial	PM573-ETH-XC	1SAP330300R0271		0.150
512	0.05 / 0.06 / 0.5	2 x serial	PM582-XC	1SAP340200R0201		0.135
1024	0.05 / 0.06 / 0.5	Ethernet (1), 2 x serial	PM583-ETH-XC	1SAP340300R0271		0.150
4096	0.002 / 0.004 / 0.004	Ethernet (1), 2 x serial	PM591-ETH-XC	1SAP350100R0271		0.150
4096	0.002 / 0.004 / 0.004	Ethernet (1), 2 x serial	PM592-ETH-XC (2)	1SAP350200R0271		0.150



PM573-ETH-XC



PM592-ETH-XC

#### AC500 CPU PM595

- 2 Ethernet interfaces with integrated switch and software configurable protocol (PROFINET IO Controller, EtherCAT Master or Ethernet e.g. Modbus TCP client/server)
- 2 independent Ethernet interfaces for programming, online access, web server, Modbus TCP, IEC 60870-5-104 protocol e.g.
- 2 serial interfaces, RS232 / RS485 configurable
- Can be centrally extended with up to 10 I/O modules (S500 and/or S500-eCo modules allowed)
- Simultaneous operation of up to 2 external communication modules in any desired combination, no need of additional terminal base

Program memory MB	Cycle time in $\mu$ s per instruction min. Bit/Word/Float. point	Integrated communication	Type	Order code	Price	Weight (1 pce) kg
16	0.0006/0.001/0.001	2 x Ethernet for fieldbus (2 Ports switch), 2 x Ethernet (1), 2 x serial	PM595-4ETH-M-XC (2)	1SAP351500R0279		1.050

(1) Provides integrated web server and IEC 60870-5-104 remote control protocol on each interface independently.

(2) Provides integrated 4 GB flash disk for user data storage and data logging.



PM595-4ETH-M-XC

## AC500-XC

### Ordering data

#### Terminal base

- For mounting and connection of the CPUs and communication modules, not needed for PM595
- 1 to 4 plug-in communication modules
- Connection for communication coupler integrated in the CPU
- I/O interface for direct connection of up to 10 extension modules
- Connection COM1: 9-pole pluggable terminal block
- Connection COM2: D-Sub 9 (socket).

Number of coupler slots	Connection for coupler integrated in the CPU	Type	Order code	Price	Weight (1 pce) kg
1	Ethernet RJ45	TB511-ETH-XC	1SAP311100R0270		0.215
2	Ethernet RJ45	TB521-ETH-XC	1SAP312100R0270		0.215
4	Ethernet RJ45	TB541-ETH-XC	1SAP314100R0270		0.215



TB511-ETH-XC



TB541-ETH-XC

## AC500-XC

### Ordering data

#### AC500 Condition Monitoring CMS-XC

- PLC integrated condition monitoring and fast protection for high frequency signals (vibration, current, voltage, speed/encoder)
- FM502-CMS module needs function module terminal base TF5x1 for direct interfacing to CPU, communication couplers, other I/O
  - for stand-alone or control/safety integrated condition monitoring
- PM592 CPU to be used on same TF5x1 for data storage and signal processing or communication
  - C-code interface for own complex diagnosis algorithms, 4GB Flash disk for raw fingerprints and indicator trending
- FM502-CMS module:
  - 16 fast, precise analog inputs, all synchronously sampled; configurable as IEPE or +-10V
  - individual measurement configuration (start, stop, trigger) per channel
  - per channel up to 50ksamples/s and 24bit ADC resolution, adjustable sampling
  - encoder inputs (5V or 24V) up to 300kHz counter; 12 modes, incl. absolute SSI (1MHz)
  - fast data logging, compact WAV-Files delivered automatically to CPU, incl. synchronized encoder signal if configured
  - analogue values always available for fast protection in I/O image of CPU
- Included in ABB Ability™ Automation Builder: Configuration, libraries for CMS control and wav file handling, examples
- Available download package: Signal processing library, example programs with simple diagnosis, logging and automated triggering (2)

Number of coupler slots	Description	Type	Order code	Price	Weight (1 pce) kg
n.a.	Function Module for Condition Monitoring Systems, 16AI, 2DI, 2DC, 1x Encoder (A, B, Z)	FM502-CMS-XC	1SAP460400R0001		0.215
0	Function module terminal base for FM502, no coupler slots, 1x ETHERNET, 1x serial, spring terminals, 24 V DC	TF501-CMS-XC (1)	1SAP317000R0271		0.350
2	Function module terminal base for FM502, 2x coupler slots, 1x ETHERNET, 1x serial, spring terminals, 24 V DC	TF521-CMS-XC (1)	1SAP317200R0271		0.400

(1) Can only be used together with FM502 and PM592-ETH

(2) Download of Package under "Application Examples" at [www.abb.com/plc](http://www.abb.com/plc)



FM502-CMS-XC



TF501-CMS-XC



TF521-CMS-XC

## AC500-XC

### Ordering data

#### AC500-XC V3 CPUs

- 1x internal serial interface, RS232 / RS485 configurable (ACSII or Modbus RTU Master/Slave)
- 2x independent Ethernet interfaces which can also be used as switch and software configurable protocols like Modbus TCP, MQTT, Ethernet/IP Adapter or Scanner (2)(3), KNX (3) and BACnet B-C (3), IEC 60870-5-104 or IEC 61850 (3)
- Web server with Web Visu HTML5 for use with CP600 with Web interface
- 1x internal CAN interface, with CANopen Master/Slave (2), CAN 2A/2B and J1939 protocols
- Display and 8 function keys for diagnosis and status
- Can be centrally extended with up to 10 I/O modules, 320 I/Os (S500 and/or S500-eCo modules allowed)
- Simultaneous operation of several external communication modules in any desired combination
- To be used exclusively with new TB56xx-2ETH
- Optional memory card for data storage and program backup
- To be used only with ABB Ability™ Automation Builder 2.1 and later
- Support of AC500-S safety PLC.

Total user program memory MB (5)	Cycle time in µs per instruction min. Bit/Word/Float. point	Integrated communication	Type	Order code	Price	Weight (1 pce) kg
8 (thereof 1 for User Prog. code + Data)	0.020 / 0.020 / 0.120	2 x Ethernet with configurable protocol Ethernet/IP (2)(3), 1 x serial, 1x CAN interface	PM5630-2ETH-XC (1) (4)	1SAP331000R0278		0.135
80 (thereof 4 for User Prog. code + Data)	0.010 / 0.010 / 0.010	2 x Ethernet with configurable protocol Ethernet/IP (2)(3), 1 x serial, 1x CAN interface	PM5650-2ETH-XC (1) (4)	1SAP341000R0278		0.135
160 (thereof 16 for User Prog. code + Data)	0.002 / 0.002 / 0.002	2 x Ethernet with configurable protocol Ethernet/IP (2)(3), 1 x serial, 1x CAN interface	PM5670-2ETH-XC (1) (4)	1SAP351000R0278		0.135
160 (thereof 16 for User Prog. code + Data) / 8GB Flash disk	0.002 / 0.002 / 0.002	2 x Ethernet with configurable protocol Ethernet/IP (2)(3), 1 x serial, 1x CAN interface	PM5675-2ETH-XC (1) (4)	1SAP351500R0278		0.150

(1) Ethernet communication provides integrated web server, IEC 60870-5-104 remote control protocol and OPC UA server on each interface independently.

(2) In development, availability on demand

(3) Some communication protocols are licensed see following lines

(4) Only to be used with dedicated terminal base TB56xx-2ETH-XC

(5) Memory size of V2 versus V3 CPUs is not comparable. Projects have a different and separate User Program code and Data memory calculation in Automation Builder 2.4.0 version or later. System, configuration and web server parts are not counted anymore. This results in typically about 50 % lower memory usage compared to V2, and even lower memory usage compared to V3 projects compiled in Automation Builder 2.3.0 or before.



PM5650-2ETH-XC

#### Terminal base compatibility

	PM5630	PM5650	PM5670	PM5675
TB5600				
TB5610	●	●	●	●
TB5620	●			
TB5640		●		
TB5660			●	●

#### Feature licenses

Some HW or FW features need a license to be used on the new CPU. Which allows:

- more flexibility
- better adaptation to the needs

License Type	CPU runtime license to be used on internal Ethernet interface	Type	Order code
HW	Modbus TCP HA runtime license	PS5601-HA-MTCP	1SAP195400R0101
HW	IEC 61850 protocol runtime license	PS5602-61850	1SAP195600R0101
HW	Runtime license for KNX controller	PS5604-KNX	1SAP195800R0101
HW	BACnet protocol B-BC; runtime license	PS5607-BACnet-BC	1SAP195550R0101
HW	Motion control library runtime license	PS5611-MC	1SAP192150R0101
HW	Ethernet/IP scanner runtime license for AC500 V3 (1)	PS5613-EIP-S	1SAP196101R0101
HW	Ethernet/IP adapter runtime license for AC500 V3 (1)	PS5613-EIP-A	1SAP196100R0101

(1) In preparation



## AC500-XC

### Ordering data

#### AC500-XC V3 Terminal base

- For mounting and connection of the AC500-XC V3 CPUs only and communication modules
- 0, 1, 2, 4 or up to 6 plug-in communication modules
- Connection for communication coupler integrated in the CPU
- I/O interface for direct connection of up to 10 extension modules
- Connection COM1: 9-pole pluggable spring terminal block
- Connection CAN: 2x 5-pole pluggable spring terminal block
- 2x RJ45 Ethernet interfaces with configurable switch functionality

Number of coupler slots	Connection for coupler integrated in the CPU	Type	Order code	Price	Weight (1 pce) kg
0	2x RJ45 for Ethernet, 1x serial COM1 with pluggable spring connector and 1x2x5 poles pluggable spring connector for CAN/CANopen interface	TB5600-2ETH-XC	1SAP310300R0278		0.165
1		TB5610-2ETH-XC	1SAP311300R0278		0.190
2		TB5620-2ETH-XC	1SAP312300R0278		0.215
4		TB5640-2ETH-XC	1SAP314300R0278		0.265
6		TB5660-2ETH-XC	1SAP316300R0278		0.315



TB5600-2ETH-XC



TB5610-2ETH-XC



TB5620-2ETH-XC



TB5640-2ETH-XC



TB5660-2ETH-XC

#### Terminal base compatibility

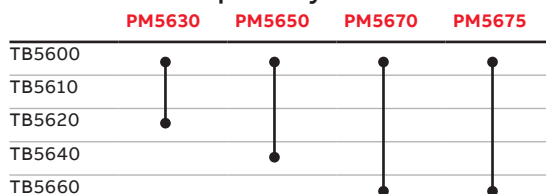

## AC500-XC

### Ordering data

#### Communication modules

Protocol	Connections	CPU V3 Support	Type	Order code	Price	Weight (1 pce) kg
PROFIBUS DP V0/V1 master	D-Sub 9	(2)	CM592-DP-XC	1SAP373200R0001		0.115
PROFIBUS DP V0/V1 slave	D-Sub 9	(2)	CM582-DP-XC	1SAP372200R0001		0.115
Ethernet (TCP/IP, UDP/IP, Modbus TCP)	2 x RJ45 - integrated switch	-	CM597-ETH-XC	1SAP373700R0001		0.115
CANopen master	Terminal block 2 x 5 poles spring	(1)	CM598-CN-XC	1SAP373800R0001		0.115
CANopen slave	Terminal block 2 x 5 poles spring	-	CM588-CN-XC	1SAP372800R0001		0.115
PROFINET IO RT controller	2 x RJ45 - integrated switch	Yes	CM579-PNIO-XC	1SAP370901R0101		0.115
PROFINET IO RT device	2 x RJ45 - integrated switch	(2)	CM589-PNIO-XC	1SAP372900R0011		0.115
PROFINET IO RT with 4 devices	2xRJ45 - integrated switch	(2)	CM589-PNIO-4-XC	1SAP372900R0111		0.115

(1) Only with CAN 2A/2B protocol

(2) In preparation



CM592-DP-XC



CM579-PNIO-XC

Protocol	Communication module	Communication interface module	I/O extension module		Applications	Support from CPU	
			S500-XC	S500-S-XC		V2	V3
Modbus TCP	Onboard Ethernet interface	CI521-MODTCP-XC / CI522-MODTCP-XC	●	-	HA, remote I/O	●	●
	CM597-ETH-XC				HA, remote I/O	●	-
PROFIBUS DP	CM592-DP-XC master	CI541-DP-XC / CI542-DP-XC	●	-	remote I/O	●	● (1)
			●	-	hot-swap I/O	●	-
PROFINET IO RT	CM579-PNIO-XC controller	CI501-PNIO-XC / CI502-PNIO-XC	●	●	remote I/O, safety I/O	●	●
			●	-	hot-swap I/O	●	●
		CI504-PNIO-XC / CI506-PNIO-XC	●	●	remote I/O, safety I/O	●	-
			●	-	hot-swap I/O	●	-
CANopen	Onboard CAN interface	CI581-CN-XC / CI582-CN-XC	-	-	remote I/O	-	● (2)
	CM598-CN-XC master		●	-	remote I/O	●	-
CS31 bus	Onboard COM1 interface	DC505-CS31-XC / CI592-CS31-XC	●	-	remote I/O	●	-
		CI590-CS31-HA-XC			HA	●	-

(1) In preparation

(2) Only support of the I/O from the CI58x communication interface module, not additional S500 modules today supported

## AC500-XC

### Ordering data

#### I/O modules

- Hot swap capable when mounted on hot swap terminal unit
- For central extension of the AC500-XC CPU
- For decentralized extension in combination with communication interface module (not for DC505-FBP)
- DC and AC: channels can be configured individually as inputs or outputs
- Terminal unit required (refer to table below).

#### Digital I/O

Number of	Input signal	Output type	Output signal	Terminal units	Type	Order code	Price	Weight (1 pce) kg
<b>DI/DO/DC</b>								
32 / - / -	24 V DC	-	-	TU516-XC	DI524-XC	1SAP440000R0001		0.200
- / - / 16	24 V DC	Transistor	24 V DC, 0.5 A	TU516-XC	DC522-XC	1SAP440600R0001		0.200
- / - / 24	24 V DC	Transistor	24 V DC, 0.5 A	TU516-XC	DC523-XC	1SAP440500R0001		0.200
16 / - / 16	24 V DC	Transistor	24 V DC, 0.5 A	TU516-XC	DC532-XC	1SAP440100R0001		0.200
- / 32 / -	-	Transistor	24 V DC, 0.5 A	TU516-XC	DO524-XC	1SAP440700R0001		0.200
8 / 8 / -	24 V DC	Relay	230 V AC, 3 A (1)	TU532-XC	DX522-XC	1SAP445200R0001		0.200
- / 8 / -	-	Transistor	24 V DC, 2 A	TU542-XC	DO526-XC	1SAP440800R0001		0.200

(1) Relay outputs, changeover contacts.



DI524-XC



DO524-XC

## AC500-XC

### Ordering data

#### Analog I/O

Number of	Input signal	Output signal	Terminal units	Type	Order code	Price	Weight (1 pce) kg
<b>AI/AO/AC</b>							
16 / 0 / 0	0...10 V, ±10 V 0/4...20 mA	–	TU516-XC	AI523-XC	1SAP450300R0001		0.200
4 / 4 / 0	PT100, PT1000, Ni1000	±10 V	TU516-XC	AX521-XC	1SAP450100R0001		0.200
0 / 0 / 8 (max. 4 current outputs)		0/4...20 mA	TU516-XC	AC522-XC	1SAP450500R0001		0.200
8 / 8 / 0 (max. 4 current outputs)			TU516-XC	AX522-XC	1SAP450000R0001		0.200
0 / 16 / 0 (max. 8 current outputs)			TU516-XC	AO523-XC	1SAP450200R0001		0.200
8 / 0 / 0	0...5 V, 0...10 V, ±50 mV, ±500 mV, 1 V, ±5 V, ±10 V, 0/4...20 mA, ±20 mA PT100, PT1000, Ni1000, Cu50, 0...50 kΩ, S, T, N, K, J	–	TU516-XC	AI531-XC	1SAP450600R0001		0.200

#### Analog/digital mixed I/O

Number of	Input signal	Output type	Output signal	Terminal unit	Type	Order code	Price	Weight (1 pce) kg
<b>AI/AO/DI/DO/DC</b>								
4 / 2 / 16 / - / 8	24 V DC, 0...10 V, ±10 V, 0/4...20 mA, PT100, PT1000, Ni100, Ni1000	Transistor	24 V DC, 0.5 A ±10 V, 0/4...20 mA	TU516-XC	DA501-XC	1SAP450700R0001		0.200
4 / 2 / - / 16 / 8				TU516-XC	DA502-XC	1SAP450800R0001		0.200

#### Function module

- Not hot swap capable

Functionality	Number of	Input signal	Output type	Output signal	Terminal unit	Type	Order code	Price	Weight (1 pce) kg
<b>DI/DO/DC</b>									
Encoder and PWM module	2 / - / 8	24 V DC and 2 encoder inputs	2 PWM outputs	–	TU516-XC	CD522-XC	1SAP460300R0001		0.125

#### Fast I/O module for direct mounting on the terminal base of the AC500 CPU

Functionality	Number of	Input signal	Output type	Output signal	Terminal unit	Type	Order code	Price	Weight (1 pce) kg
<b>DI/DO/DC</b>									
Interrupt I/O and fast counter	- / - / 8	24 V DC	Transistor	24 V DC, 0.5 A	N/A (2)	DC541-CM-XC (1)	1SAP470000R0001		0.100

(1) Function module, refer to table on page 178 for details. Terminal block for I/O signal connection included.

(2) Occupies a communication module slot.



AI523-XC



AI531-XC



DA501-XC



CD522-XC



DC541-CM-XC

## AC500-XC

### Ordering data

#### Communication interface modules

Number of	Input signal	Output type	Output signal	Terminal units	Type	Order code	Price	Weight (1 pce) kg
<b>AI/AO/DI/DO/DC</b>								
<b>For CS31-Bus</b>								
- / - / 8 / - / 16	24 V DC	Transistor	24 V DC, 0.5 A	TU552-CS31-XC	DC551-CS31-XC	1SAP420500R0001		0.200
- / - / - / - / 16	24 V DC	Transistor	24 V DC, 0.5 A	TU552-CS31-XC	CI590-CS31-HA-XC	1SAP421100R0001		0.200
4 / 2 / 8 / - / 8	24 V DC / 0...10 V, -10...+10 V, 0...20 mA, 4...20 mA, PT100, PT1000, Ni100, Ni1000	Transistor	24 V DC, 0.5 A / -10...+10 V, 0...20 mA, 4...20 mA	TU552-CS31-XC	CI592-CS31-XC	1SAP421200R0001		0.200
<b>For PROFIBUS-DP</b>								
4 / 2 / 8 / 8 / -	24 V DC / 0...10 V, -10...+10 V, 0...20 mA, 4...20 mA, PT100, PT1000, Ni100, Ni1000	Transistor	24 V DC, 0.5 A / -10...+10 V, 0...20 mA, 4...20 mA	TU510-XC / TU518-XC	CI541-DP-XC	1SAP424100R0001		0.200
- / - / 8 / 8 / 8	24 V DC	Transistor	24 V DC, 0.5 A	TU510-XC / TU518-XC	CI542-DP-XC	1SAP424200R0001		0.200
<b>For CANopen</b>								
4 / 2 / 8 / 8 / -	24 V DC / 0...10 V, -10...+10 V, 0...20 mA, 4...20 mA, PT100, PT1000, Ni100, Ni1000	Transistor	24 V DC, 0.5 A / -10...+10 V, 0...20 mA, 4...20 mA	TU510-XC / TU518-XC	CI581-CN-XC	1SAP428100R0001		0.200
- / - / 8 / 8 / 8	24 V DC	Transistor	24 V DC, 0.5 A	TU510-XC / TU518-XC	CI582-CN-XC	1SAP428200R0001		0.200
<b>For Ethernet-based protocol - PROFINET IO RT</b>								
4 / 2 / 8 / 8 / -	24 V DC / 0...10 V, -10...+10 V, 0...20 mA, 4...20 mA, PT100, PT1000, Ni100, Ni1000	Transistor	24 V DC, 0.5 A / -10...+10 V, 0...20 mA, 4...20 mA	TU508-ETH-XC	CI501-PNIO-XC	1SAP420600R0001		0.200
- / - / 8 / 8 / 8	24 V DC	Transistor	24 V DC, 0.5 A	TU508-ETH-XC	CI502-PNIO-XC	1SAP420700R0001		0.200
<b>For Ethernet-based protocol - Modbus TCP</b>								
4 / 2 / 8 / 8 / -	24 V DC / 0...10 V, -10...+10 V, 0...20 mA, 4...20 mA, PT100, PT1000, Ni100, Ni1000	Transistor	24 V DC, 0.5 A / -10...+10 V, 0...20 mA, 4...20 mA	TU508-ETH-XC	CI521-MODTCP-XC	1SAP422100R0001		0.200
- / - / 8 / 8 / 8	24 V DC	Transistor	24 V DC, 0.5 A	TU508-ETH-XC	CI522-MODTCP-XC	1SAP422200R0001		0.200

From	To	Output signal	Terminal units	Type	Order code	Price	Weight (1 pce) kg
<b>Gateway for Ethernet-based protocol - PROFINET IO RT</b>							
PROFINET IO	-	3 x RS232/485 ASCII serial interfaces	TU520-ETH-XC	CI504-PNIO-XC	1SAP421300R0001		0.200
PROFINET IO	1 x CAN 2A/2B or CANopen Master	2 x RS232/485 ASCII serial interfaces	TU520-ETH-XC	CI506-PNIO-XC	1SAP421500R0001		0.200



DC551-CS31-XC



CI541-DP-XC



CI581-CN-XC



CI502-PNIO-XC



CI506-PNIO-XC



CI521-MODTCP-XC

## AC500-XC

### Ordering data

#### Hot swap terminal units

For loadless hot swapping of digital and analog extension modules, when used in configurations with communication interface modules or AC500 CPU supporting hot swap. Hot swapping of attached extension module mounted on hot swap terminal unit is supported by AC500 V3 CPU modules as of PM5630-2ETH, AC500 V2 CPU modules as of PM585-ETH, CI501-PNIO, CI502-PNIO, CI541-DP, CI542-DP, CI521-MODTCP and CI522-MODTCP. AC500-S safety I/O modules cannot be used in configurations containing hot swap terminal units. Mixed configurations of hot swap terminal units with normal terminal units for digital and analog extension modules are possible. In the installation hot swap terminal units can be identified by the word Hot Swap and a white frame around the connection terminal area.

For	Supply	Connection type	Type	Order code	Price	Weight (1 pce) kg
I/O modules - for Hot Swap (2)	24 V DC	Spring	TU516-H-XC	1SAP415000R0001		0.300
I/O modules AC / Relay - for Hot Swap (2)	230 V AC	Spring	TU532-H-XC	1SAP415100R0001		0.300
I/O module DO526-XC - for Hot Swap (2)	24 V DC	Spring	TU542-H-XC	1SAP415200R0001		0.300

(2) I/O module as of index F0 needed for Hot Swap

#### Terminal units

For digital and analog extension modules and interface modules. Please note: for modules with relay outputs, terminal units for 230 V AC (TU532-XC) is required.

For	Supply	Connection type	Type	Order code	Price	Weight (1 pce) kg
Ethernet interface modules	24 V DC	Spring	TU508-ETH-XC	1SAP414000R0001		0.300
CANopen/PROFIBUS DP interface modules	24 V DC	Spring	TU510-XC	1SAP410800R0001		0.300
I/O modules	24 V DC	Spring	TU516-XC	1SAP412000R0001		0.300
CANopen/PROFIBUS DP interface modules	24 V DC	Spring	TU518-XC (1)	1SAP411200R0001		0.300
Ethernet gateway modules	24 V DC	Spring	TU520-ETH-XC	1SAP414400R0001		0.300
I/O modules AC / Relay	230 V AC	Spring	TU532-XC	1SAP417000R0001		0.300
I/O module DO526-XC	24 V DC	Spring	TU542-XC	1SAP413200R0001		0.300
CS31 interface modules	24 V DC	Spring	TU552-CS31-XC	1SAP410400R0001		0.300

(1) TU518-XC Terminal units can also be used with PROFIBUS DP CI modules with baud rate up to 1Mbaud.

(2) I/O module as of index F0 needed for Hot Swap



TU516-XC



TU520-ETH-XC



TU510-XC



TU508-ETH-XC



TU516-H-XC

## AC500-XC

### Ordering data

#### Terminal units compatibility

Type	For I/O modules			For communication interface modules				
	TU516-XC TU516-H-XC	TU532-XC TU532-H-XC	TU542-XC TU542-H-XC	TU508-ETH-XC	TU510-XC	TU518-XC	TU520-ETH-XC	TU552-CS31-XC
DA501-XC	•							
DA502-XC	•							
DC522-XC	•							
DC523-XC	•							
DC532-XC	•							
DI524-XC	•							
DO524-XC	•							
DO526-XC			•					
DX522-XC		•						
CD522-XC	• (2)							
AC522-XC	•							
AI523-XC	•							
AI531-XC	•							
AO523-XC	•							
AX521-XC	•							
AX522-XC	•							
DC551-CS31-XC								•
CI590-CS31-HA-XC								•
CI592-CS31-XC								•
CI501-PNIO-XC				•				
CI502-PNIO-XC				•				
CI504-PNIO-XC							•	
CI506-PNIO-XC							•	
CI521-MODTCP-XC				•				
CI522-MODTCP-XC				•				
CI541-DP-XC					•			• (1)
CI542-DP-XC					•			• (1)
CI581-CN-XC								•
CI582-CN-XC								•

(1) Can be used with baudrate up to 1Mbaud.

(2) CD522-XC cannot be used on TU516-H-XC.



## AC500-XC

### Ordering data

#### Accessories for AC500-XC

For	Description	Type	Order code	Price	Weight (1 pce) kg
AC500 CPUs	Memory card (2 GB) - not to be used for future project	MC502 (1)	1SAP180100R0001		0.020
	Memory card for high requirements (2 GB), for long term use e.g. data login	MC5141 (2)	1SAP180100R0041		0.020
	Lithium battery for data buffering	TA521	1SAP180300R0001		0.100
I/O modules	Pluggable marker holder for I/O modules, packing unit includes 10 pcs. Template available in the AC500 online help	TA523	1SAP180500R0001		0.300
AC500 CPU's, interface module, communication module and I/O modules	White labels, packing unit includes 10 pcs	TA525	1SAP180700R0001		0.100
Terminal base	Communication Module, blind cap	TA524	1SAP180600R0001		0.120
CPU terminal base	Accessories for wall mounting, packing unit includes 10 pcs	TA526	1SAP180800R0001		0.200
	5-pole power plug for AC500. Spare part. Can be plugged to CPU terminal base TB5x1. Packing unit includes 5 pcs	TA527	1SAP181100R0001		0.200
	9-pole COM1 plug for AC500. Spare part. Can be plugged to CPU terminal base TB5x1 or on TU520-ETH-XC. Packing unit includes 5 pcs	TA528	1SAP181200R0001		0.200
Communication modules	9-pole spring plug for CM574-RS/RCOM. Spare part. Packing unit includes 10 pcs	TA532	1SAP182000R0001		
	5-pole spring plug for CM575-DN/CM578-CN. Spare part. Packing unit includes 5 pcs	TA533	1SAP182100R0001		
	2x5-pole spring plug for CM588-CN and CM598-CN. Spare part. Packing unit includes 5 pcs.	TA534	1SAP182200R0001		
	10-pole spring plug for DC541-CM. Spare part. Packing unit includes 10 pcs.	TA536	1SAP183100R0001		
Protective caps for TB, TU and CM	10 x Sub-D plastic caps 20 x RJ45 plastic caps, 3 x RJ45 female 10 x M12 plastic caps	TA535	1SAP182300R0001		0.300
AC500 CPUs PM595	Protective cap, spare-parts, Packing unit includes 3 pcs	TA540	1SAP182600R0001		0.200
	Lithium battery for real-time-clock buffering	TA541	1SAP182700R0001		0.030
	Accessories for screw-mounting, Packing unit includes 20 pcs	TA543	1SAP182800R0001		0.100

(1) Product is transferred to life cycle phase classic in 2021.

(2) In preparation



MC502

# AC500-XC

## Technical data

### AC500-XC CPUs

Type	PM573-ETH-XC	PM582-XC	PM583-ETH-XC
Supply voltage	24 V DC		
Current consumption on 24 V DC			
Min. (module alone)	0.110 A	0.050 A	0.110 A
Max. (all couplers and I/Os)	0.810 A	0.750 A	0.810 A
Type of processor	Freescale ARM Processor 32-bit		
Processor clock frequency	50 MHz	84 MHz	84 MHz
Total RAM memory	32 MB	32 MB	32 MB
Total Flash memory	16 MB	16 MB	16 MB
Total user program memory (2)	2048 kB	928 kB	6144 kB
User program memory - Flash EPROM and RAM	512 kB	512 kB	1024 kB
Integrated user data memory	512 kB thereof 288 kB saved	416 kB thereof 288 kB saved	1024 kB thereof 288 kB saved
User flash disk (Data-storage, program access or also external with FTP)	-		
Plug-in memory card	Depending on memory card used: no SD-HC card allowed, use MC5141 for high requirements		
Web server's data for user RAM disk	1 024 kB	-	4 096 kB
Data buffering	battery		
Real-time clock (with battery back-up)	●		
<b>Cycle time for 1 instruction (minimum)</b>			
Binary	0.06 µs	0.05 µs	
Word	0.09 µs	0.06 µs	
Floating-point	0.7 µs	0.5 µs	
<b>Max. number of centralized inputs/outputs</b>			
Max. number of extension modules on I/O bus	up to max. 10 (S500 allowed)		
Digital inputs / outputs	320 / 320		
Analog inputs / outputs	160 / 160		
<b>Max. number of decentralized inputs/outputs</b>	depends on the used standard fieldbus (1)		
<b>Program execution</b>			
Cyclical / Time controlled / Multi tasking	● / ● / ●		
User program protection by password	●		
<b>Internal interfaces</b>			
<b>COM1</b>			
RS232 / RS485 configurable	●		
Connection (on terminal bases)	pluggable spring terminal block, use TK502 cable in accessory		
Programming, Modbus RTU, ASCII, CS31 master	●		
<b>COM2</b>			
RS232 / RS485 configurable	●		
Connection (on terminal bases)	D-Sub 9 female, use TK501 cable in accessory		
Programming, Modbus RTU, ASCII	●		
<b>FieldBusPlug</b>			
Serial neutral interface	●		
Connection (on terminal bases)	M12 male, 5 pole		
Functions	programming cable UTF-21-FBP, slave communication depending on FieldBusPlug used (PROFIBUS DP, CANopen, DeviceNet)		
<b>Ethernet</b>			
Ethernet connection (on terminal bases)	RJ45	-	RJ45
Ethernet functions: online Access, ICMP (Ping), DHCP, IP configuration protocol, UDP data exchange, Modbus TCP, HTTP (integrated Web server), IEC 60870-5-104 remote control protocol, MQTT, SNTP (Time synchronization), FTP server, SMTP client, Socket programming	●	-	●
<b>Ethernet-based fieldbus</b>			
Ethernet connection (on CPU module)	-		
Downloadable protocols like: PROFINET IO RT Controller, EtherCAT Master	-		
<b>CPU Display</b>	LC display and 8 function keys		
<b>Function</b>	RUN / STOP, status, diagnosis		
<b>RUN / STOP, RESET push buttons</b>	-		
<b>LEDs for various status display</b>	-		
<b>Timers / Counters</b>	unlimited / unlimited		
<b>Approvals</b>	See detailed page 272 or <a href="http://www.abb.com/plc">www.abb.com/plc</a>		

(1) e.g. CS31 fieldbus: up to 31 stations with up to 120 DIs / 120 DOs or up to 32 AIs / 32 AOs per station.

(2) Total user program memory: contains user program code, data and web server

# AC500-XC

## Technical data

### AC500-XC CPUs

Type	PM591-ETH-XC	PM592-ETH-XC	PM595-4ETH-M-XC
Supply voltage	24 V DC		
Current consumption on 24 V DC			
Min. (module alone)	0.150 A		0.400 A
Max. (all couplers and I/Os)	0.850 A		1.2 A
Type of processor	Freescale ARM Processor 32-bit		
Processor clock frequency	400 MHz	400 MHz	1 GHz
Total RAM memory	64 MB	64 MB	256 MB
Total Flash memory	32 MB	32 MB	64 MB
Total user program memory (2)	17920 kB		64 MB
User program memory - Flash EPROM and RAM	4096 kB		16384 kB
Integrated user data memory	5632 kB thereof 1536 kB saved		16384 kB thereof 3072 kB saved
User Flash disk (Data-storage, program access or also external with FTP)	–	Yes, 4 GB Flash non removable	
Plug-in memory card	Depending on memory card used: no SD-HC card allowed, use MC5141 for high requirements		
Web server's data for user RAM disk	8 MB		32 MB
Data buffering	battery		no battery needed
Real-time clock (with battery back-up)	●		
<b>Cycle time for 1 instruction (minimum)</b>			
Binary	0.002 μs		0.0006 μs
Word	0.004 μs		0.001 μs
Floating-point	0.004 μs		0.001 μs
<b>Max. number of centralized inputs/outputs</b>			
Max. number of extension modules on I/O bus	up to max. 10 (S500 allowed)		
Digital inputs / outputs	320 / 320		
Analog inputs / outputs	160 / 160		
<b>Max. number of decentralized inputs/outputs</b>	depends on the used standard fieldbus (1)		
<b>Program execution</b>			
Cyclical / Time controlled / Multi tasking	● / ● / ●		
User program protection by password	●		
<b>Internal interfaces</b>			
<b>COM1</b>			
RS232 / RS485 configurable	●		
Connection (on terminal bases)	pluggable spring terminal block, use TK502 cable in accessory		
Programming, Modbus RTU, ASCII, CS31 master	●		
<b>COM2</b>			
RS232 / RS485 configurable	●		
Connection (on terminal bases)	D-sub 9 female, use TK501 cable in accessory		
Programming, Modbus RTU, ASCII	●		
<b>FieldBusPlug</b>			
Serial neutral interface	●		
Connection (on terminal bases)	M12 male, 5 pole		
Functions	programming cable UTF-21-FBP, slave communication depending on FieldBusPlug used (PROFIBUS DP, CANopen, DeviceNet)		
<b>Ethernet</b>			
Ethernet connection (on terminal bases)	RJ45	RJ45	2x RJ45
Ethernet functions: online Access, ICMP (Ping), DHCP, IP configuration protocol, UDP data exchange, Modbus TCP, HTTP (integrated Web server), IEC 60870-5-104 remote control protocol, MQTT, SNTP (Time synchronization), FTP server, SMTP client, Socket programming	●	●	●
<b>Ethernet-based fieldbus</b>			
Ethernet connection (on CPU module)	–		4 x RJ45 (2x interfaces with 2-port switch)
Downloadable protocols like: PROFINET IO RT Controller / EtherCAT Master or Ethernet e.g. Modbus TCP client/server	–		●
<b>CPU display</b>	LC display and 8 function keys		
<b>Function</b>	RUN / STOP, status, diagnosis		
RUN / STOP, RESET push buttons	–		●
LEDs for various status display	–		●
<b>Timers / Counters</b>	unlimited / unlimited		
<b>Approvals</b>	See detailed page 272 or <a href="http://www.abb.com/plc">www.abb.com/plc</a>		

(1) e.g. CS31 fieldbus: up to 31 stations with up to 120 DIs / 120 DOs or up to 32 AIs / 32 AOs per station.

(2) Total user program memory: contains user program code, data and web server

# AC500-XC

## Technical data

### AC500-XC V3 CPUs

Type	PM5630-2ETH-XC	PM5650-2ETH-XC	PM5670-2ETH-XC	PM5675-2ETH-XC
Supply voltage	24 V DC			
Current consumption on 24 V DC				
Min. typ. (module alone)	0.110 A	0.120 A	0.140 A	
Max. typ. (all couplers and I/Os)	0.850 A	0.900 A	0.950 A	
Type of processor	TI ARM Cortex-A9 32-bit-RISC			
Processor clock frequency	300 MHz	600 MHz	1 GHz	1 GHz
Total RAM memory	128 MB	256 MB	512 MB	512 MB
Total Flash memory	128 MB	512 MB	1024 MB	1024 MB
Total user program memory	8 MB	80 MB	160 MB	160 MB
Thereof User program code and data (4) (dynamically allocated)	2 MB (5)	8 MB (5)	32 MB (5)	32 MB (5)
Thereof User web server Data max.	6 MB	72 MB	128 MB	128 MB
User data memory saved	256 kB	256 kB	1.5 MB	1.5 MB
Thereof VAR Retain persistent	128 kB	128 kB	1024 kB	1024 kB
Thereof %M memory (e.g. Modbus register memory)	128 kB	128 kB	512 kB	512 kB
User flash disk (Data-storage, programm access or also external with FTP)				8 GB Flash non removable
Plug-in memory card	use MC5141 for high requirements preferably			
Data buffering	battery			
Real-time clock (with battery back-up)	●			
<b>Cycle time for 1 instruction (minimum)</b>				
Binary	0.02 µs	0.01 µs	0.002 µs	0.002 µs
Word	0.02 µs	0.01 µs	0.002 µs	0.002 µs
Floating-point	0.12 µs	0.01 µs	0.002 µs	0.002 µs
<b>Program execution</b>				
Cyclical	●			
Minimum cycle time configurable for cyclical task	1 ms	1 ms	0.5 ms	
Time controlled	●			
Multi tasking	●			
User program protection by password	●			
Motion control with EtherCAT or CAN sync onboard and PLCopen library PS5611-MC(2)				
Min. EtherCAT master cycle time	2 ms	1 ms	0.5 ms	
Number of synchronized axis (6) in 1 ms	-	8	16	
Number of synchronized axis (6) in 2 ms	4	16	32	
Number of synchronized axis (6) in 4 ms	8	32	64	
<b>Communication modules and terminal bases supported</b>				
Max. number of communication modules on terminal base TB				
TB5600-2ETH-XC	0 slot	0 slot	0 slot	
TB5610-2ETH-XC	1 slot	1 slot	1 slot	
TB5620-2ETH-XC	2 slots	2 slots	2 slots	
TB5640-2ETH-XC	-	4 slots	4 slots	
TB5660-2ETH-XC	-	-	6 slots	
Type of safety module supported				
SM560-S-XC - safety module	●			
SM560-S-FD-1-XC - safety module with F-Device functionality for 1 PROFIsafe network	●(2)			
SM560-S-FD-4-XC - safety module with F-Device functionality for 1 PROFIsafe network	●(2)			
Type of communication module supported				
Max. number of variables allowed for each communication module supported				
Input variables	4 kB		5 kB	
Output variables	4 kB		5 kB	
CM582-DP-XC - PROFIBUS DP V0/V1 Slave	●(2)			
CM592-DP-XC - PROFIBUS DP V0/V1 Master	●(2)			
CM579-PNIO-XC - PROFINET IO RT controller	●			
CM589-PNIO-XC - PROFINET IO RT device	●(2)			
CM589-PNIO-4-XC - PROFINET IO RT with 4 devices	●(2)			
CM597-ETH-XC - Ethernet interface	-			
CM588-CN-XC - CAN, CANopen Slave	-			
CM598-CN-XC - CAN, CANopen Master	● only CAN 2A/2B today			
<b>Max. number of centralized inputs/outputs</b>				
Max. number of extension modules on I/O bus	up to max. 10 (S500 and/or S500-eCo I/O modules allowed)			
Digital	inputs/outputs 320/320			
Analog	inputs/outputs 160/160			
<b>Max. number of decentralized inputs/outputs</b>	depends on the used standard fieldbus (1)			

(1) e.g. CANopen fieldbus: up to 127 stations with I/O from CI module only per station. (2) In preparation, availability on demand (3) Feature is licensed, runtime license per CPU. (4) Total user program memory: contains user program code, data (dynamically allocated), web server memory and infrastructure (5) Memory size of V2 versus V3 CPUs is not comparable. Projects have a different and separate User Program code and Data memory calculation in Automation Builder 2.4.0 version or later: System, configuration and web server parts are not counted anymore. This results in typically about 50 % lower memory usage compared to V2, and even lower memory usage compared to V3 projects compiled in Automation Builder 2.3.0 or before. (6) + 1 e.g. for virtual axis

# AC500-XC

## Technical data

### AC500-XC V3 CPUs

Type	PM5630-2ETH-XC	PM5650-2ETH-XC	PM5670-2ETH-XC	PM5675-2ETH-XC
<b>Internal interfaces for communication</b>				
<b>COM1</b>				
RS232 / RS485 configurable	●			
Connection (on terminal bases or CPU module)	pluggable spring terminal block			
Modbus RTU Master/Slave, ASCII	●			
<b>CANopen</b>				
Serial interface	CAN serial interface			
Connection (on terminal bases)	Pluggable spring terminal block, 2x 5 poles			
Functions	CANopen® Master communication, CAN 2A/2B, J1939 protocol, CAN sync			
Max. number of variables allowed				
Input variables	2 kB	4 kB	5 kB	
Output variables	2 kB	4 kB	5 kB	
<b>Ethernet</b>				
Ethernet connection (on terminal bases)	2x independent Ethernet interfaces for several uses 2x RJ45 with 2x separated interfaces and MAC-Address, could be used as 2-port switch with 1x interface			
<b>Ethernet functions (5):</b>				
Ethernet Switch on ETH1 / ETH2	●			
Online Access, ICMP (Ping), DHCP, programming	●			
Nb of parallel connections	6	8	12	
IP configuration protocol	●			
UDP data exchange, Network variables	● / ●			
HTTP / HTTPs (integrated web server)	●			
Nb of parallel connections	4	8	12	
Web Visu for data visualisation on web server	●			
HTML5				
SNTP (Time synchronization)	●			
FTP / FTPs server	●			
Nb of parallel connections	2	4	4	
SMTP client	●			
Socket programming	●			
<b>Modbus TCP Client / Server</b>	● / ●			
Nr of Modbus clients ModMast in parallel on a CPU Master (Server)	30	50	120	
Nr of Modbus server in parallel (for SCADA access e.g.)	15	25	50	
<b>IEC 60870-5-104 remote control protocol - Support 2nd connection</b>	●			
Nr of free tags + additional license for extension (2)	1000	5000	10000	
Control Station - Nb connections	5	10	20	
Sub-Station - Nb connections	5	10	20	
<b>OPC UA Server (Micro Embedded Device Server) with security</b>	●			
Nr of free tags + additional license for extension (2)	3000	10000	30000	
Nr of Connections	10	20	50	
min sampling rate (limit)	500 ms	100 ms	50 ms	
<b>OPC DA Server AE</b>	●			
Nr of Connections	8	8	8	
<b>Ethernet-based fieldbus protocols on onboard Ethernet interface (5)</b>				
Downloadable protocols (licensed feature with runtime license per CPU):	available on one Ethernet interface, the other interface can be sometimes used as switch			
<b>Ethernet/IP Scanner communication</b>	● (2)(3)	● (2)(3)	● (2)(3)	
<b>Ethernet/IP Adapter communication</b>	● (2)(3)	● (2)(3)	● (2)(3)	
Maximum allowed number of input/output variables for the onboard fieldbus protocol	0.5 kB / 0.5 kB	0.5 kB / 0.5 kB	0.5 kB / 0.5 kB	
<b>IEC 61850 - MMS server Edition 1 / GOOSE communication</b>	● / ● (3)	● / ● (3)	● / ● (3)	
Maximum number of allowed variables in variables list	1000	5000	10000	
<b>KNX - Building communication</b>	● (3)	● (3)	● (3)	
Maximum number of allowed Objects variables on the interface	1000	1000	1000	
<b>BACnet-BC - Infrastructure communication</b>	● (3)	● (3)	● (3)	
Maximum number of allowed Objects variables on the interface	1000	1000	1000	
<b>CPU display</b>				
Function	LC display and 8 function keys			
LEDs for various status display	●			
Timer/Counter	unlimited/unlimited			
<b>Approvals</b>				
	See detailed page 272 or <a href="http://www.abb.com/plc">www.abb.com/plc</a>			

(1) e.g. CANopen fieldbus: up to 127 stations with I/O from CI module only per station. (2) In preparation, availability on demand (3) Feature is licensed, runtime license per CPU. (4) Recommendation (5) Using parallel protocols on the same and/or different port reduces the bandwidth and the CPU performance

# AC500-XC

## Technical data

### Digital S500-XC I/O modules

Type	DI524-XC	DC522-XC	DC523-XC	DC532-XC	DO524-XC	DO526-XC	DX522-XC	
<b>Number of channels per module</b>								
Digital	inputs	32	–	–	16	–	–	8
	outputs	–	–	–	–	32	8	8 relays
Configurable channels DC (configurable as inputs or outputs)		–	16	24	16	–	–	–
<b>Additional configuration of channels as</b>								
Fast counter		configuration of max. 2 channels per module, operating modes see table on page 192						
Occupies max. 1 DO or DC when used as counter		–	●	●	●	–	–	–
Connection via terminal unit		●	●	●	●	●	●	●
<b>Digital inputs</b>								
Input signal voltage		24 V DC				–	–	24 V DC
Input characteristic acc. to EN 61132-2		Type 1				–	–	Type 1
0 signal		-3...+5 V DC				–	–	-3...+5 V DC
Undefined signal state		5...15 V DC				–	–	5...15 V DC
1 signal		15...30 V DC				–	–	15...30 V DC
Input time delay (0 -> 1 or 1 -> 0)		8 ms typically, configurable from 0.1 up to 32 ms				–	–	8 ms typically, configurable from 0.1 up to 32 ms
<b>Input current per channel</b>								
At input voltage		24 V DC	5 mA typically		–	–	5 mA typically	
		5 V DC	> 1 mA		–	–	> 1 mA	
		15 V DC	> 5 mA		–	–	> 5 mA	
		30 V DC	< 8 mA		–	–	< 8 mA	
<b>Digital outputs</b>								
Transistor outputs 24 V DC		–	●	●	●	●	●	–
Readback of output		–	●	●	●	–	–	–
Relay outputs, supplied via process voltage UP, changeover contacts		–	–	–	–	–	–	●
Switching of load		24 V	●	●	●	●	●	●
		230 V	–	–	–	–	–	●
Output voltage at signal state 1		–	process voltage UP minus 0.8 V			–	process voltage UP minus 0.4 V	
<b>Output current</b>								
Nominal current per channel		–	500 mA at UP = 24 V			2 A at UP = 24 V	–	
Maximum (total current of all channels)		–	8 A			16 A	–	
Residual current at signal state 0		–	< 0.5 mA			–	–	
Demagnetization when switching off inductive loads		–	by internal varistors			–	–	
<b>Switching frequency</b>								
For inductive load		–	0.5 Hz max.			0.5 Hz max.	2 Hz	
For lamp load		–	11 Hz max. at max. 5 W			–	–	
Short-circuit / overload proofness		–	●	●	●	●	by external fuse / circuit breaker 6 A gL/gG per channel	
Overload indication (I > 0.7 A)		–	after approx. 100 ms			–	–	
Output current limiting		–	yes, with automatic reclosure			–	–	
Proofness against reverse feeding of 24 V signals		–	●	●	●	●	–	
<b>Contact rating</b>								
For resistive load, max.		–	–			–	3 A at 230 V AC 2 A at 24 V DC	
For inductive load, max.		–	–			–	1.5 A at 230 V AC 1.5 A at 24 V DC	
For lamp load		–	–			–	60 W at 230 V AC 10 W at 24 V DC	

## AC500-XC

### Technical data

#### Digital S500-XC I/O modules

Type	DI524-XC	DC522-XC	DC523-XC	DC532-XC	DO524-XC	DO526-XC	DX522-XC
<b>Lifetime (switching cycles)</b>							
Mechanical lifetime	–						300 000
Lifetime under load	–						300 000 at 24 V DC / 2 A 200 000 at 120 V AC / 2 A 100 000 at 230 V AC / 3 A
Spark suppression for inductive AC load	–						external measure depending on the switched load
Demagnetization for inductive DC load	–						external measure: free-wheeling diode connected in parallel to the load
<b>Process voltage UP</b>							
Nominal voltage	24 V DC						
Current consumption on UP							
Min. (module alone)	0.150 A	0.100 A	0.150 A	0.150 A	0.050 A	0.050 A	0.050 A
Max. (min. + loads)	0.150 A	0.100 A + load	0.150 A + load	0.150 A + load	0.100 A + load	0.050 A + load	0.050 A + load
Reverse polarity protection	●	●	●	●	●	●	●
Fuse for process voltage UP	10 A miniature fuse						
Connections for sensor voltage supply. Terminal 24 V and 0 V for each connection. Permitted load for each group of 4 or 8 connections: 0.5 A	–	8	4	–	–	–	–
Short-circuit and overload proof 24 V DC sensor supply voltage	–	●	●	–	–	–	–
<b>Maximum cable length for connected process signals</b>							
Cable	shielded	1000 m					
	unshielded	600 m					
<b>Potential isolation</b>							
Per module	●						
Between channels	input	–	–	–	–	–	–
	output	–	–	–	–	–	in groups of 4 ●
Voltage supply for the module	internally via extension bus interface (I/O bus)						
Fieldbus connection	via AC500-XC CPU or all communication interface modules (except DC505-FBP fieldbus Plug module)						
Address setting	automatically (internal)						



## AC500-XC

### Technical data

#### Analog S500-XC I/O modules

Type		AX521-XC	AX522-XC	AC522	AI523-XC	AO523-XC	AI531-XC	
<b>Number of channels per module</b>								
Individual configuration, analog	inputs	4	8	–	16	–	8	
	outputs	4	8	–	–	16	–	
	configurable	–	–	8	–	–	–	
<b>Signal resolution for channel configuration</b>								
-10...+10 V		12 bits + sign						15 bits + sign
0...10 V		12 bits						15 bits
0...20 mA, 4...20 mA		12 bits						15 bits
Temperature: 0.1 °C		•	•	•	•	–	•	
<b>Monitoring configuration per channel</b>								
Plausibility monitoring		•	•	•	•	•	•	
Wire break & short-circuit monitoring		•	•	•	•	•	•	
<b>Analog Inputs AI</b>								
Signal configuration per AI		max. number per module and with regard to the configuration: AIs / Measuring points (depending on the use of 2/3-wire connection or differential input)						
0...10 V		4 / 4	8 / 8	8 / 8	16 / 16	–	8 / 8	
-10...+10 V		4 / 4	8 / 8	8 / 8	16 / 16	–	8 / 8	
0...20 mA		4 / 4	8 / 8	8 / 8	16 / 16	–	8 / 8	
4...20 mA		4 / 4	8 / 8	8 / 8	16 / 16	–	8 / 8	
<b>Pt100</b>								
-50...+400 °C (2-wire)		4 / 4	8 / 8	8 / 8	16 / 16	–	8 / 8	
-50...+400 °C (3-wire), 2 channels		4 / 2	8 / 4	8 / 4	16 / 8	–	8 / 8	
-50...+400 °C (4-wire)		–	–	–	–	–	8 / 8	
-50...+70 °C (2-wire)		4 / 4	8 / 8	8 / 8	16 / 16	–	8 / 8	
-50...+70 °C (3-wire), 2 channels		4 / 2	8 / 4	8 / 4	16 / 8	–	8 / 8	
-50...+70 °C (4-wire)		–	–	–	–	–	8 / 8	
<b>Pt1000</b>								
-50...+400 °C (2-wire)		4 / 4	8 / 8	8 / 8	16 / 16	–	8 / 8	
-50...+400 °C (3-wire), 2 channels		4 / 2	8 / 4	8 / 4	16 / 8	–	8 / 8	
-50...+400 °C (4-wire)		–	–	–	–	–	8 / 8	
<b>Ni1000</b>								
-50...+150 °C (2-wire)		4 / 4	8 / 8	8 / 8	16 / 16	–	8 / 8	
-50...+150 °C (3-wire), 2 channels		4 / 2	8 / 4	8 / 4	16 / 8	–	8 / 8	
-50...+150 °C (4-wire)		–	–	–	–	–	8 / 8	
Cu50 -200...+200 °C		–	–	–	–	–	8 / 8	
Resistor 0...50 kΩ		–	–	–	–	–	8 / 8	
Thermocouples of types J, K, T, N, S		–	–	–	–	–	8 / 8	
0...10 V using differential inputs, 2 channels		4 / 2	8 / 4	8 / 4	16 / 8	–	8 / 8	
-10...+10 V using differential inputs, 2 channels		4 / 2	8 / 4	8 / 4	16 / 8	–	8 / 8	
Digital signals (digital input)		4 / 4	8 / 8	8 / 8	16 / 16	–	8 / 8	
Input resistance per channel		voltage: > 100 kΩ current: approx. 330 Ω				–	voltage: > 100 kΩ current: approx. 330 Ω	
Time constant of the input filter		voltage: 100 μs current: 100 μs				–	voltage: 100 μs current: 100 μs	
Conversion cycle		2 ms (for 8 AI + 8 AO), 1 s for Pt100/1000, Ni1000				–	1 ms (for 8 AI + 8 AO), 1 s for Pt100/1000, Ni1000	
Overvoltage protection		•	•	•	•	–	•	

## AC500-XC

### Technical data

#### Analog S500-XC I/O modules

Type		AX521-XC	AX522-XC	AC522	AI523-XC	AO523-XC	AI531-XC	
<b>Data when using the AI as digital input</b>								
Input	time delay	8 ms typically, configurable from 0.1 up to 32 ms				–	8 ms typically, configurable from 0.1 up to 32 ms	
	signal voltage	24 V DC				–	24 V DC	
Signal	0	-30...+5 V				–	-30...+5 V	
	1	13...30 V				–	13...30 V	
<b>Analog outputs AO</b>								
Possible configuration per AO		Max. number of AOs per module and with regard to the configuration:						
	-10...+10 V	4	8	8	–	16	–	
	0...20 mA	4	4	4	–	8	–	
	4...20 mA	4	4	4	–	8	–	
Output	resistance (burden) when used as current output	0...500 Ω				–	0...500 Ω	–
	loading capability when used as voltage output	Max. ±10 mA				–	Max. ±10 mA	–
<b>Process voltage UP</b>								
Nominal voltage		24 V DC						
Current consumption on UP								
	Min. (module alone)	0.150 A					0.130 A	
	Max. (min. + loads)	0.150 A + load	0.150 A + load		–	0.150 A + load		
Reverse polarity protection		●	●	●	●	●	●	
Max. line length of the analog lines, conductor cross section > 0.14 mm <sup>2</sup>		100 m						
Conversion error of analog values caused by non-linearity, calibration errors ex works and the resolution in the nominal range		0.5 % typically, 1 % max.					Voltage: 0.1 % typically, current/resistor 0.3 % typically	
<b>Potential isolation</b>								
Per module		●	●	●	●	●	–	
Fieldbus connection		Via AC500-XC CPU or all communication interface modules (except DC505-FBP)						
Voltage supply for the module		Internally via extension bus interface (I/O bus)						

## AC500-XC

### Technical data

#### CD522-XC encoder module

The CD522-XC module offers accuracy and dynamic flexibility for a customized solution. It has two independent encoder inputs onboard and is easily configured using the Automation Builder software for 10 different operation modes and for frequencies up to 300 kHz. The CD522-XC module also integrates outputs for pulses and for PWM as well as normal inputs and outputs, depending on selected encoder mode.

Type		CD522-XC
<b>Functionality</b>		
Digital inputs/outputs		24 V DC, dedicated inputs/outputs can be used for specific counting functions. All unused inputs/outputs can be used as input/output with standard specification.
	Input options	Catch/Touch operation, counter value stored in separate variable on external event (rising or falling) Set to preset counter register with predefined value Set to reset counter register
	End value output	Output set when predefined value is reached
	Reference point initialization (RPI) input for relative encoder initialization	●
High-speed counter/encoder		
Integrated counters	Counter characteristics	2 counters (24 V DC, 5 V DC, differential and 1 Vpp sinus input)
	Counter mode	one 32 bits or two 16 bits
	Relative position encoder	X1, X2, X3
	Absolute SSI encoder	●
	Time frequency meter	●
	Frequency input	up to 300 kHz
PWM/pulse outputs		
Output mode specification	Number of outputs	2
	Push pull output	24 V DC, 100 mA max
	Current limitation	Thermal and overcurrent
PWM mode specification	Frequency	1...100 kHz
	Value	0...100 %
Pulse mode specification	Frequency	1...15 kHz
	Pulse emission	1...65535 pulses
	Number of pulses emitted indicator	0...100 %
Frequency mode specification	Frequency output	100 kHz
	Duty Cycle	Set to 50 %
<b>Number of channels per module</b>		
Digital	input	2
	output	2
Configurable channels DC (configurable as inputs or outputs)		8
<b>Additional configuration of channels as</b>		
Fast counter		Integrated 2 counter encoders
Connection via terminal unit		●
<b>Digital Inputs</b>		
Input	signal voltage	24 V DC
	time delay	8 ms typically configurable from 0.1 up to 32 ms
<b>Input current per channel</b>		
At input voltage	24 V DC	Typically 5 mA
	5 V DC	> 1 mA
	15 V DC	> 5 mA
	30 V DC	< 8 mA

## AC500-XC

### Technical data

#### CD522-XC encoder module

Type	CD522-XC	
<b>Digital outputs</b>		
Output voltage at signal state 1	UP – 0.8 V	
<b>Output current</b>		
Nominal current per channel	0.5 A	
Maximum (total current of all channels)	8 A	
Residual current at signal state 0	< 0.5 mA	
Demagnetization when switching off inductive loads	By internal varistors	
<b>Switching frequency</b>		
For inductive load	Max. 0.5 Hz	
For lamp load	Max. 11 Hz with max. 5 W	
Short-circuit / Overload proofness	●	
Overload indication (I > 0.7 A)	After approx. 100 ms	
Output current limiting	●	
Proofness against reverse feeding of 24 V signals	●	
<b>Maximum cable length for connected process signals</b>		
Cable	shielded	1000 m
	unshielded	600 m
<b>Potential isolation</b>		
Per module	●	
<b>Technical data of the high-speed inputs</b>		
Number of channels per module	6	
Input type	24 V DC, 5 V DC / Differential / Sinus 1 Vpp	
Frequency	300 kHz	
<b>Technical data of the fast outputs</b>		
Number of channels	2	
Indication of the output signals	Brightness of the LED depends on the number of pulses emitted (0 % to 100 %) (pulse output mode only)	
<b>Output current</b>		
Rated value, per channel	100 mA at UP = 24 V	
Maximum value (all channels together, configurable outputs included)	8 A	
Leakage current with signal 0	< 0.5 mA	
Rated protection fuse on UP	10 A fast	
De-magnetization when inductive loads are switched off	with varistors integrated in the module	
Overload message (I > 0.1 x A)	Yes, after ca. 100 ms	
Output current limitation	Yes, automatic reactivation after short-circuit/overload	
Resistance to feedback against 24 V signals	Yes	
<b>Process voltage UP</b>		
Nominal voltage	24 V DC	
Current consumption on UP		
Min. (module alone)	0.070 A	
Max. (min. + loads)	0.070 A + load	
Reverse polarity protection	●	
Fuse for process voltage UP	10 A miniature fuse	

## AC500-XC

### Technical data

#### Analog/digital mixed I/O extension module

For all modules: max cable length for connected process signals is 1000 m for shielded cable and 600 m for unshielded ones. For all Input modules, the signal resolution for channel configuration is: -10...+10 V: 12 bit + sign; 0...10 V, 0...20 mA, 4...20 mA: 12 bits.

Type	DA501-XC	DA502-XC
<b>Number of Channels per Module</b>		
Digital		
inputs	16	–
outputs	–	16
Analog		
inputs	4	4
outputs	2	2
Digital configurable channels DC (configurable as inputs or outputs)	8	8
<b>Additional configuration of channels as</b>		
Fast counter	Yes	
Occupies max. 1 DO or DC when used as counter	Configuration of max. 2 channels per module. Operating modes see table on page 192	
Connection via terminal unit TU 5xx	●	
<b>Digital inputs</b>		
Input	signal voltage	24 V DC
	characteristic acc. to EN 61132-2	Type 1
0 signal		-3...+5 V DC
Undefined signal state		5...15 V DC
1 signal		15...30 V DC
Residual ripple, range for	0 signal	-3...+5 V DC
	1 signal	15...30 V DC
Input time delay (0 -> 1 or 1 -> 0)	8 ms typically, configurable from 0.1 up to 32 ms	
<b>Digital outputs</b>		
Transistor outputs 24 V DC, 0.5 A	●	
Readback of output	●	
Outputs, supplied via process voltage UP	●	
Switching of 24 V load	●	
Output voltage at signal state 1	Process voltage UP - 0.8 V	
<b>Output current</b>		
Nominal current per channel	500 mA at UP = 24 V DC	
Maximum (total current of all channels)	4 A	8 A
Residual current at signal state 0	< 0.5 mA	
Demagnetization when switching off inductive loads	By internal varistors	
<b>Analog inputs AI</b>	Max. number per module and with regard to the configuration: AIs / Measuring points	
Signal configuration per AI	●	
0...10 V / -10 ... +10 V	4 / 4	
0...20 mA / 4...20 mA	4 / 4	
RTD using 2/3 wire needs 1/2 channel(s)	4 / 2	
0...10 V using differential inputs, needs 2 channels	4 / 2	
-10...+10 V using differential inputs, needs 2 channels	4 / 2	
Digital signals (digital input)	4 / 4	
<b>Data when using the AI as digital input</b>		
Input	time delay	8 ms typically, configurable from 0.1 up to 32 ms
	signal voltage	24 V DC
<b>Outputs, single configurable as</b>		
Possible configuration per AO	●	
-10...+10 V	●	
0...20 mA / 4...20 mA	●	
Output resistance (load) when used as current output	0...500 Ω	
Output loading capability when used as voltage output	±10 mA max.	
<b>Potential isolation</b>		
Per module	●	

## AC500-XC

### Technical data

#### Analog/digital mixed I/O extension module

Type	DA501-XC	DA502-XC
<b>Process voltage UP</b>		
Nominal voltage	24 V DC	
Current consumption on UP		
Min. (module alone)	0.070 A	
Max. (min. + loads)	0.070 A + load	
Reverse polarity protection	●	
Fuse for process voltage UP	10 A miniature fuse	
<b>Approvals</b>	See detailed page 272 or <a href="http://www.abb.com/plc">www.abb.com/plc</a>	

## AC500-XC

### Technical data

#### DC541-CM-XC interrupt I/O and fast counter module

In the operating mode counter, the channels can be configured as follows:

Input, Output, 32-bit up/down counter (uses C0...C3) as a 32-bit counter without limit, 32-bit periodic counter as a 32-bit counter with a limit, limiter for a 32-bit counter (limit channel 0), 32-bit up counter (forward counter) with the frequencies 50 kHz, 5 kHz and 2.5 kHz, pulse-width modulation (PWM) with a resolution of 10 kHz, time and frequency measurement, frequency output.

Type	DC541-CM-XC	
<b>Number of channels per module</b>		
Configurable channels DC (configurable as inputs or outputs)	8	
<b>Additional configuration of channels as</b>		
Fast counter	Yes	
Connection via CPU terminal base. Occupies one communication module slot	●	
<b>Digital inputs</b>		
Input signal voltage	24 V DC	
characteristic acc. to EN 61132-2	Type 1	
0 signal	-3...+5 V DC	
Undefined signal state	5...15 V DC	
1 signal	5...30 V DC	
Input time delay (0 -> 1 or 1 -> 0)	20 μs	
	Clamp to clamp - 300 μs with interrupt task	
<b>Input current per channel</b>		
At input voltage	24 V DC	5 mA typically
	5 V DC	> 1 mA
	15 V DC	> 5 mA
	30 V DC	< 8 mA
<b>Digital outputs</b>		
Transistor outputs 24 V DC, 0.5 A	●	
Readback of output	●	
Switching of 24 V load	●	
Output voltage at signal state 1	Process voltage UP minus 0.8 V	
<b>Output current</b>		
Nominal current per channel	500 mA at UP = 24 V	
Maximum (total current of all channels)	4 A	
Residual current at signal state 0	< 0.5 mA	
Demagnetization when switching off inductive loads	by internal varistors	
<b>Potential isolation</b>		
Per module	●	
Voltage supply for the module	Internally via backplane bus	

#### Interrupt I/O table

Configuration as	Configuration for channel no.					Max. no. of channels for this function	Remarks and notes regarding possible alternative combinations of the remaining channels (a and b)	
	Chan. 0	Chan. 1	Chan. 2	Chan. 3	Chan. 4-7			
<b>Mode 1: Interrupt functionality</b>								
Interrupt	Digital input	1	1	1	1	4	8	Each channel can be configured individually as interrupt input or output
	Digital output	1	1	1	1	4	8	
<b>Mode 2: Counting functionality</b>								
Digital I/Os	Digital input	1	1	1	1	4	8	Usual input
PWM (1)	Digital output	1	1	1	1	4	8	Usual output
	PWM, resolution 10 kHz	1	1	1	1	4	8	Outputs and pulsed signal with and adjustable on-off ratio

(1) Counter and fast counter data available on technical documentation.



## AC500-XC

### Technical data

#### AC500 Condition Monitoring CMS: FM502-CMS-XC

The FM502-CMS-XC function module offers precision and dynamic flexibility for customized solutions in condition monitoring, precise measurement or fast data logging applications. It has 16 fast, precise and synchronized analog inputs with 50k Samples/s (SPS), 24bit ADC resolution, completed with encoder inputs (incremental or absolute) with counter and additional DI and DC inputs/outputs on-board. It is easily configured using the Automation Builder software and the special libraries. Overall it has 12 different operation modes. One FM502 function module can be placed on the right side of PM592-ETH-XC CPU with a special function module terminal base TF5x1, to interface directly to the CPU. While long measurements can be flexibly configured, started and stopped, all inputs are available in the I/O Image of CPU for immediate use (measurement, protection, control, ...)

Type	FM502-CMS-XC	
<b>Data storage</b>		
Fast user data memory of FM502	128 MB (ca. 33 million Samples: e.g 40 s record length on 16 channels at 50k SPS or 5.8 h record length on 16 channels at 100 SPS)	
File Format delivered to PM592 flash	WAV (compact binary) per channel, all channels in one *.zip w. time stamp	
<b>Analog inputs</b>		
Number of channels	16 (synchronous sampled)	
Resolution	24 bit ADC, stored in DINT in WAV file (4byte per value)	
Accuracy at +25 °C	< +/- 0.1 %	
Accuracy over operating temperature and vibration	< +/- 0.5 %	
Sample rate / Bandwidth (High, 0 dB)	50k SPS / 20 kHz to 100 SPS / 40 Hz (digitally downsampled, selectable per channel)	
Indication of the input signal	One bicolor LED per channel for configuration, measurement status, error messages	
<b>Input option:</b>	<b>IEPE (with Sensor supply current)</b>	<b>+ - 10 V</b>
Bandwidth low (- 3 dB)	digital < 0.1 Hz	digital < 0.1 Hz or DC (selectable)
Pass band high (- 3 dB)	analog > 90 kHz, digital > 24.5 kHz	
Stop band high (> - 100 dB)	analog > 1 MHz, digital > 27.5 kHz	
Dynamic Range (SFDR)	> 100 dB	
SINAD (300 Hz/1 kHz sine, 50 k SPS) 0dB from full scale	< -90 dB	< - 95 dB
IEPE Current Source per channel	Typ. 4.2 mA (+/- 7 % over temperature)	(n.a.)
Resistance AI- to M (ground)	Typ ~ 270hm (PTC)	
<b>Channel input impedance (AI+/AI-):</b>		
< 1 kHz	> 1 MOhm	> 2 MOhm
5 kHz	> 100 kOhm	> 40 kOhm
10 kHz	> 60 kOhm	> 25 kOhm
20 kHz	> 40 kOhm	> 8 kOhm
Error detection	Short circuit, open wire	
Max. cable length, shielded (depending on sensor)	100 m	
<b>Digital inputs/outputs</b>		
	24 V DC, dedicated inputs/outputs can be used for specific counting functions.	
	All unused inputs/outputs can be used as normal input/output with standard specification.	
Channels and types	2 DI + 2 DC (configurable inputs/outputs); Type 1, LED indication	
Input options	Catch/Touch operation, counter value stored in separate variable on external event (rising or falling)	
	Set to preset counter register with predefined value	
	Set to reset counter register	
End value output	Output set when predefined value is reached	
Reference point initialization (RPI) input for relative encoder initialization	●	
<b>Input current p. channel @ V DC</b>		
24 V DC	Typically 5 mA	
5 V DC	> 1 mA	
15 V DC	> 5 mA	
30 V DC	< 8 mA	

## AC500-XC

### Technical data

#### AC500 Condition Monitoring CMS: FM502-CMS-XC

Type	FM502-CMS-XC	
<b>Digital outputs</b>		
Output voltage at signal state 1	(L+) – 0.8 V	
<b>Output current</b>		
Nominal current per channel	0.5 A at UP = 24 V	
Residual current at signal state 0	< 0.5 mA	
Demagnetization when switching off inductive loads	By internal varistors	
<b>Switching frequency</b>		
For inductive load	Max. 0.5 Hz	
For lamp load	Max. 11 Hz with max. 5 W	
Short-circuit / Overload proofness	•	
Overload indication (I > 0.7 A)	After approx. 100 ms	
Output current limiting	•	
Resistance against reverse feeding of 24 V signals	•	
<b>Maximum cable length for connected process signals</b>		
shielded	1000 m	
unshielded	600 m	
<b>High-speed counter/encoder</b>		
<b>Integrated counters</b>		
Counter characteristics	2 counters (24 V DC, 5 V DC, differential RS422: 5 V or 1 Vpp sinus input)	
Counter mode	one counter 32 bits or two counters 16 bits	
Relative position encoder	X1, X2, X3	
Absolute SSI encoder	•	
Time frequency meter	•	
Frequency input	up to 300 kHz	
<b>Additional configuration of channels as</b>		
Fast counter	Integrated 2 counter encoders	
<b>high-speed inputs</b>		
Number of channels, type per module	3 (A,B,Z), type 1	
Input type	24 V DC	5 V DC / Differential / Sinus 1 Vpp
Frequency	up to 300 kHz (input filter: 50,500, 5 k, 20 k Hz)	
Input frequency max. (frequency measurement only)	100 kHz (accuracy -0 %/+3 %)	
Max. cable length, shielded (depending on sensor)	300 m	100 m
<b>Fast outputs</b>		
SSI CLK output B	f. optical Interface (according SSI): Pin 1.3	RS-422 differential (according SSI) Pins 1.3, 1.4
Output delay (0->1 or 1->0)	Max. 0.35 µs	
Output current	≤ 10 mA	
Switching frequency (selectable)	200kHz, 500kHz and 1 MHz	
Short-circuit proof / overload proof	Yes	
Output current limitation	Yes, automatic reactivation after short-circuit/overload	
Resistance to feedback against 24V signals	Yes	
Resistance to feedback against reverse polarity	Yes	
Max. cable length, shielded (depending on sensor)	100 m	
<b>Process voltage L+</b>		
Nominal voltage	24 V DC	
Max. ripple	0,05	
Current consumption from L+ (FM502 and PM592, no communication module)	Max. 0.43 A + max. 0.5 A per output	
Inrush current from L+ (at power up, FM502 and PM592, no communication module)	1.2 A <sup>2</sup> s	
Electrical isolation	Yes, (PM592 and FM502 to other I/O-Bus modules )	
Max. power dissipation within the FM502 module	6.5 W (outputs unloaded)	
<b>5-V-encoder supply output</b>		
Nominal voltage	5 V DC (+/- 5 %), 100 mA max.	

(1) High Temperatures:

Operation of FM502-XC version in the operating temperature range between +60 °C and +70 °C with following deratings:

No use of 24 V encoder mode

Analog inputs: maximum number of configured input channels limited to 75 % per group AI0..AI7 and AI8..AI15

## AC500-XC

### Technical data

#### AC500-XC communication modules

- Up to 4 communications modules can be used on an AC500-XC CPU, up to 6 on AC500-XC V3 CPU.
- No external power supply required.

Type	CM592-DP-XC	CM582-DP-XC	CM597-ETH-XC	CM598-CN-XC
<b>AC500-XC V3 support</b>	(3)	(3)	–	(4)
<b>Communication interfaces</b>				
RJ45	–	–	● (x2) (2)	–
RS-232 / 485	–	–	–	–
Terminal blocks (1)	–	–	–	●
Sub-D socket	●	●	–	–
<b>Protocols</b>	PROFIBUS DP V0/V1 master	PROFIBUS DP V0/V1 slave	Ethernet (TCP/IP, UDP/IP, Modbus TCP)	CANopen master
<b>CPU interface</b>	8 kB Dual-port memory	8 kB Dual-port memory	8 kB Dual-port memory	8 kB Dual-port memory
Transfer Rate	9.6 kbit/s to 12 Mbit/s	9.6 kbit/s to 12 Mbit/s	10/100 Mbit/s	10 kbit/s to 1 Mbit/s
Co-processor				
Additional features	Multi master functionality Max. Number of subscribers: - 126 (V0) - 32 (V1)	–	Online Access, ICMP (Pimg), DHCP, IP configuration protocol, UDP dataexchange, Modbus TCP	CAN 2.0A CAN 2.0B CANopen

Type	CM588-CN-XC	CM579-PNIO-XC	CM589-PNIO-XC	CM589-PNIO-4-XC
<b>AC500-XC V3 support</b>	–	●	(3)	(3)
<b>Communication interfaces</b>				
RJ45	–	● (x2) (2)	● (x2) (2)	● (x2) (2)
RS-232 / 485	–	–	–	–
Terminal blocks (1)	●	–	–	–
Sub-D socket	–	–	–	–
<b>Protocols</b>	CANopen slave	PROFINET IO controller	PROFINET IO device	PROFINET IO 4 x device
<b>CPU interface</b>	8 kB Dual-port memory	8 kB Dual-port memory	8 kB Dual-port memory	8 kB Dual-port memory
Transfer Rate	10 kbit/s to 1 Mbit/s	10/100 Mbit/s	10/100 Mbit/s	10/100 Mbit/s
Co-processor				
Additional features	NMT slave, PDO, SDO server, Heartbeat, Nodeguard	RTC - Real-Time Cyclic Protocol, Class 1 RTA - Real-Time Acyclic Protocol DCP Discovery and Configuration Protocol CL-RPC - Connectionless Remote Procedure Call	RTC - Real-Time Cyclic Protocol, Class 1 RTA - Real-Time Acyclic Protocol DCP Discovery and Configuration Protocol LLDP - Link Layer Discovery Protocol	RTC - Real-Time Cyclic Protocol, Class 1 RTA - Real-Time Acyclic Protocol DCP Discovery and Configuration Protocol LLDP - Link Layer Discovery Protocol

(1) Plug-in terminal block included.

(2) 10/100 Mbit/s, full/half duplex with auto-sensing, 2-port switch integrated.

(3) In preparation

(4) Only with CAN 2A/2B today

## AC500-XC

### Technical data

#### Communication interface modules

For all modules: max cable length for connected process signals is 1000 m for shielded cable and 600 m for unshielded ones. For all Input modules, the signal resolution for channel configuration is: -10...+10 V: 12 bits + sign; 0...10 V, 0...20 mA, 4...20 mA: 12 bits. Temperature: 0.1 °C.

Type	DC551-CS31-XC	CI590-CS31-HA-XC (1)	CI592-CS31-XC
<b>Communication Interface</b>			
Protocol	Proprietary CS31 bus protocol on RS485 interface		
ID configuration	Per rotary switches on front face from 00d to 99d		
Field bus connection on TUs	CS31 field bus, via terminal / redundant for CI590-CS31-HA-XC on TU552-CS31-XC		
<b>Number of Channels per Module</b>			
Digital	inputs	8	8
	outputs	-	-
Analog	inputs	-	4
	outputs	-	2
Digital configurable channels DC (configurable as inputs or outputs)	16	16	8
<b>Additional configuration of channels as</b>			
Fast counter	Configuration of max. 2 channels per module		
Occupies max. 1 DO or DC when used as counter	●	●	●
<b>Connection</b>			
Via terminal base TU5xx	●	●	●
<b>Local I/O extension</b>			
Max. number of extension modules	max. 7 x S500 extension modules, up to 31 stations with up to 120 DI/120 DOs or up to 32 AIs/ 32AOs per station		
<b>Digital inputs</b>			
Input	signal voltage	24 V DC	
	characteristic acc. to EN 61132-2	Type 1	
0 signal	-3...+5 V DC		
Undefined signal state	5...15 V DC		
1 signal	15...30 V DC		
Residual ripple, range for	0 signal	-3...+5 V DC	
	1 signal	15...30 V DC	
Input time delay (0 -> 1 or 1 -> 0)	8 ms typically, configurable from 0.1 up to 32 ms		
<b>Digital outputs</b>			
Transistor outputs 24 V DC, 0.5 A	●		
Readback of output	●		
Outputs, supplied via process voltage UP	●		
Switching of 24 V load	●		
Output voltage at signal state 1	Process voltage UP - 0.8 V		
<b>Output current</b>			
Nominal current per channel	500 mA at UP = 24 V DC		
Maximum (total current of all channels)	8 A	8 A	4 A
Residual current at signal state 0	< 0.5 mA		
Demagnetization when switching off inductive loads	By internal varistors		
<b>Analog inputs AI</b>			
Signal configuration per AI	-	●	
0...10 V / -10...+10 V	-	4 / 4	
0...20 mA / 4...20 mA	-	4 / 4	
RTD using 2/3 wire needs 1/2 channel(s)	-	4 / 2	
0...10 V using differential inputs, needs 2 channels	-	4 / 2	
-10...+10 V using differential inputs, needs 2 channels	-	4 / 2	
Digital signals (digital input)	-	4 / 4	

(1) Dedicated to High Availability. Not compatible with S500-eCo I/O modules.

## AC500-XC

### Technical data

#### Communication interface modules

Type		DC551-CS31-XC	CI590-CS31-HA-XC (1)	CI592-CS31-XC
<b>Data when using the AI as digital input</b>				
Input	time delay	–		8 ms typically, configurable from 0.1 up to 32 ms
	signal voltage	–		24 V DC
<b>Outputs, single configurable as</b>				
Possible configuration per AO		–		●
-10...+10 V		–		●
0...20 mA / 4...20 mA		–		●
Output	resistance (load) when used as current output	–		0...500 Ω
	loading capability when used as voltage output	–		±10 mA max.
<b>Potential isolation</b>				
Per module		●	●	●
Between fieldbus interface against the rest of the module		●	●	●
Voltage supply for the module		By external 24 V DC voltage via terminal UP		
<b>Process voltage UP</b>				
Nominal voltage		24 V DC		
Current consumption on UP				
Min. (module alone)		0.100 A	0.100 A	0.070 A
Max. (min. + loads)		0.100 A + load	0.100 A + load	0.070 A + load
Reverse polarity protection		●		
Fuse for process voltage UP		10 A miniature fuse		
<b>Approvals</b>		See detailed page 272 or <a href="http://www.abb.com/plc">www.abb.com/plc</a>		

(1) Dedicated to High Availability. Not compatible with S500-eCo I/O modules.

## AC500-XC

### Technical data

#### PROFIBUS-DP modules

Type	CI541-DP-XC	CI542-DP-XC	
<b>Communication Interface</b>			
Protocol	PROFIBUS DP (DP-V0 and DP-V1 slave)		
ID configuration	Per rotary switches on front face from 00h to FFh		
Field bus connection on terminal units	Sub-D 9 poles on TU510-XC or TU518-XC with baud rate up to 1MBaud		
<b>Number of Channels per Module</b>			
Digital	inputs	8	8
	outputs	8	8
Analog	inputs	4	-
	outputs	2	-
Digital configurable channels DC (configurable as inputs or outputs)	-	-	8
<b>Additional configuration of channels as</b>			
Fast counter (onboard I/O)	Configuration of max. 2 DI channels per module		
Occupies max 1 DO or DC when used as counter	•	•	
<b>Connection</b>			
Local I/O extension	•		
Max. number of extension modules	max. 10 x S500 extension modules, fast counter from digital I/O modules can be also used		
Via terminal base TU5xx	•		
<b>Digital inputs</b>			
Input	signal voltage	24 V DC	
	characteristic acc. to EN 61132-2	Type 1	
0 signal	-3...+5 V DC		
Undefined signal state	5...15 V DC		
1 signal	15...30 V DC		
Residual ripple, range for	0 signal	-3...+5 V DC	
	1 signal	15...30 V DC	
Input time delay (0 -> 1 or 1 -> 0)	8 ms typically, configurable from 0.1 up to 32 ms		
<b>Digital outputs</b>			
Transistor outputs 24 V DC, 0.5 A	•		
Readback of output	-	• (on DC outputs)	
Outputs, supplied via process voltage UP	•		
Switching of 24 V load	•		
Output voltage at signal state 1	Process voltage UP - 0.8 V		
<b>Output current</b>			
Nominal current per channel	500 mA at UP = 24 V DC		
Maximum (total current of all channels)	8 A		
Residual current at signal state 0	< 0.5 mA		
Demagnetization when switching off inductive loads	By internal varistors		
<b>Analog Inputs AI</b>			
	Max. number per module and with regard to the configuration: AIs / Measuring points		
Signal configuration per AI	4	-	
0...10 V / -10...+10 V	4 / 4	-	
0...20 mA / 4...20 mA	4 / 4	-	
RTD using 2/3 wire needs 1/2 channel(s)	4 / 2	-	
0...10 V using differential inputs, needs 2 channels	4 / 2	-	
-10...+10 V using differential inputs, needs 2 channels	4 / 2	-	
Digital signals (digital input)	4 / 4	-	
<b>Data when using the AI as digital input</b>			
Input	time delay	8 ms typically, configurable from 0.1 up to 32 ms	-
	signal voltage	24 V DC	-

## AC500-XC

### Technical data

#### PROFIBUS-DP modules

Type	CI541-DP-XC	CI542-DP-XC
<b>Outputs, single configurable as</b>		
Possible configuration per AO	•	-
-10...+10V	•	-
0...20 mA / 4...20 mA	•	-
Output resistance (load) when used as current output	0...500 Ω	-
loading capability when used as voltage output	±10 mA max.	-
<b>Potential isolation</b>		
Per module	•	•
Between fieldbus interface against the rest of the module	•	•
Between the channels		
input	-	-
output	-	-
Voltage supply for the module	By external 24 V DC voltage via terminal UP	
<b>Process voltage UP</b>		
Nominal voltage	24 V DC	
Current consumption on UP		
Min. (module alone)	0.260 A	
Max. (min. + loads)	0.260 A + load	
Reverse polarity protection	•	
Fuse for process voltage UP	10 A miniature fuse	
Approvals	See detailed page 272 or <a href="http://www.abb.com/plc">www.abb.com/plc</a>	



## AC500-XC

### Technical data

#### CANopen modules

Type	CI581-CN-XC	CI582-CN-XC
<b>Communication interface</b>		
Protocol	CANopen slave, DS401 profile selectable using rotary switches	
ID configuration	Per rotary switches on front face for CANopen ID node from 00h to 7Fh and 80h to FFh for CANopen DS401 profile	
Field bus connection on terminal units	Terminal blocks on TU518-XC	
<b>Number of channels per module</b>		
Digital	inputs	8
	outputs	8
Analog	inputs	4
	outputs	2
Digital configurable channels DC (configurable as inputs or outputs)	–	8
<b>Additional configuration of channels as</b>		
Fast counter (onboard I/O)	Configuration of max. 2 DI channels per module	
Occupies max. 1 DO or DC when used as counter	●	●
<b>Connection</b>		
Local I/O extension	●	
Max. number of extension modules	max. 10 x S500-XC extension modules	
Via terminal unit TU5xx	●	●
<b>Digital inputs</b>		
Input	signal voltage	24 V DC
	characteristic acc. to EN 61132-2	Type 1
0 signal	-3...+5 V DC	
Undefined signal state	5...15 V DC	
1 signal	15...30 V DC	
Residual ripple, range for	0 signal	-3...+5 V DC
	1 signal	15...30 V DC
Input time delay (0 -> 1 or 1 -> 0)	8 ms typically, configurable from 0.1 up to 32 ms	
<b>Digital outputs</b>		
Transistor outputs 24 V DC, 0.5 A	●	
Readback of output	–	● (on DC outputs)
Outputs, supplied via process voltage UP	●	
Switching of 24 V load	●	
Output voltage at signal state 1	Process voltage UP - 0.8 V	
<b>Output current</b>		
Nominal current per channel	500 mA at UP = 24 V DC	
Maximum (total current of all channels)	8 A	
Residual current at signal state 0	< 0.5 mA	
Demagnetization when switching off inductive loads	By internal varistors	
<b>Analog Inputs AI</b>		
Max. number per module and with regard to the configuration: AIs / Measuring points		
Signal configuration per AI	4	–
0...10 V / -10...+10 V	4 / 4	–
0...20 mA / 4...20 mA	4 / 4	–
RTD using 2/3 wire needs 1/2 channel(s)	4 / 2	–
0...10 V using differential inputs, needs 2 channels	4 / 2	–
-10...+10 V using differential inputs, needs 2 channels	4 / 2	–
Digital signals (digital input)	4 / 4	–
<b>Data when using the AI as digital input</b>		
Input	time delay	8 ms typically, configurable from 0.1 up to 32 ms
	signal voltage	24 V DC

## AC500-XC

### Technical data

#### CANopen modules

Type	CI581-CN-XC	CI582-CN-XC
<b>Outputs, single configurable as</b>		
Possible configuration per AO	●	-
-10...+10 V	●	-
0...20 mA / 4...20 mA	●	-
Output	resistance (load) when used as current output	0...500 Ω
	loading capability when used as voltage output	±10 mA max.
<b>Potential isolation</b>		
Per module	●	●
Between fieldbus interface against the rest of the module	●	●
Between the channels	input	-
	output	-
Voltage supply for the module	By external 24 V DC voltage via terminal UP	
<b>Process voltage UP</b>		
Nominal voltage	24 V DC	
Current consumption on UP		
	Min. (module alone)	0.260 A
	Max. (min. + loads)	0.260 A + load
Reverse polarity protection	●	
Fuse for process voltage UP	10 A miniature fuse	
<b>Approvals</b>	See detailed page 272 or <a href="http://www.abb.com/plc">www.abb.com/plc</a>	

# AC500-XC

## Technical data

### PROFINET IO RT device modules

Type	CI501-PNIO-XC	CI502-PNIO-XC	CI504-PNIO-XC	CI506-PNIO-XC
<b>Communication interface</b>				
Ethernet Interface				
Main protocol	PROFINET IO RT device			
ID Device configuration	By rotary switch on the front side, from 00h to FFh			
Ethernet connection on terminal units	2 x RJ45 with switch functionality for simple daisy chain on TU508-ETH-XC or TU520-ETH-XC			
Gateway Interface				
Gateway to	-	-	3 x RS232/RS422/ RS485 ASCII serial interfaces	CAN / CANopen Master + 2 x RS232/RS422/ RS485 ASCII serial interfaces
Fieldbus Protocol used				
CAN physical interface	-	-	-	CAN 2A/2B Master - CANopen Master (1)
Baudrate	-	-	-	Baudrate up to 1 MBit/s, Support for up to 126 CANopen Slaves
Serial interface				
Protocol used	-	-	3 x RS232 / RS422 or RS485	2 x RS232 / RS422 or RS485
Baudrate	-	-	Configurable from 300 bit/s to 115200 bit/s	
Fieldbus or serial connection on TUs	-	-	3 x pluggable terminal blocks with spring on TU520-ETH	
<b>Number of channels per module</b>				
Digital	inputs	8	8	-
	outputs	8	8	-
Analog	inputs	4	-	-
	outputs	2	-	-
Digital configurable channels DC (configurable as inputs or outputs)		-	8	-
<b>Additional configuration of channels as</b>				
Connection via terminal unit TU5xx		-	-	● ●
Fast counter (onboard I/O)		Configuration of max. 2 DI channels per module		-
Occupies max. 1 DO or DC when used as counter		●	-	-
<b>Connection</b>				
Local I/O extension		●	-	●
Max. number of extension modules		max. 10 x S500-XC extension modules. Fast counter from digital I/O modules can be also used.		Valid for CI501-XC, 502-XC, 504-XC and 506-XC. All modules can have extension up to 10 modules
<b>Digital inputs</b>				
Input	signal voltage	24 V DC		-
	characteristic acc. to EN 61132-2	Type 1		-
0 signal		-3...+5 V DC		-
Undefined signal state		5...15 V DC		-
1 signal		15...30 V DC		-
Residual ripple, range for	0 signal	-3...+5 V DC		-
	1 signal	15...30 V DC		-
Input time delay (0 -> 1 or 1 -> 0)		8 ms typically, configurable from 0.1 up to 32 ms		-
<b>Digital outputs</b>				
Transistor outputs 24 V DC, 0.5 A		●	-	-
Readback of output		-	● (on DC outputs)	-
Outputs, supplied via process voltage UP		●	-	-
Switching of 24 V load		●	-	-
Output voltage at signal state 1		Process voltage UP - 0.8 V		-

(1) Not simultaneously.

## AC500-XC

### Technical data

#### PROFINET IO RT device modules

Type	CI501-PNIO-XC	CI502-PNIO-XC	CI504-PNIO-XC	CI506-PNIO-XC
<b>Output current</b>				
Nominal current per channel	500 mA at UP = 24 V DC		–	–
Maximum (total current of all channels)	8 A		–	–
Residual current at signal state 0	< 0.5 mA		–	–
Demagnetization when switching off inductive loads	By internal varistors		–	–
<b>Analog inputs AI</b>				
	Max. number per module and with regard to the configuration: AIs / Measuring points			
Signal configuration per AI	4	–	–	–
0...10 V / -10... +10 V	4 / 4	–	–	–
0...20 mA / 4...20 mA	4 / 4	–	–	–
RTD using 2/3 wire needs 1/2 channel(s)	4 / 2	–	–	–
0...10 V using differential inputs, needs 2 channels	4 / 2	–	–	–
-10...+10 V using differential inputs, needs 2 channels	4 / 2	–	–	–
Digital signals (digital input)	4 / 4	–	–	–
<b>Data when using the AI as digital input</b>				
Input	time delay	8 ms typically, configurable from 0.1 up to 32 ms	–	–
	signal voltage	24 V DC	–	–
<b>Outputs, single configurable as</b>				
Possible configuration per AO		●	–	–
-10...+10 V		●	–	–
0...20 mA / 4...20 mA		●	–	–
Output	resistance (load) when used as current output	0...500 Ω	–	–
	loading capability when used as voltage output	±10 mA max.	–	–
<b>Potential isolation</b>				
Per module		●	●	●
Between Ethernet interface against the rest of the module		●	●	●
Voltage supply for the module		By external 24 V DC voltage via terminal UP		
<b>Process voltage UP</b>				
Nominal voltage		24 V DC		
Current consumption on UP				
min. (module alone)		0.260 A		0.150 A
max. (min. + loads)		0.260 A + load		0.150 A + load
Reverse polarity protection		●		
Fuse for process voltage UP		10 A miniature fuse		
<b>Approvals</b>		See detailed page 272 or <a href="http://www.abb.com/plc">www.abb.com/plc</a>		

(1) Not simultaneously.

## AC500-XC

### Technical data

#### Modbus TCP modules

Type	CI521-MODTCP-XC	CI522-MODTCP-XC	
<b>Communication interface</b>			
Ethernet Interface			
Main protocol	Modbus TCP		
ID Device configuration	By rotary switch on the front side, from 00h to FFh		
Ethernet connection on terminal units	2 x RJ45 with switch functionality for simple daisy chain on TU508-ETH-XC or TU520-ETH-XC		
<b>Number of channels per module</b>			
Digital	inputs	8	8
	outputs	8	8
Analog	inputs	4	-
	outputs	2	-
Digital configurable channels DC (configurable as inputs or outputs)		-	8
<b>Additional configuration of channels as</b>			
Connection via terminal unit TU5xx	-	-	
Fast counter (onboard I/O)	Configuration of max. 2 DI channels per module		
Occupies max. 1 DO or DC when used as counter	●		
<b>Connection</b>			
Local I/O extension	●		
Max. number of extension modules	max. 10 x S500-XC extension modules. Fast counter from digital I/O modules can be also used.		
<b>Digital inputs</b>			
Input	signal voltage	24 V DC	
	characteristic acc. to EN 61132-2	Type 1	
0 signal	-3...+5 V DC		
Undefined signal state	5...15 V DC		
1 signal	15...30 V DC		
Residual ripple, range for	0 signal	-3...+5 V DC	
	1 signal	15...30 V DC	
Input time delay (0 -> 1 or 1 -> 0)	8 ms typically, configurable from 0.1 up to 32 ms		
<b>Digital outputs</b>			
Transistor outputs 24 V DC, 0.5 A	●		
Readback of output	-	● (on DC outputs)	
Outputs, supplied via process voltage UP	●		
Switching of 24 V load	●		
Output voltage at signal state 1	Process voltage UP - 0.8 V		
<b>Output current</b>			
Nominal current per channel	500 mA at UP = 24 V DC		
Maximum (total current of all channels)	8 A		
Residual current at signal state 0	< 0.5 mA		
Demagnetization when switching off inductive loads	By internal varistors		
<b>Analog inputs AI</b>			
Max. number per module and with regard to the configuration: AIs / Measuring points			
Signal configuration per AI	4	-	
0...10 V / -10... +10 V	4 / 4	-	
0...20 mA / 4...20 mA	4 / 4	-	
RTD using 2/3 wire needs 1/2 channel(s)	4 / 2	-	
0...10 V using differential inputs, needs 2 channels	4 / 2	-	
-10...+10 V using differential inputs, needs 2 channels	4 / 2	-	
Digital signals (digital input)	4 / 4	-	

(1) Not simultaneously.

## AC500-XC

### Technical data

#### Modbus TCP modules

Type		CI521-MODTCP-XC	CI522-MODTCP-XC
<b>Data when using the AI as digital input</b>			
Input	time delay	8 ms typically, configurable from 0.1 up to 32 ms	–
	signal voltage	24 V DC	–
<b>Outputs, single configurable as</b>			
Possible configuration per AO		●	–
-10...+10 V		●	–
0...20 mA / 4...20 mA		●	–
Output	resistance (load) when used as current output	0...500 Ω	–
	loading capability when used as voltage output	±10 mA max.	–
<b>Potential isolation</b>			
Per module		●	●
Between Ethernet interface against the rest of the module		●	●
Voltage supply for the module		By external 24 V DC voltage via terminal UP	
<b>Process voltage UP</b>			
Nominal voltage		24 V DC	
Current consumption on UP			
min. (module alone)		0.260 A	
max. (min. + loads)		0.260 A + load	
Reverse polarity protection		●	
Fuse for process voltage UP		10 A miniature fuse	
<b>Approvals</b>		See detailed page 272 or <a href="http://www.abb.com/plc">www.abb.com/plc</a>	

(1) Not simultaneously.

## AC500-XC

### Technical data

#### CS31 functionality

	AC500-XC CPU with integrated CS31 interface	S500 I/O with communication interface DC551-CS31-XC CI590-CS31-HA-XC CI592-CS31-XC
Master	Yes, at COM1	-
Slave	No	Yes / Redundant for CI590-CS31-HA-XC
Protocols supported	ABB CS31 protocol	
<b>Diagnosis</b>		
Error indication	On LCD display of the CPU	Via module LEDs
Online diagnosis	Yes	
Error code	Errors are recorded in the diagnosis system of the CPU	
Associated function blocks	Yes	
<b>Physical layer</b>		
Connection	RS485 / 2 x RS485 for CI590-CS31-HA-XC for redundancy	Screw-type or spring-type terminals
Baud rate	187.5 kbit/s	
Distance	AC500-XC: up to 500 m; up to 2000 m using a repeater	
Max. number of modules on fieldbus	31 modules max. Please note: The CS31 bus interface occupies one or two module addresses (if counters are configured onboard or if the module is a mixed digital analog module). Depending on the configuration, or if the module contains also mixed digital analog I/O, connected extension modules can occupy further module addresses.	
<b>Configuration</b>		
Station address configuration	No	Using rotary switches (99 max.)

#### Digital I/O modules, "Fast Counter" operating modes. Not applicable for DC541-XC (1)

Operating mode, configured in the user program of the AC500-XC	Occupied inputs DI or DC	Occupied outputs DO or DC	Maximum counting frequency kHz
0 No counter	0	0	-
1 One count-up counter with "end value reached" indication	1	1	50
2 One count-up counter with "enable" input and "end value reached" indication	2	1	50
3 Two up/down counters	2	0	50
4 Two up/down counters with 1 counting input inverted	2	0	50
5 One up/down counter with "dynamic set" input	2	0	50
6 One up/down counter with "dynamic set" input	2	0	50
7 One up/down counter with directional discriminator For synchro transmitters using two counting pulses with an offset of 90° (track A and B)	2	0	50
8 -	0	0	-
9 One up/down counter with directional discriminator and double evaluation For synchro transmitters using two counting pulses with an offset of 90° towards each other (track A and B)	2	0	30
10 One up/down counter with directional discriminator and fourfold evaluation For synchro transmitters using two counting pulses with an offset of 90° towards each other (track A and B)	2	0	15

(1) See technical documentation for details.



# AC500-XC

## System data

### Environmental Conditions

#### Process and supply voltages

24 V DC	Voltage	24 V (-15 %, +20 %)
	Protection against reverse polarity	yes
Allowed interruptions of power supply	DC supply	Interruption < 10 ms, time between 2 interruptions > 1 s, PS2
	AC supply	Interruption < 0.5 periods, time between 2 interruptions > 1 s

**Important:** Exceeding the maximum process and supply voltages could lead to unrecoverable damage of the system. The system could be destroyed. For the supply of the modules, power supply units in accordance with PELV or SELV specifications must be used. The creepage distances and clearances meet the requirements of the overvoltage category II, pollution degree 2.

#### Assembly position

Horizontal	•
Vertical	• (1)

(1) not in salt mist environment

#### Temperature

Operating	-40 °C ... +70 °C	
	-40 °C ... -30 °C	Proper start-up of system; technical data not guaranteed
	-40 °C ... 0 °C	Due to the LCD technology, the display might not be readable
	-40 °C...+40 °C	vertical mounting of modules possible, output load limited to 50 % per group
	+60 °C ...+70 °C	with the following deratings: System is limited to max. 2 Communication Modules per Terminal Base Applications certified for cULus up to 60 °C Digital inputs: maximum number of simultaneously switched on input channels limited to 75 % per group (e.g. 8 channels => 6 channels) Digital outputs: output current maximum value (all channels together) limited to 75 % per group (e.g. 8 A => 6 A) Analog outputs only if configured as voltage output: maximum total output current per group is limited to 75 % (e.g. 40 mA => 30 mA) Analog outputs only if configured as current output: maximum number of simultaneously used output channels limited to 75 % per group (e.g. 4 channels => 3 channels)
	Storage / Transport	-40 °C ... +85 °C

#### Humidity

Operating / Storage	100 % r. H. with condensation
---------------------	-------------------------------

#### Air pressure

Operating	-1000 m .... 4000 m (1080 hPa ... 620 hPa)
-----------	--

Storage	>2000 m (<795 hPa): max. operating temperature must be reduced by 10K per 1000 m (e.g. 70 °C to 60 °C)
---------	--

#### Immunity to corrosive gases

Operating	Yes, in accordance with: ANSI/ISA-71.04: Containment group A, G3 - Harsh / GX - Severe IEC 60068-2-60: Method 4 IEC 60721-3-3: Class 3C2 / 3C3  Gases and concentrations: Hydrogen sulfide (H <sub>2</sub> S): (100 ± 5) ppb Nitrogen dioxide (NO <sub>2</sub> ): (1250 ± 20) ppb Chlorine (Cl <sub>2</sub> ): (100 ± 5) ppb Sulfur dioxide (SO <sub>2</sub> ): (300 ± 20) ppb
-----------	--

#### Immunity to salt mist

Operating	Yes, horizontal mounting only, in accordance with IEC 60068-2-52 severity level: 1 NOTICE! Risk of corrosion! Unused connectors and slots may corrode, if using XC devices in salt mist environments. Protect unused connectors and slots with TA535 protective caps for XC devices.
-----------	--

# AC500-XC

## System data

### Environmental Conditions

#### Electromagnetic Compatibility

Radiated emission (radio disturbances)	Yes, in accordance with CISPR 16-2-3
Conducted emission (radio disturbances)	Yes, in accordance with CISPR 16-2-1, CISPR 16-1-2
Electrostatic discharge (ESD)	Yes, in accordance with IEC 61000-4-2, zone B, criterion B Electrostatic voltage in case of air discharge: 8 kV Electrostatic voltage in case of contact discharge: 6 kV
Fast transient interference voltages (burst)	Yes, in accordance with IEC 61000-4-4, zone B, criterion B Supply voltage units (DC): 4 kV Digital inputs/outputs (24 V DC): 2 kV Analog inputs/outputs: 2 kV Communication lines shielded: 2 kV I/O supply (DC-out): 2 kV
High energy transient interference voltages (surge)	Yes, in accordance with IEC 61000-4-5, zone B, criterion B Supply voltage units (DC): 1 kV CM* / 0.5 kV DM* Supply voltage units (AC): 2 kV CM* / 1 kV DM* Digital inputs/outputs (24 V DC): 1 kV CM* / 0.5 kV DM* Digital inputs/outputs (120...240 V AC): 2 kV CM* / 1 kV DM* Analog inputs/outputs: 1 kV CM* / 0.5 kV DM* Communication lines shielded: 1 kV CM* I/O supply (DC-out): 0,5 kV CM* / 0.5 kV DM* * CM = Common Mode, * DM = Differential Mode
Influence of radiated disturbances	Yes, in accordance with IEC 61000-4-3, zone B, criterion A Test field strength: 10 V/m
Influence of line-conducted interferences	Yes, in accordance with IEC 61000-4-6, zone B, criterion A Test voltage: 10 V
Influence of power frequency magnetic fields	Yes, in accordance with IEC 61000-4-8, zone B, criterion A 30 A/m 50 Hz 30 A/m 60 Hz

#### WARNING!

##### Risk of malfunctions and damages to persons!

Unused slots for communication modules are not protected against contact discharge. Dust and dirt may cause contact problems and malfunctions.

Unused slots for communication modules must be covered with dummy communication modules ("TA524 - Dummy Communication Module").

I/O-bus connectors must not be touched during operation.

In order to prevent malfunctions, it is recommended that the operating personnel discharge themselves prior to touching communication connectors or perform other suitable measures to reduce effects of electrostatic discharges.

#### Environmental Tests

<b>Storage</b>	IEC 60068-2-1 Test Ab: cold withstand test -40 °C / 16 h
	IEC 60068-2-2 Test Bb: dry heat withstand test +85 °C / 16 h
<b>Humidity</b>	IEC 60068-2-30 Test Db: Cyclic (12 h / 12 h) Damp-Heat Test 55 °C, 93 % r. H. / 25 °C, 95 % r. H., 6 cycles
	IEC 60068-2-78, Stationary Vibration Test: 40 °C, 93 % r. H., 240 h
<b>Shock resistance</b>	IEC 61131-2 / IEC 60068-2-6: 5 Hz ... 500 Hz, 2 g (with Memory Card inserted)
	IEC 60068-2-64: 5 Hz ... 500 Hz, 4 g rms
	IEC 60068-2-27: all 3 axes 15 g, 11 ms, half-sinusoidal

#### Mechanical Data

Wiring method	Spring terminals
Degree of protection	IP 20
Assembly on DIN rail	DIN rail type
	In accordance with IEC 60715 35 mm, depth 7.5 mm or 15 mm
Assembly with screws	Screw diameter
	4 mm
	Fastening torque
	1.2 Nm





---

# AC500-S

## Functional safety PLC

<b>199</b>	<b>Key features</b>
<b>200</b>	<b>Ordering data AC500-S</b>
<b>201</b>	<b>Ordering data AC500-S-XC</b>
<b>202–204</b>	<b>Technical data</b>
<b>205–208</b>	<b>System data</b>



SM560-S

ABB

WR   
DIAG   
RUN   
ERR   
ERR

SYS  
BATT  
I/O-Bus

run

ETH  
FBP  
COM  
COM

PWR



RUN



ERR



90  
2 3 4 5 6 7 8 9  
1 0 F E D C B A ADDR x10H  
1 2 3 4 5 6 7 8 9  
0 F E D C B A ADDR x01H

**WARNING**  
Use of incorrect battery may cause fire or explosion.

RUN  
DIAG  
VAL  
CFG  
ESC  
↑  
OK  
↓

MC 502

UP 24VDC 10W

# AC500-S

## Key features



Easy integration: Simple extension of ABB PLC with safety functions. One common engineering and diagnostic system for safety and standard CPUs. eXtreme Conditions (-XC) version is available.

Easy implementation of flexible configuration concept (one safety program for various machine types). Safety CPU can be configured to work even if standard CPU is in STOP mode.

ABB Ability™ Automation Builder productivity suite providing integrated support of ST, Ladder (LD) and Function Block Diagram (FBD) programming with a common look and feel. Trigonometric functions are supported for easy implementation of complex calculation tasks.

Both simple and complex safety functions can be easily implemented:

- Safely limited acceleration
- Safely limited deceleration
- Safely limited force
- Safely limited orientation
- Safely limited position
- Safely limited speed
- Safely limited torque.

PROFINET/PROFIsafe interface for decentralized safety I/Os, safe position and speed monitoring as well as triggering of safety drive functions. Configurable real-time exchange of high volume process and safety data between multiple PLC controllers using PROFINET/PROFIsafe.



## AC500-S

### Ordering data

#### Safety CPU

Description	User program memory		Type	Order code	Price	Weight (1 pce) kg
	MB					
Safety CPU module	1		SM560-S	1SAP280000R0001		0.100
Safety CPU module with F-Device functionality for 1 PROFI-safe network	1.3		SM560-S-FD-1	1SAP286000R0001		0.100
Safety CPU module with F-Device functionality for 4 PROFI-safe networks	1.3		SM560-S-FD-4	1SAP286100R0001		0.100

#### S500 Safety I/O

Description	Input signal		Output signal SIL3	Type	Order code	Price	Weight (1 pce) kg
	SIL2	SIL3					
Safety digital input module	16	8	-	DI581-S	1SAP284000R0001		0.130
Safety digital input / output module	8	4	8	DX581-S	1SAP284100R0001		0.130
Safety analog input module	4	2	-	AI581-S	1SAP282000R0001		0.130

#### S500 Safety terminal unit

Description	Type	Order code	Price	Weight (1 pce) kg
Spring terminal unit for safety I/O modules	TU582-S	1SAP281200R0001		0.200

#### Software

AC500-S safety PLC programming license needs to be purchased as an additional feature of ABB Ability™ Automation Builder. For details, see ordering data of Automation Builder.



SM560-S  
SM560-S-FD-1  
SM560-S-FD-4



DI581-S  
DX581-S  
AI581-S



TU582-S

#### Accessories for AC500-S

For	Description	Type	Order code	Price	Weight (1 pce) kg
AC500-S safety PLC training case	SM560-S, DI581-S, DX581-S, AI581-S, TU582-S with PM573-ETH and PNIO	TA514-SAFETY	1SAP182900R0001		10



AC500-S training case

## AC500-S-XC

### Ordering data

#### Safety XC CPU

Description	User program memory		Type	Order code	Price	Weight (1 pce) kg
	MB					
Safety CPU module	1		SM560-S-XC	1SAP380000R0001		0.100
Safety CPU module with F-Device functionality for 1 PROFI-safe network	1.3		SM560-S-FD-1-XC	1SAP386000R0001		0.100
Safety CPU module with F-Device functionality for 4 PROFI-safe networks	1.3		SM560-S-FD-4-XC	1SAP386100R0001		0.100

#### S500-XC Safety I/O

Description	Input signal		Output signal SIL3	Type	Order code	Price	Weight (1 pce) kg
	SIL2	SIL3					
Safety digital input module	16	8	-	DI581-S-XC	1SAP484000R0001		0.130
Safety digital input / output module	8	4	8	DX581-S-XC	1SAP484100R0001		0.130
Safety analog input module	4	2	-	AI581-S-XC	1SAP482000R0001		0.130

#### S500-XC Safety terminal unit

Description	Type	Order code	Price	Weight (1 pce) kg
Spring terminal unit for safety I/O modules	TU582-S-XC	1SAP481200R0001		0.200



SM560-S-XC  
SM560-S-FD-1-XC  
SM560-S-FD-4-XC



DI581-S-XC  
DX581-S-XC  
AI581-S-XC



TU582-S-XC

## AC500-S and AC500-S-XC

### Technical data

#### Safety CPUs

Type		SM560-S / SM560-S-XC	SM560-S-FD-1 / SM560-S-FD-4 / SM560-S-FD-1-XC / SM560-S-FD-4-XC
Performance level		PL e (ISO 13849-1)	
Safety	integrity level	SIL3 (IEC 61508:2010, IEC 62061, IEC 61511)	
	protocol	PROFIsafe V2 F-Host via PROFINET	PROFIsafe V2 F-Host and F-Device (for 1 or 4 PROFIsafe networks, respectively) via PROFINET
Program memory flash EPROM and RAM		1 MB	1.3 MB
Integrated data memory		1 MB thereof 120 kB saved	1.0 MB thereof 120 kB saved
<b>Cycle time for 1 instruction</b>			
Binary		0.05 µs	
Word		0.06 µs	
Floating point		0.5 µs	
<b>Max. number of centralized inputs/outputs</b>			
Max. nb. of safety extension modules on I/O bus		10	
Digital	inputs	160 (SIL2) / 80 (SIL3)	
	outputs	80 (SIL3)	
Analog	inputs	40 (SIL2) / 20 (SIL3)	
Max. number of decentralized inputs/outputs		On PROFINET: up to 128 stations with up to 10 safety extension modules	
<b>Program execution</b>			
Cyclical		•	
User program protection by password		•	
<b>Interfaces</b>			
Ethernet		Via AC500 CPU or PROFINET coupler	
COM		Via AC500 CPU	
Programming		Via AC500 CPU	
Approvals		CE, cUL, UL, C-Tick and other on request	

## AC500-S and AC500-S-XC

### Technical data

#### S500 and S500-XC Safety I/O

Type	DI581-S / DI581-S-XC	DX581-S / DX581-S-XC	AI581-S / AI581-S-XC
Performance Level	PL e (ISO 13849-1)		
Safety Integrity Level	SIL3 (IEC 61508:2010, IEC 62061, IEC 61511)		
Safety protocol	PROFIsafe V2 via PROFINET		
<b>Digital inputs</b>			
Number of channels per module	16 (SIL2) / 8 (SIL3)	8 (SIL2) / 4 (SIL3)	-
Input signal voltage	24 V DC	24 V DC	-
Frequency range	65 Hz	65 Hz	-
Input characteristic acc. to EN61131-2	Type 1	Type 1	-
0 signal	-3...+5 V DC	-3...+5 V DC	-
Undefined signal state	5...15 V DC	5...15 V DC	-
1 signal	15...30 V DC	15...30 V DC	-
Input time delay (0 -> 1 or 1 -> 0)	Input filter configurable from 1, 2, 5...500 ms	Input filter configurable from 1, 2, 5...500 ms	-
Test pulse outputs	8	4	-
<b>Input current per channel</b>			
At input voltage	24 V DC / 7 mA typically	24 V DC / 7 mA typically	-
	5 V DC / < 1 mA	5 V DC / < 1 mA	-
	15 V DC / > 4 mA	15 V DC / > 4 mA	-
	30 V DC / < 8 mA	30 V DC / < 8 mA	-
<b>Digital outputs</b>			
Number of channels per module	-	8 (SIL3)	-
Transistor outputs 24 V DC, 0.5 A	-	●	-
Transistor outputs 24 V DC, 2 A	-	● (1)	-
Switching of 24 V load	-	●	-
Safety relay outputs	-	● (2)	-
<b>Output current</b>			
Nominal current per channel	-	500 mA at UP = 24 V	-
Maximum (total current of all channels)	-	4 A / 500 mA / channel	-
Residual current at signal state 0	-	< 0.5 mA	-
Demagnetization when switching off inductive loads	-	By internal suppressor diodes	-
<b>Switching frequency</b>			
Short-circuit / overload proofness	-	●	-
For inductive load	-	On request	-
For lamp load	-	On request	-
Proofness against reverse feeding of 24 V signals	-	●	-

(1) Transistor outputs 24 V DC, 2 A. For details, please see application notes in chapter 8.

(2) Safety relay outputs using external safety relay, e.g. ABB BSR23. For details, please see application notes in chapter 8.

## AC500-S and AC500-S-XC

### Technical data

#### S500 and S500-XC Safety I/O

Type	DI581-S / DI581-S-XC	DX581-S / DX581-S-XC	AI581-S / AI581-S-XC
<b>Analog inputs</b>			
Number of channels per module	-	-	4 (SIL2) / 2 (SIL3)
Input resistance per channel	-	-	125 Ohm
Time constant of the input filter	-	-	10 ms
Conversion cycle	-	-	0.33 ms
Overvoltage protection	-	-	-
<b>Signal resolution for channel configuration</b>			
0...20 mA, 4...20 mA	-	-	14 bits
<b>Process voltage UP</b>			
Nominal voltage	24 V DC		
Maximum ripple	5 %		
Reverse polarity protection	●		
Fuse for process voltage UP	10 A miniature fuse		
Connections for sensor voltage supply Terminal 24 V and 0 V	●		
Conversion error of analog values caused by non-linearity, calibration errors ex and the resolution in the nominal range	-	-	±1.5 %
<b>Maximum cable length for connected process signals</b>			
Shielded cable	1000 m	1000 m	-
Unshielded cable	600 m	600 m	-
Max. line length of the analog lines, conductor cross section > 0.14 mm <sup>2</sup>	-	-	100 m
<b>Potential isolation</b>			
Per module	●		
Fieldbus connection	Via AC500 CPU or PROFINET communication module		
Voltage supply for the module	Internally via extension bus interface (I/O bus)		
<b>Approvals</b>	CE, cUL, UL, C-Tick and other on request		

## AC500-S

### System data

#### Operating and ambient conditions

##### Voltages according to EN 61131-2

24 V DC	Process and supply voltage	24 V (-15 %, +20 %)
	Protection against reverse polarity	Yes
Allowed interruptions of power supply acc. to EN 61131-2	DC supply	Interruption < 10 ms, time between 2 interruptions > 1 s

**Important:** Exceeding the maximum process and supply voltages could lead to unrecoverable damage of the system. The system could be destroyed.

##### Temperature

Operating	0 °C ... +60 °C	horizontal mounting of modules
	0 °C ... +40 °C	vertical mounting of modules and output load reduced to 50 % per group
Storage / Transport	-40 °C ... +70 °C	

##### Humidity

Operating / Storage	Max. 95 %, without condensation
---------------------	---------------------------------

##### Air pressure

Operating	> 800 hPa / < 2000 m
Storage	> 660 hPa / < 3500 m

#### Creepage distances and clearances

<b>Insulation Test Voltages, Routine Test, according to EN 61131-2</b>	<b>AC voltage during 2 seconds</b>
24 V circuits (supply, 24 V inputs/outputs), if they are electrically isolated against other circuitry	350 V

The creepage distances and clearances meet the requirements of the overvoltage category II, pollution degree 2.

## AC500-S

### System data

#### Power supply units

For the supply of the modules, power supply units according to PELV specifications must be used.

#### Electromagnetic Compatibility

Immunity		
Against electrostatic discharge (ESD)		
Electrostatic voltage in case of	air discharge	±8 kV
	contact discharge	±6 kV
ESD with communication connectors		
In order to prevent operating malfunctions, it is recommended that the operating personnel discharge themselves prior to touching communication connectors or perform other suitable measures to reduce effects of electrostatic discharges.		
ESD with connectors of Terminal Bases		
The connectors between the Terminal Bases and CPUs or Communication Modules must not be touched during operation. The same is valid for the I/O-Bus with all modules involved.		
Against the influence of radiated (CW radiated)		
Test field strength		10 V/m
Against transient interference voltages (burst)		
Supply voltage units	DC	2 kV
Digital inputs/outputs	24 V DC	2 kV
Analog inputs		1 kV
Against the influence of line-conducted interferences (CW conducted)		
Test voltage		10 V zone B
High energy surges		
Power supply	DC	1 kV CM (1) / 0.5 kV DM (2)
DC I/O supply, add. DC-supply-out		0.5 kV CM (2) / 0.5 kV DM (2)
I/O analog, I/O DC unshielded		1 kV CM (2) / 0.5 kV DM (2)
Radiation (radio disturbance)		
In accordance with EN 55011, group 1, class A		

(1) High requirement for shipping classes is achieved with additional specific measures (see specific documentation).

(2) CM = Common Mode; DM = Differential Mode.

#### Mechanical Data

Wiring method / terminals	
Mounting	Horizontal (DIN rail mounting)
Degree of protection	IP20
Housing	In accordance with UL 94
Vibration resistance acc. to EN 61131-2	all three axes (DIN rail mounting) 5...11.9 Hz, continuous 3.5 mm 11.9...150 Hz, continuous 1 g
Shock resistance	All three axes 15 g, 11 ms, half-sinusoidal
Mounting of the modules	
DIN rail according to DIN EN 50022	35 mm, depth 7.5 mm or 15 mm
Mounting with screws	Screws with a diameter of 4 mm
Fastening torque	1.2 Nm



## AC500-S-XC

### System data

#### Operating and ambient conditions

##### Voltages according to EN 61131-2

24 V DC	Process and supply voltage	24 V (-15 %, +20 %)
	Protection against reverse polarity	Yes
Allowed interruptions of power supply acc. to EN 61131-2	DC supply	Interruption < 10 ms, time between 2 interruptions > 1 s

**Important:** Exceeding the maximum process and supply voltages could lead to unrecoverable damage of the system. The system could be destroyed.

##### Temperature

Operating	-40 °C ... +70 °C	horizontal mounting of modules
	-40 °C ... +40 °C	vertical mounting of modules and output load reduced to 50 % per group
Storage / Transport	-40 °C ... +85 °C	

##### Humidity

Operating / Storage	Max. 100 %, with condensation
---------------------	-------------------------------

##### Air pressure

Operating	620...1080 hPa / (-1000...4000 m) > 2000 m (< 795 hPa): max. operating temperature must be reduced by 10 °C.
Storage	> 620 hPa / < 4000 m

#### Creepage distances and clearances

Insulation Test Voltages, Routine Test, according to EN 61131-2	AC voltage during 2 seconds
24 V circuits (supply, 24 V inputs/outputs), if they are electrically isolated against other circuitry	350 V

The creepage distances and clearances meet the requirements of the overvoltage category II, pollution degree 2.

## AC500-S-XC

### System data

#### Power supply units

For the supply of the modules, power supply units according to PELV specifications must be used.

#### Electromagnetic Compatibility

Immunity		
Against electrostatic discharge (ESD)		
Electrostatic voltage in case of	air discharge	±8 kV
	contact discharge	±6 kV
ESD with communication connectors		
In order to prevent operating malfunctions, it is recommended that the operating personnel discharge themselves prior to touching communication connectors or perform other suitable measures to reduce effects of electrostatic discharges.		
ESD with connectors of Terminal Bases		
The connectors between the Terminal Bases and CPUs or Communication Modules must not be touched during operation. The same is valid for the I/O-Bus with all modules involved.		
Against the influence of radiated (CW radiated)		
Test field strength		10 V/m
Against transient interference voltages (burst)		
Supply voltage units	DC	2 kV
Digital inputs/outputs	24 V DC	2 kV
Analog inputs		1 kV
Against the influence of line-conducted interferences (CW conducted)		
Test voltage		10 V zone B
High energy surges		
Power supply	DC	1 kV CM (1) / 0.5 kV DM (2)
DC I/O supply, add. DC-supply-out		0.5 kV CM (2) / 0.5 kV DM (2)
I/O analog, I/O DC unshielded		1 kV CM (2) / 0.5 kV DM (2)
Radiation (radio disturbance)		
In accordance with EN 55011, group 1, class A		

(1) High requirement for shipping classes is achieved with additional specific measures (see specific documentation).

(2) CM = Common Mode; DM = Differential Mode.

#### Mechanical Data

Wiring method / terminals	
Mounting	Horizontal (DIN rail mounting)
Degree of protection	IP20
Housing	In accordance with UL 94
Vibration resistance acc. to EN 61131-2	all three axes (DIN rail mounting) 5...11.9 Hz, continuous 3.5 mm 11.9...150 Hz, continuous 1 g
Shock resistance	All three axes 15 g, 11 ms, half-sinusoidal
Mounting of the modules	
DIN rail according to DIN EN 50022	35 mm, depth 7.5 mm or 15 mm
Mounting with screws	Screws with a diameter of 4 mm
Fastening torque	1.2 Nm





---

# CP600-eCo, CP600 and CP600-Pro

## Control panels

<b>213</b>	<b>Key features</b>
<b>214–216</b>	<b>Ordering data</b>
<b>217–219</b>	<b>Technical data</b>



← → 15:38:22  
10 Jul 2021

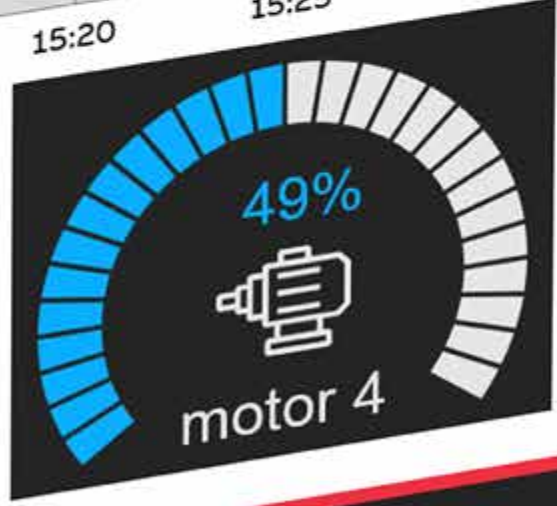
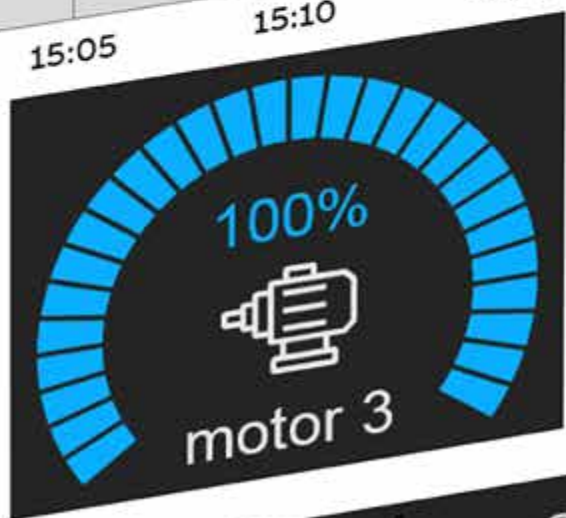
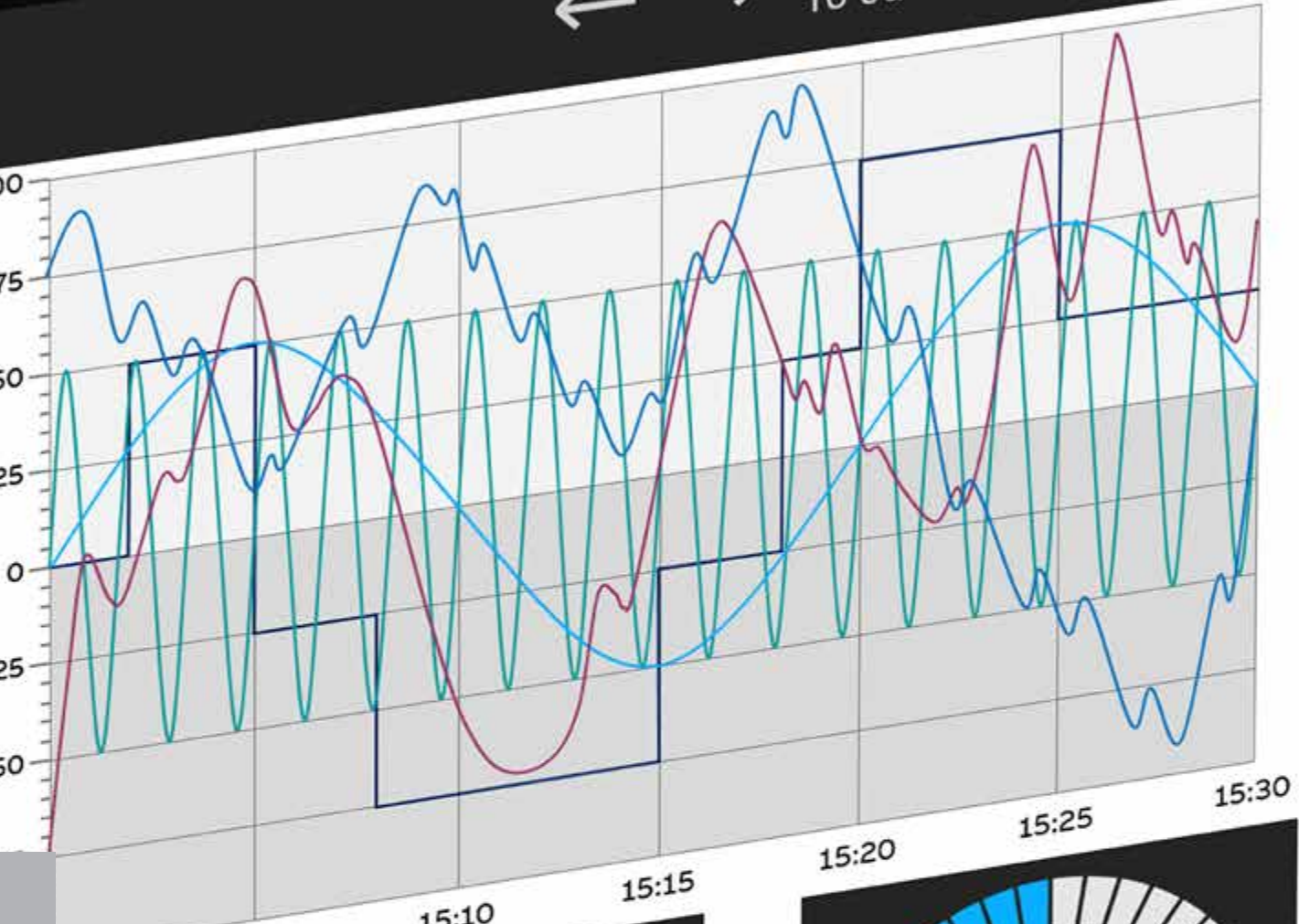

HVAC

Chiller

Alarm

e 2

# CP600-eCo, CP600 and CP600-Pro

## Key features

Various options for tailor made HMI solutions:

- PB610 Panel Builder 600 HMI applications
- Visualization of AC500 web servers (V3)
- Mobile remote access to HMI applications
- PB610-R PC runtime for Windows platforms
- Drivers for integration into automation systems
- OPC UA client and server



### CP600

- Brilliant display
- Aluminium enclosure
- Operating temperature: -20...+60 °C
- Three different screen sizes
- Usable as web panel

### CP600-Pro

- Multi-touch
- Brilliant real glass screen
- Aluminium enclosure
- Fast ETH 10/100/1000
- Operating temperature: -20...+60 °C
- Five different screen sizes from 5" to 21.5"
- Usable as web panel

### CP600-eCo

- Slim design for easy installation even in compact spaces
- Robust plastic enclosure
- Three different screen sizes
- CP610 usable as web panel



## CP600-eCo, CP600 and CP600-Pro

### Ordering data

#### CP600-eCo control panels

Display size	Resolution pixels	Description	Type	Order code	Price	Weight (1 pce) kg
4.3"	480 x 272	for PB610 applications	CP604	1SAP504100R0001		0.400
7.0"	800 x 480	for PB610 applications	CP607	1SAP507100R0001		0.600
10.1"	1024 x 600	for PB610 applications or visualization of AC500 V3 web server	CP610	1SAP510100R0001		1.000
4.3"	480 x 272	black, for PB610 applications	CP604-B	1SAP504100R2001		0.400
7.0"	800 x 480	black, for PB610 applications	CP607-B	1SAP507100R2001		0.600
10.1"	1024 x 600	black, for PB610 applications or visualization of AC500 V3 web server	CP610-B	1SAP510100R2001		1.000

Visualization of AC500 V3 web server is supported by products with revision index C1 or higher.



CP604

CP607

CP610

CP607-B

#### CP600 control panels

Display size	Resolution pixels	Description	Type	Order code	Price	Weight (1 pce) kg
7"	800 x 480	for PB610 applications or visualization of AC500 V3 web server	CP6407	1SAP540710R0001		1.000
10.4"	800 x 600	for PB610 applications or visualization of AC500 V3 web server	CP6410	1SAP541010R0001		2.000
15"	1024 x 768	for PB610 applications or visualization of AC500 V3 web server	CP6415	1SAP541510R0001		3.300

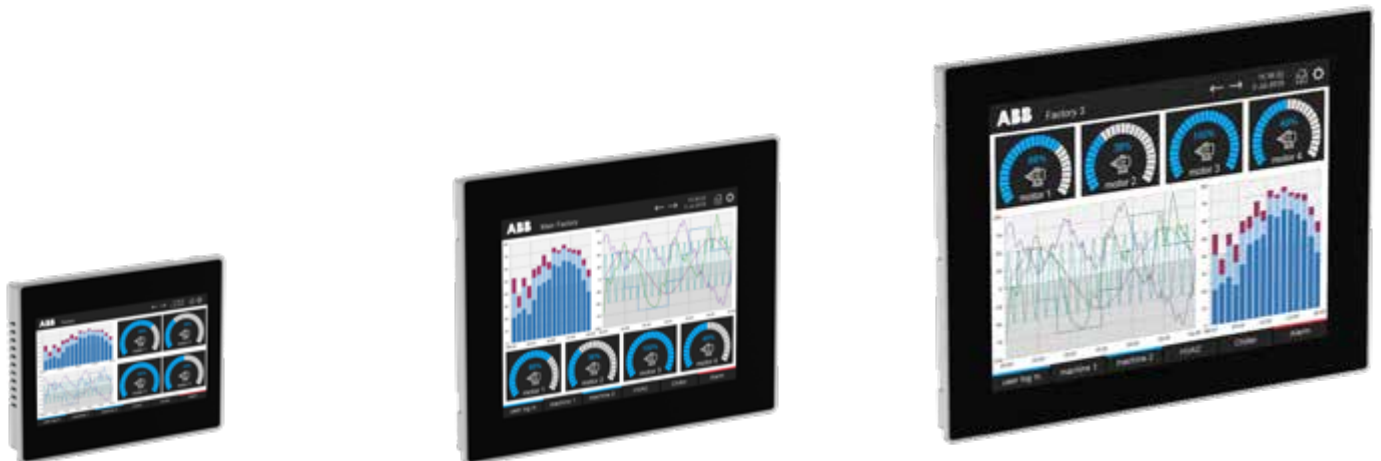

CP6407

CP6410

CP6415

## CP600-eCo, CP600 and CP600-Pro

### Ordering data

#### CP600-Pro control panels

Display size	Resolution pixels	Description	Type	Order code	Price	Weight (1 pce) kg
5.0"	800 x 480	for PB610 applications or visualization of AC500 V3 web server	CP6605	1SAP560510R0001		1.000
7.0"	800 x 480	for PB610 applications or visualization of AC500 V3 web server (1)	CP6607	1SAP560710R0001		1.300
10.1"	1280 x 800	for PB610 applications or visualization of AC500 V3 web server (1)	CP6610	1SAP561010R0001		1.700
15.6"	1366 x 768	for PB610 applications or visualization of AC500 V3 web server (1)	CP6615	1SAP561510R0001		4.100
21.5"	1920 x 1080	for PB610 applications or visualization of AC500 V3 web server	CP6621	1SAP562110R0001		6.100

(1) Can be used to trigger safety actions in combination with AC500-S.



CP6605



CP6610



CP6621

## CP600-eCo, CP600 and CP600-Pro

### Ordering data

#### Communication cables (connection control panel <-> PLC)

Description	Type	Order code	Price	Weight (1 pce) kg
Communication cable RS232: CP600-eCo, CP600, CP600-Pro <-> AC500	TK681	1SAP500981R0001		0.130
Communication cable RS485: CP600-eCo, CP600, CP600-Pro <-> AC500-eCo	TK682	1SAP500982R0001		0.130

#### Programming software licenses

Description	Type	Order code	Price	Weight (1 pce) kg
PB610 Panel Builder 600, engineering tool license for CP600-eCo, CP600, CP600-Pro control panels and PB610-R PC-runtime, for stand-alone installation via Automation Builder installer. PB610 is included in Automation Builder Standard.	PB610	1SAP500900R0101		0.005
PB610-R Panel Builder 600 runtime license for running a PB610 application on one Windows 32-/64-Bit platform. Installation via Automation Builder installer.	PB610-R	1SAP500901R0101		0.005



#### CP600 platform selection guide for tailor made HMI applications

CP600-eCo	for PB610 HMI applications; CP610: Or visualization of AC500 V3 web server (*)
CP600	for PB610 HMI applications or visualization of AC500 V3 web server
CP600-Pro	for PB610 HMI applications or visualization of AC500 V3 web server

(\*) Supported by products with revision index C1 or higher

## CP600-eCo series

### Technical data

Type	CP604 CP604-B	CP607 CP607-B	CP610 CP610-B
Application	control panels for PB610 Panel Builder 600 applications		visualization of AC500 V3 web server (*)
<b>Display</b>			
Exact display size diameter	4.3" widescreen	7" widescreen	10.1" widescreen
Resolution	480 x 272 pixels	800 x 480 pixels	1024 x 600 pixels
Display type, colors	TFT-LCD, 65536 colors		
Touch screen material	glass covered by plastic film		
Touch screen type	single-touch, analog resistive, 4 wires		
Backlight type, life	LED, 20 000 h typ at 25 °C		
Brightness	150 cd/m <sup>2</sup>	200 cd/m <sup>2</sup>	
<b>System resources</b>			
Processor type	ARM Cortex-A8; 300 MHz	ARM Cortex-A8; 300 MHz	ARM Cortex-A8; 1 GHz
Operating system, version	Linux RT		
Application memory	for HMI projects of 30 MB in total plus 30 MB for fonts		
<b>Interfaces</b>			
Ethernet ports, number, type	1 - 10/100 Mbit		
USB Host ports number, type	1 - ver. 2.0		
Serial ports number, type	1 - RS-232/-485/-422 software configurable		
Card slot number, type	none		
<b>Power supply</b>			
Power supply voltage nominal, tolerance	24 V DC, 18...32 V DC		
Current consumption at nominal voltage	0.25 A	0.3 A	0.4 A
Backup power type	Supercapacitor, 72 h at 25 °C		
<b>Enclosure</b>			
Degree of protection front, rear	IP66, IP20		
Front frame material	Plastic		
Reverse side material	Plastic		
Weight	0.4 kg	0.6 kg	1.0 kg
Faceplate dimensions (L x H)	147 mm x 107 mm	187 mm x 147 mm	282 mm x 197 mm
Faceplate depth	5 mm		6 mm
Enclosure depth	29 mm		
Cutout dimensions (L x H)	136 mm x 96 mm	176 mm x 136 mm	271 mm x 186 mm
<b>Environmental conditions</b>			
Operating temperature range	0...50 °C		
Operating humidity range	5...85 % relative humidity, non-condensing		
Storage temperature range	-20...+70 °C		
Storage humidity range	5...85 % relative humidity, non-condensing		
<b>Approvals</b>	See detailed page 272 or <a href="http://www.abb.com/plc">www.abb.com/plc</a>		

(\*) Supported by products with revision index C1 or higher

## CP600 series

### Technical data

Type	CP6407	CP6410	CP6415
Application	control panels for PB610 Panel Builder 600 applications or visualization of AC500 V3 web server		
<b>Display</b>			
Exact display size diameter	7" widescreen	10.4"	15"
Resolution	800 x 480 pixels	800 x 600 pixels	1024 x 768 pixels
Display type, colors	TFT-LCD, 65536 colors		
Touch screen material	glass covered by plastic film		
Touch screen type	single-touch, analog resistive, 4 wires		
Backlight type, life	LED, 40 000 h typ at 25 °C		
Brightness	400 cd/m <sup>2</sup>		
<b>System resources</b>			
Processor type	ARM Cortex-A8; 1 GHz		
Operating system, version	Linux RT		
Application memory	150 MB		
<b>Interfaces</b>			
Ethernet ports, number, type	2 - 10/100 Mbit (with integrated bridge function)		
USB Host ports number, type	2 - ver. 2.0		
Serial ports number, type	1 - RS-232/-485/-422 software configurable		
Card slot number, type	1 - Memory card slot		
<b>Power supply</b>			
Power supply voltage nominal, tolerance	24 V DC, 18...32 V DC		
Current consumption at nominal voltage	0.35 A	0.4 A	0.7 A
Backup power type, capacity	Rechargeable Lithium battery, not user-replaceable		
<b>Enclosure</b>			
Degree of protection front, rear	IP66, IP20		
Front frame material	aluminium		
Reverse side material	aluminium		
Weight	1 kg	2 kg	3.3 kg
Faceplate dimensions (L x H)	187 mm x 147 mm	287 mm x 232 mm	392 mm x 307 mm
Faceplate depth	4 mm		
Enclosure depth	40 mm	40 mm	45 mm
Cutout dimensions (L x H)	176 mm x 136 mm	276 mm x 221 mm	381 mm x 296 mm
<b>Environmental conditions</b>			
Operating temperature range	-20...+60 °C		
Operating humidity range	5...85 % relative humidity, non-condensing		
Storage temperature range	-20...+70 °C		
Storage humidity range	5... 85 % relative humidity, non-condensing		
<b>Approvals</b>	See detailed page 272 or <a href="http://www.abb.com/plc">www.abb.com/plc</a>		

## CP600-Pro series

### Technical data

Type	CP6605	CP6607	CP6610	CP6615	CP6621
Application	control panels for PB610 Panel Builder 600 applications or visualization of AC500 V3 web server				
<b>Display</b>					
Exact display size diameter	5" widescreen	7" widescreen	10.1" widescreen	15.6" widescreen	21.5" widescreen
Resolution	800 x 480 pixels	800 x 480 pixels	1280 x 800 pixels	1366 x 768 pixels	1920 x 1080 pixels
Display type, colors	TFT-LCD, 65536 colors		TFT-LCD, 16 Mio colors		
Touch screen material	true glass, black passepartou				
Touch screen type	multi-touch, 2-points gestures, PCAP, projected capacitive touchscreen				
Backlight type, life time	LED, 40 000 h typ at 25 °C				
Brightness	300 cd/m <sup>2</sup>	500 cd/m <sup>2</sup>	500 cd/m <sup>2</sup>	300 cd/m <sup>2</sup>	300 cd/m <sup>2</sup>
<b>System resources</b>					
Processor type	ARM Cortex-A8; 1 GHz	ARM Cortex-A9 dual core; 800 MHz	ARM Cortex-A9 dual core; 800 MHz	ARM Cortex-A9 quad core; 800 MHz	ARM Cortex-A9 quad core; 800 MHz
Operating system, version	Linux RT				
Application memory	for HMI projects of up to 240 MB in total				
<b>Interfaces</b>					
Ethernet ports, number, type	2 - 10/100 Mbit (with integrated bridge function)	2 - 10/100 Mbit (with integrated bridge function) 1 - 10/100/1000 Mbit			
USB Host ports, number, type	1 - ver. 2.0	2 - ver. 2.0			
Serial ports number, type	1 - RS-232/-485/-422 software configurable				
Card slot number, type	1 - Memory card slot				
<b>Power supply</b>					
Power supply voltage nominal, tolerance	24 V DC, 18...32 V DC				
Current consumption at nominal voltage	1.0 A	0.7 A	1.0 A	1.2 A	1.7 A
Backup power type, capacity	Rechargeable Lithium battery, not user-replaceable				
<b>Enclosure</b>					
Degree of protection front, rear	IP66, IP20				
Front frame material	aluminium, black				
Reverse side material	aluminium				
Weight	1.3 kg	1.3 kg	1.7 kg	4.1 kg	6.1 kg
Faceplate dimensions (L x H)	147 mm x 107 mm	187 mm x 147 mm	282 mm x 197 mm	422 mm x 267 mm	552 mm x 347 mm
Faceplate depth	8.5 mm	8.5 mm	8.5 mm	8.5 mm	8.5 mm
Enclosure depth	52 mm	47 mm	52 mm	56 mm	56 mm
Cutout dimensions (L x H)	136 mm x 96 mm	176 mm x 136 mm	271 mm x 186 mm	411 mm x 256 mm	541 mm x 336 mm
<b>Environmental conditions</b>					
Operating temperature range	-20...+60 °C				
Operating humidity range	5...85 % relative humidity, non-condensing				
Storage temperature range	-20...+70 °C				
Storage humidity range	5...85 % relative humidity, non-condensing				
Approvals	See detailed page 272 or <a href="http://www.abb.com/plc">www.abb.com/plc</a>				







# Application descriptions and additional information

222–223	AC500 digitalization for a more productive and sustainable future
224–225	AC500 as IoT gateway
226–227	IEC 61850 protocol for substation and switchboard automation with AC500
228–229	Future-proof building automation with AC500
230–231	Building automation with AC500, KNX and BACnet
232–233	Tunnel automation with AC500
234–235	AC500 HA offers hot standby redundancy
236–237	Hot Swap of S500 I/O modules for increased availability
238–239	S500 I/O modules run with various controllers
240–241	Integration of AC500 PLC into ABB Ability™ System 800xA
242–243	Condition Monitoring with AC500 PLC
244–245	Machine controllers based on AC500 PLC
246	Real-time Ethernet functionality
247	AC500 as advanced RTU controller
248–249	Safer, greener and more productive with AC500-S safety PLC
250–251	Embedding safety I/Os in ABB robots enhances man-machine collaboration
252–253	Safe communication between safety CPUs using PROFINET/PROFIsafe over 5G
254–255	Triggering safety actions using standard HMI
256	Cyber Security
257–261	PLC training and support
262–265	AC31 adapter for retrofitting existing AC31 applications, AC31 adapter for spare parts
266	Services
267	Life cycle management
268–270	ABB Ability™ Automation Builder product life cycle plan
271	Generic composition of type designation
272–278	Certifications

# Application descriptions

## AC500 digitalization for a more productive and sustainable future

How to bring your process data safely to your cloud

### Secure your site investment with AC500 V3

No matter whether you are managing one small machine or a large site, obtaining clear information is equally important.

No matter whether there are a few signals or 1000 signals, the AC500 can be adapted easily to exact requirements with secure cloud protocols already from basic PLCs or HMIs.

### AC500 V3 the perfect data collector

AC500 V3 can easily connect with many different control systems on site.

Since AC500 is not restricted to particular protocols it is easy to find the right protocol or I/O module to receive or send data.

The huge computing capacity of the CPUs allows connection to several hundred systems and sending and/or receiving data via secure protocols such as OPC UA, MQTT to/from any open cloud application.

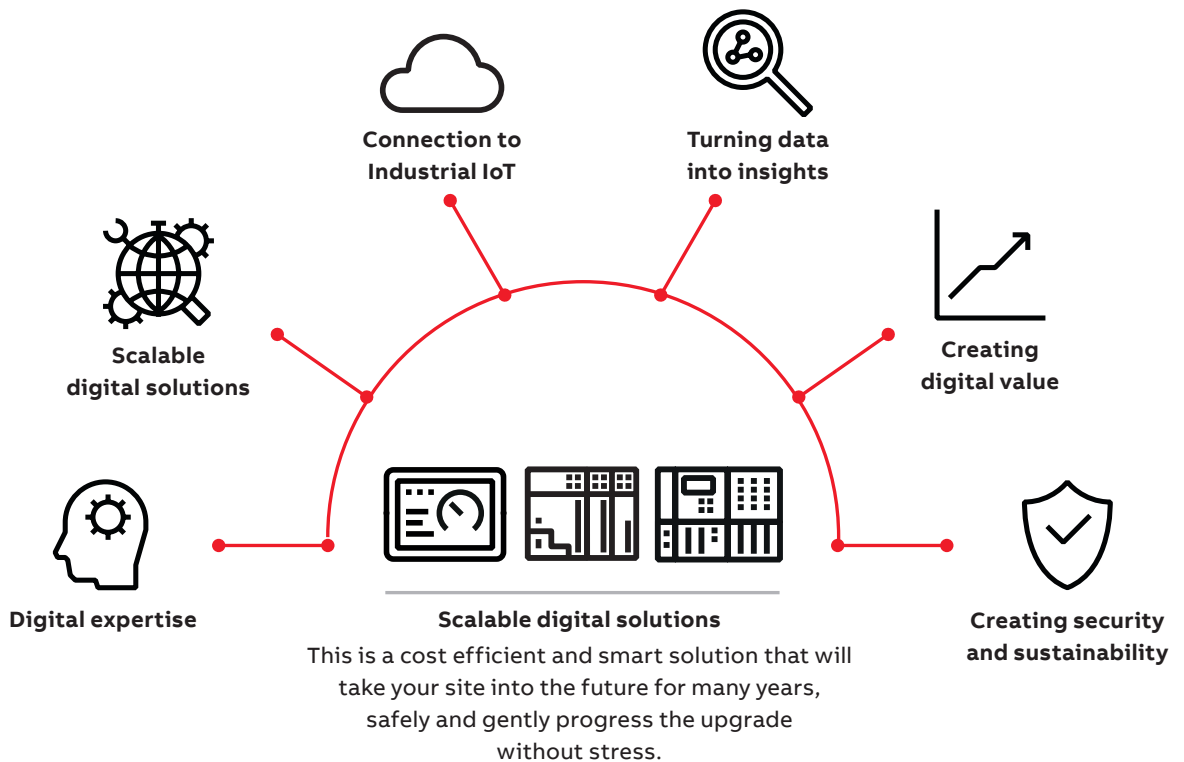

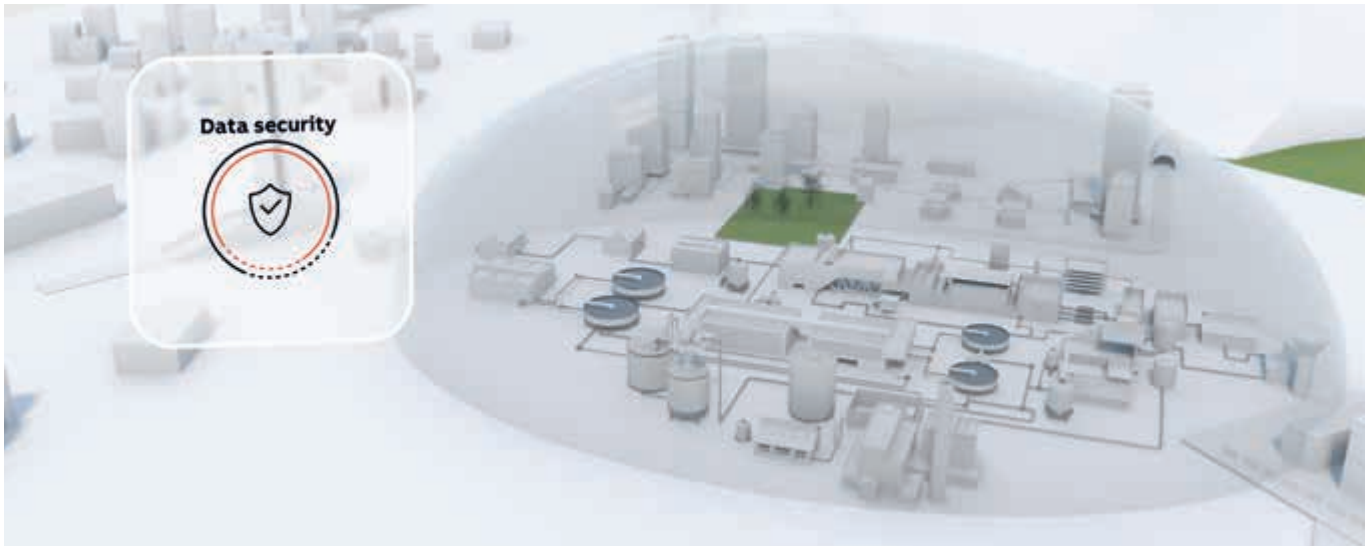

#### Digital expertise

ABB Ability™ brings together all of ABB's digital expertise to create real business value for customers.



#### Turning data into insights

Make raw data available for evaluation, present findings in a strategic way and take actions.



#### Scalable digital solutions

From easy connectivity to integrated and optimized services and expertise all the way through to customer support, system analysis, automation and optimization.



#### Creating digital value

Collect information, make decisions and set priorities on the basis of these findings.



#### Connection to Industrial IoT

Connectivity and software innovation enable real-time, data-driven decisions for safer, smarter and more sustainable industrial operations.



#### Creating security and sustainability

Certified for "Secure product development lifecycle requirement" as well as secure connections to encrypt data from being exposed.

# Application descriptions

## AC500 as IoT gateway

Cost efficient and extendable solution

- Scalable & platform-independent cloud connectivity
- Adaptable functionality through interchangeable modules
- Smart data handling on edge-level for cost-efficient cloud-solutions

Connection of single controller

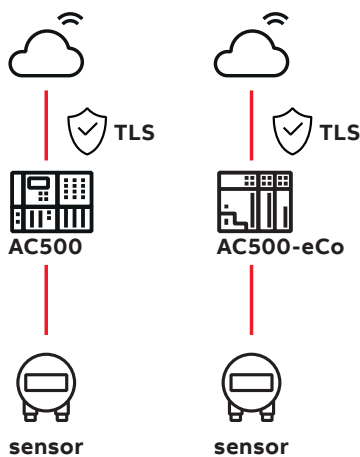

### Security level: optimized for remote units

AC500 works as edge-gateway and is directly connected to the cloud. Security is established through TLS encryption.

### Benefits:

- No additional gateway required
- Low latency

### Application:

Small systems with non-critical data transfer.

Connection of secured network

### Security level: advanced

Connection of the whole AC500 network to the cloud using a separate gateway. Enhanced security is provided through additional firewall and/or VPN.

### Benefits:

- Advanced level of security
- Easy integration of many edge devices

### Application:

Large systems with many devices which need higher protection.

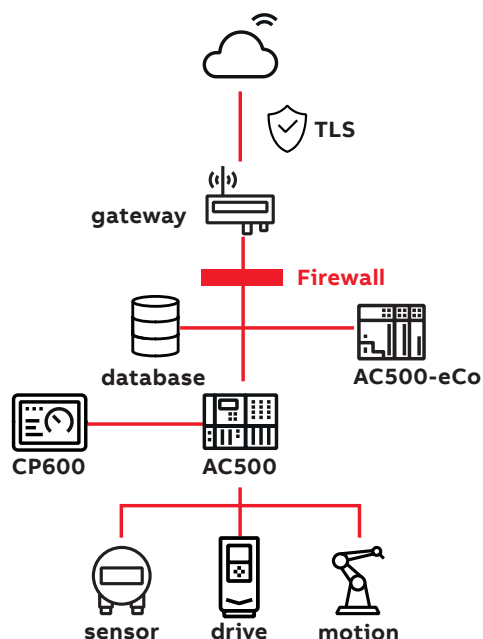

## IoT gateway

### Application

Small applications with simple I/Os and direct data transfer (e.g. energy monitoring of radio towers)

### Benefits

- Cost-efficient
- Resource-friendly
- Low implementation effort



TELECOMMUNICATION

## IoT Controller Advanced

### Application

Applications with functional safety requirements which need additional functionality (e.g. functional safety control for cranes)

### Benefits

- Ensured safety for machines and staff



CRANES

## IoT data center

### Application

Critical assets that need permanent protection & monitoring (e.g. vibration monitoring for pumps)

### Benefits

- Permanent asset protection
- Increased resilience to internet outages
- Cost efficient monitoring



WATER

## IoT controller

### Application

Demanding applications with a larger system architecture and complex data handling (e.g. remote data logging for drives/winch control)

### Benefits

- Easy cloud connection of whole system
- Active control of transferred data
- Advanced control functionalities



MARINE

# Application descriptions

## IEC 61850 protocol for substation and switchboard automation with AC500

AC500 as freely programmable 61850 controller, gateway or IED

### **AC500 is used as Intelligent Electronic Device (IED), RTU or controller**

IEC 61850 is a standard protocol for state-of-the-art, future-proof substation automation, which replaces hard wiring of signals by communication over the network. The AC500 V3 can be programmed to act as an Intelligent Electronic Device (IED), RTU or used in control applications such as e.g. load shedding.

### **Interoperability between devices made easy**

Generic Object-Oriented Substation Event (GOOSE) messages are used for the interoperability of devices with minimal delay, e.g. for fast tripping or interlocking or monitoring applications. With the IEC 61850 library and the comfortable communication the AC500 PLC can be used for the publishing of and subscribing to GOOSE messages. The IEC 61850 protocol of the AC500 PLC is TÜV certified.

The AC500 PLC can also act as server for connection-oriented communication according to the Manufacturing Messaging Specification (MMS).

### **Easy engineering**

ABB Ability™ Automation Builder integrates the IED configuration which supports the import and export of files in the Substation Configuration Language (SCL) and code creation for the AC500. SCL allows transferring configuration information between various IEDs. The functionality of the devices can be programmed in IEC 61131 languages with Automation Builder.



**Integral solution**

All-in-one platform 60870-104, 61850, Modbus, combined with OPC DA, OPC UA, MQTT. Automation Builder Engineering with the comfortable IED configuration tool and flexible IEC programming functionality and C-code integration.

AC500 can interface to a large amount of IEDs and map their data in control and monitoring direction to a 60870-5-104 , OPC UA or MQTT communication as required or act on other IEDS e.g with advanced logic in load shedding control applications. AC500 can also help to modernize and digitalize an existing and aging infrastructure.

**Application example 61850**

AC500 can precisely control and monitor all levels (switchboard, substation and process) and connect them via 61850 or interface to the outside world (RTU).

Please watch our videos on our ABB PLC YouTube channel:



[www.youtube.com/user/abbplc](http://www.youtube.com/user/abbplc)

# AC500 application levels

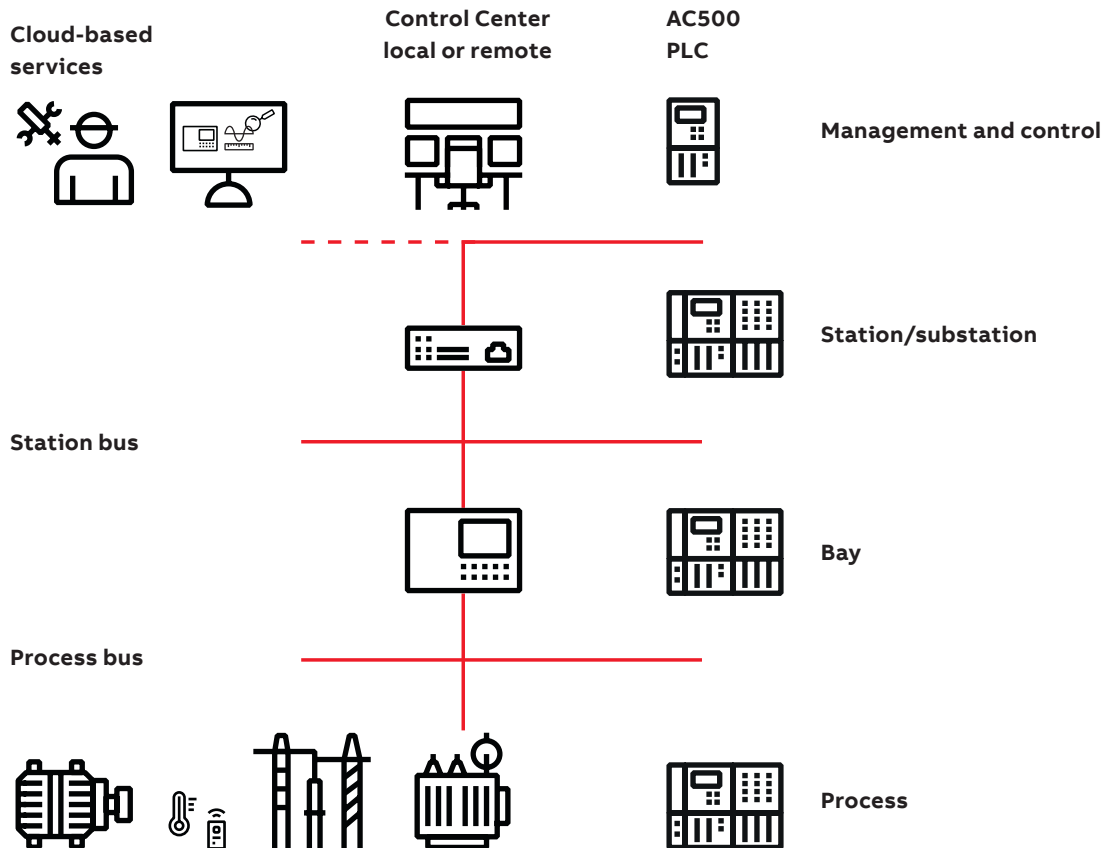



# Application descriptions

## Future-proof building automation with AC500

AC500 as freely programmable building automation controller

### Sustainability and profitability

Connecting the Building Automation Management System via AC500 to central and floor or room level functions guarantees efficient integration and best fit function of critical building systems, securing automation investment for the future. ABB's automation products can include control and monitoring of all up-to-date assets in a building like e.g. solar panels and integrate them to the energy management including e.g. storage and scheduling or shedding of loads. Overall this reduces consumption and maintenance costs, thereby considerably increasing the cost-effectiveness of buildings.

### Monitoring and control

In commercial buildings the reliable operation and control of critical functions like doors, access systems, escalators and elevators is important

for e.g. a safe and secure operation even in emergency situations. AC500 can also control, monitor and interlock the electrical switchboards as well as all subsystems and their functionality and provides valuable information in case of energy loss on some feeders or malfunction. It can enable monitored and available backup power systems to kick in and service personnel to respond and fix errors rapidly. In case of problems AC500 can manage emergency lighting and provide 24/7 availability to protect people in the building.

Access control and monitoring of charging stations in parking spaces is another asset of AC500 which can be included in the energy management and monitoring locally, remotely or via cloud services.

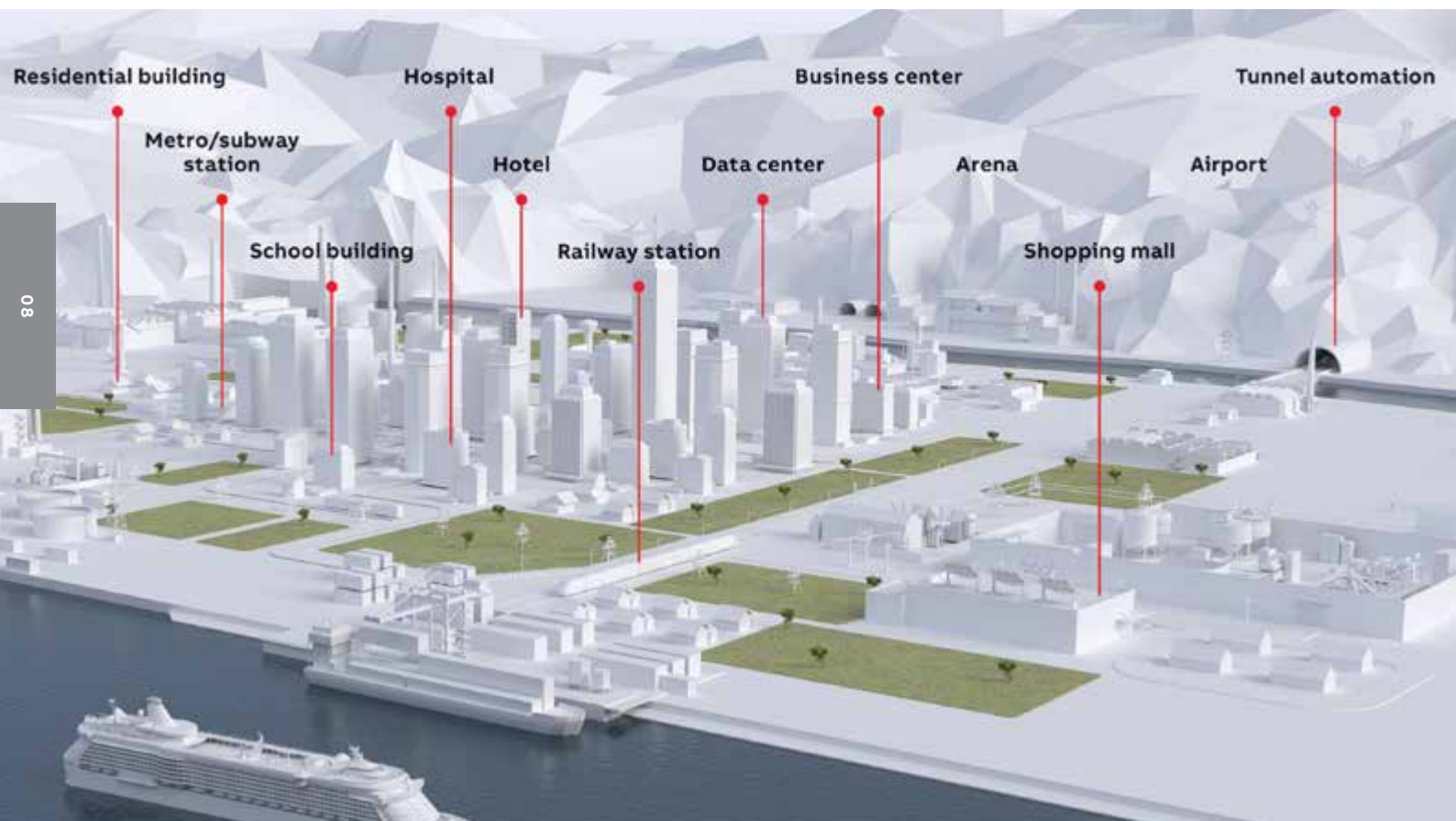

### Central HVAC, room and lighting management

ABB's KNX devices can control heating, cooling and lighting systems at room and floor levels and communicate directly also with central controllers like AC500. Such an integrated system can respond e.g. to sunshine thus ensuring optimal lighting and heating in every room individually, based on detected motion or absence in rooms. CP600 control panels can display the energy consumption of the individual rooms. Local or remote display is possible. With our integral solution, substantial energy savings can be achieved making your investment more profitable.

### Reliability and scalability

In critical building applications, such as data centers, hospitals, airports or railway/metro stations, reliability of the installed automation solution is key to a safe, productive and cost-efficient operation.

For example in a hospital, reliable function and uninterrupted power supply during surgery are essential for the safety of patients and their treatment. ABB's AC500 addresses these concerns by offering the required special features like multiple communications, high-availability as well as hot swap features. These features are vital to protect surgeons and patients from external impacts causing unforeseen downtime in the operation of the building automation system.

### Communication and openness

AC500 as an open communication platform can connect to Building Management Systems or field devices via various protocols, increasing usability, including OPC UA, BACnet (BTL certified) and KNX protocols beneath many others.

With the proven ABB i-bus® KNX system expanded by AC500, it is possible to automate all building automation functions and combine them via BACnet into a single solution with the Building Automation System across all levels.

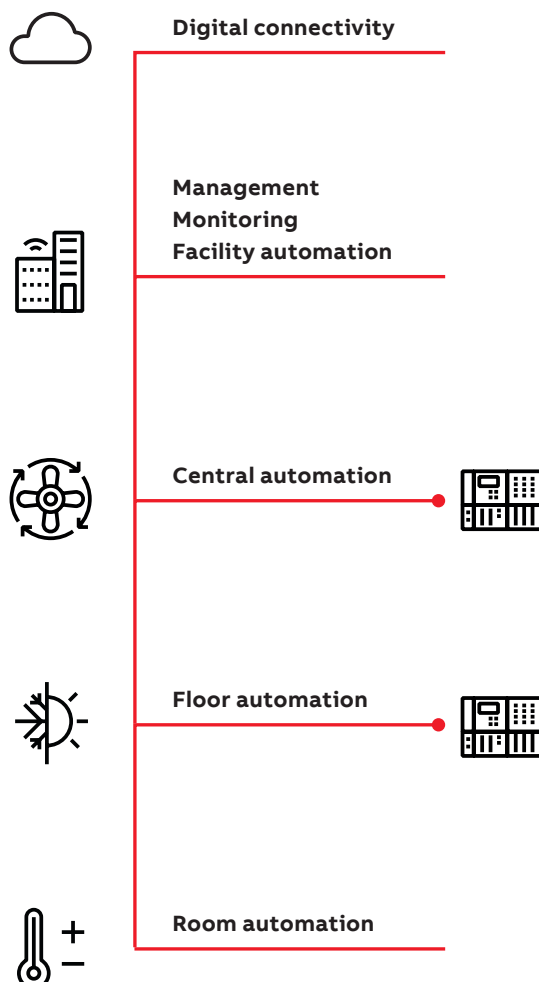

# Application descriptions

## Building automation with AC500, KNX and BACnet

AC500 as freely programmable controller, gateway or monitoring and visualization device

Use the AC500 PLC and S500 I/O for modular control e.g. for advanced energy efficient, safe and secure operation and monitoring tasks, from small to largest buildings.

Use the AC500 communication capabilities with other fieldbuses and protocols to connect, control and monitor the large portfolio of ABB components such as other low voltage products, ACS drives, motors, substations or connect them with building automation systems and the cloud e.g. with BACnet and OPC UA.

Use the AC500 and CP600 visualization capabilities for powerful local or remote monitoring across all levels.

Use KNX connectivity to add communication capabilities of the proven ABB i-bus® KNX devices like e.g. Dali, M-Bus etc. to the PLC automation level.

Everything in one system from room to central building functions, based on

- KNX and its efficient engineering by integration of ETS and ABB Ability™ Automation Builder.
- BTL certified BACnet (IP and MS/TP) with comfortable configuration in ABB Ability™ Automation Builder.

Easy creation and reuse of automation software in building automation by using the IEC 61131 standardized programming languages and library philosophies.

### HVAC application

Heating, ventilation and air-conditioning technology is made up of various systems, often spread on room, floor and central levels that can now be integrated into a single system with the same integrated engineering to enable optimization across all levels.

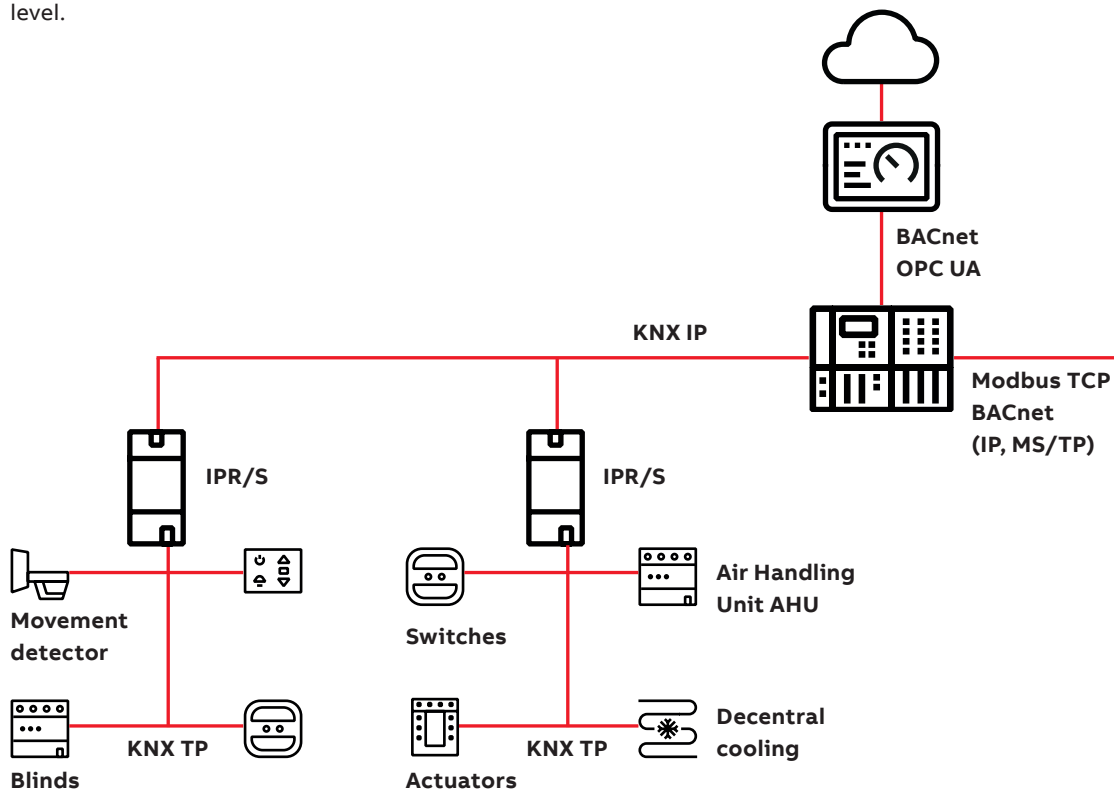

01 Integrated engineering workflow

01

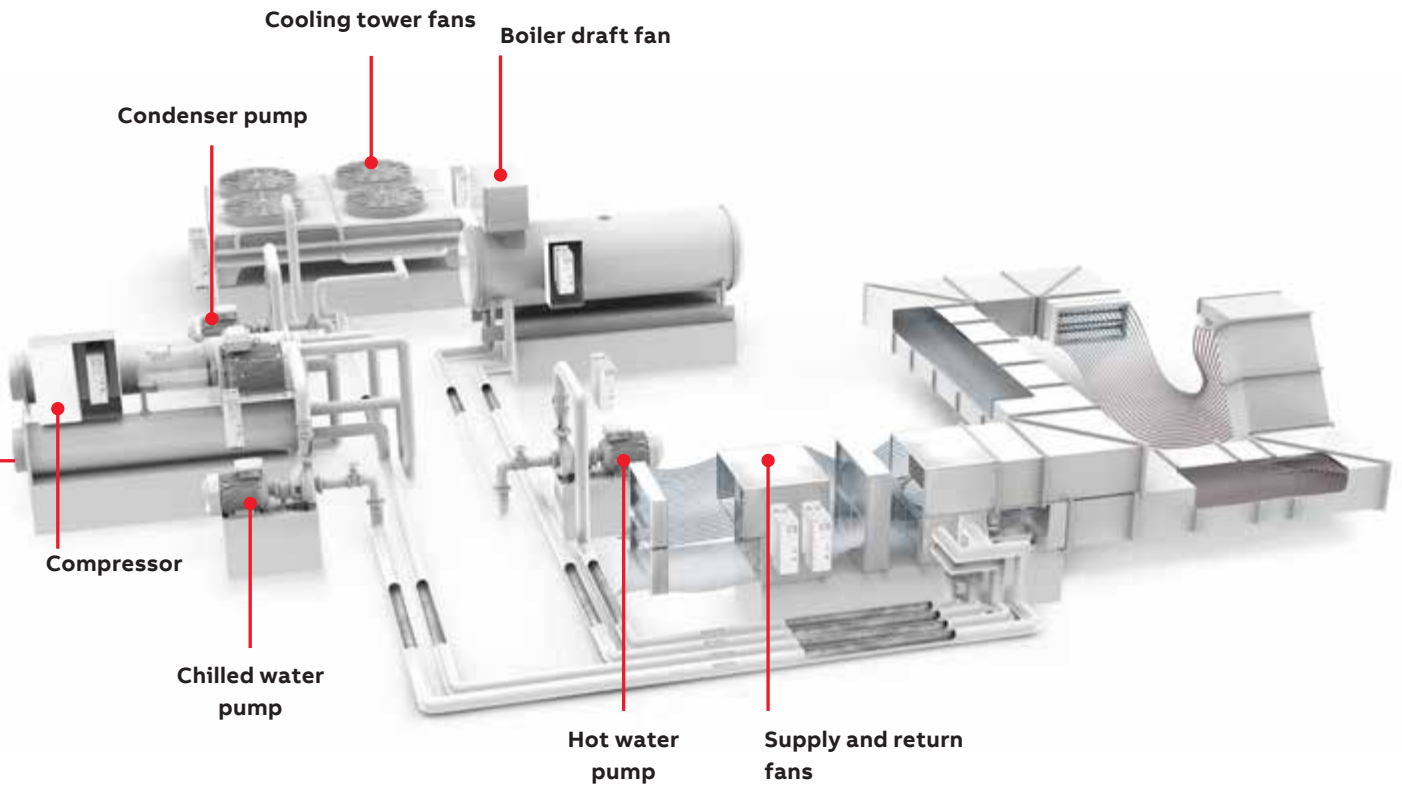
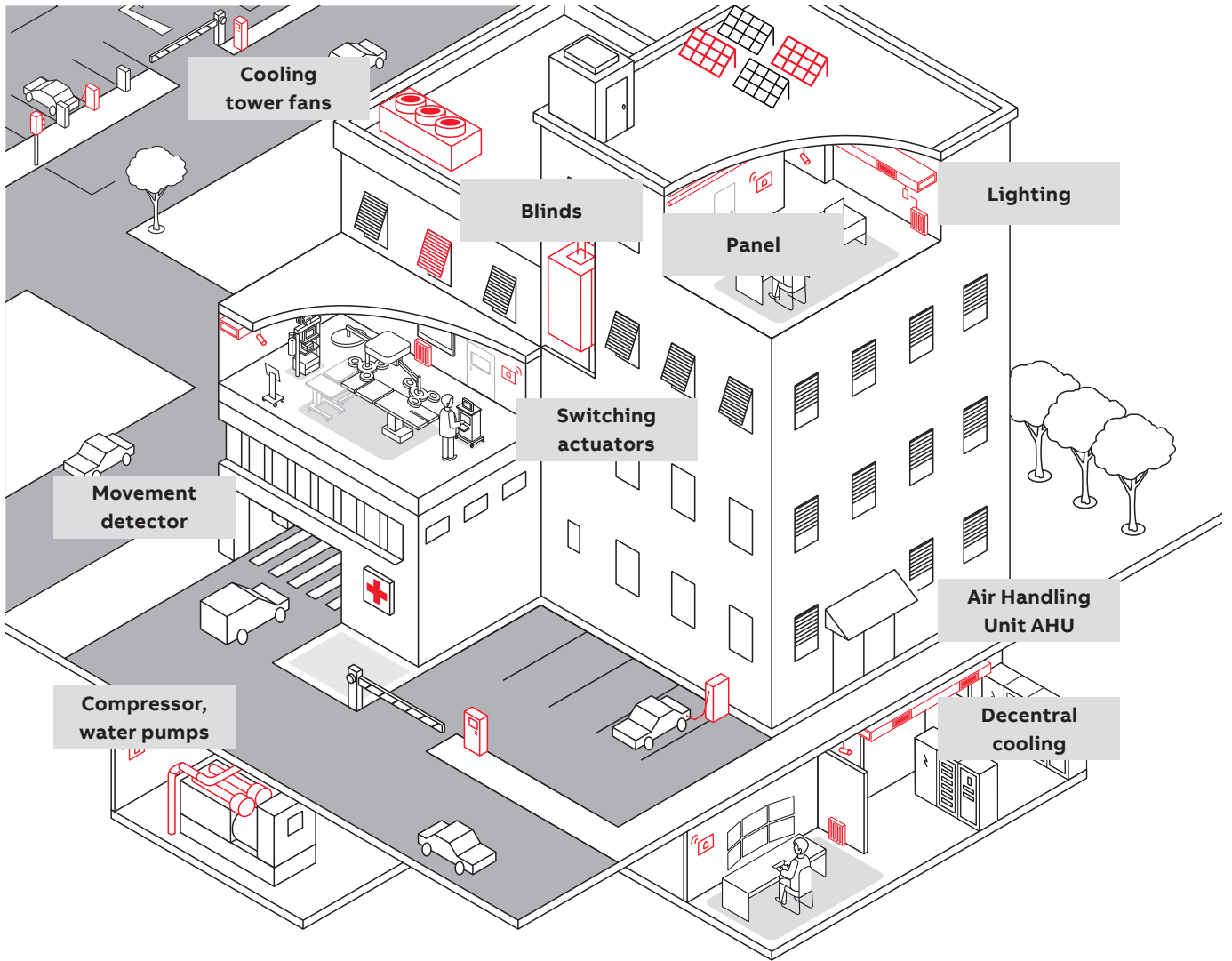

# Application descriptions

## Tunnel automation with AC500

ABB's core competence is proven by numerous tunnels globally - based on PLCs, HMIs, motors, drives and the ABB Ability™ Automation Builder integrated engineering suite. They are a perfect fit for tunnel applications, resulting in engineering productivity.

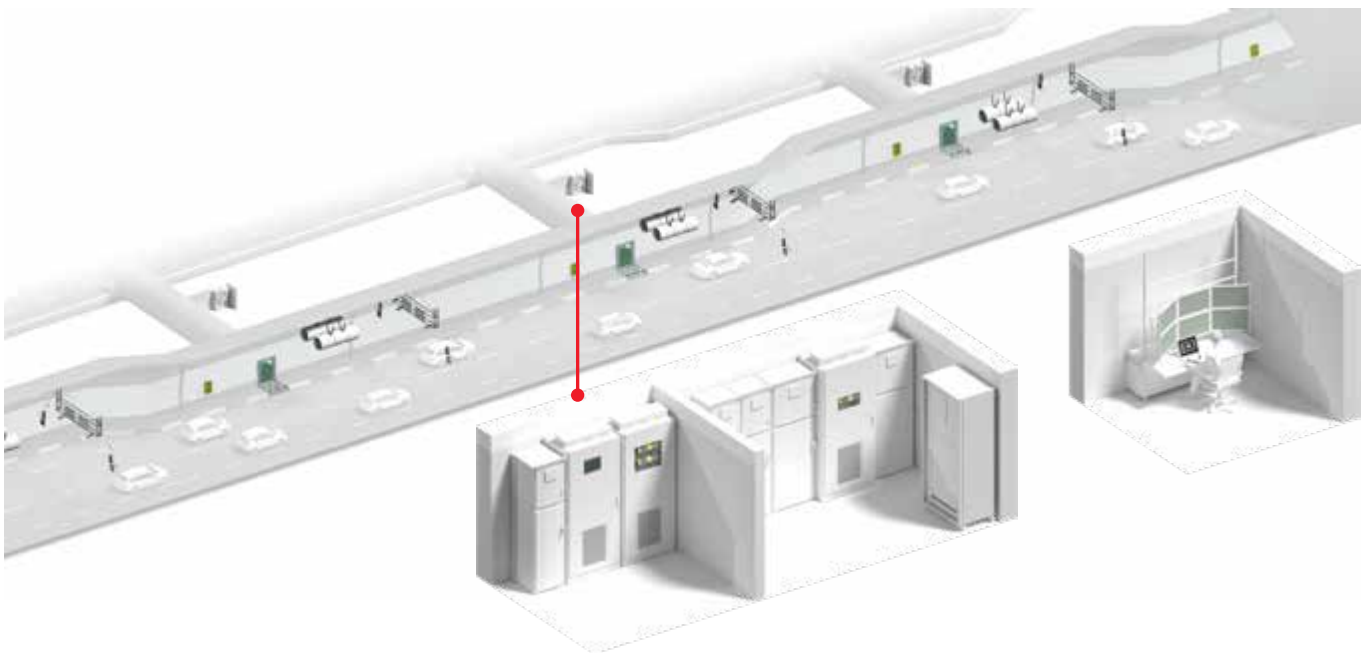

Tunnels are created wherever local conditions do not permit an efficient road or rail routes. They connect people by shortening travel times significantly, protect man and nature from noise and exhaust fumes and make remote areas accessible.

The safety standards for tunnels are regularly reviewed and adapted to the latest findings. New tunnels will be built and equipped on the basis of the most up-to-date and safe technologies and constructions, while older tunnels will have to be upgraded.

ABB offers a portfolio of higher-level control systems (SCADA) which act on top of the local ABB PLC-based architecture. All technical subsystems and field devices of the tunnel system can be controlled and monitored from one or several central locations.

ABB provides an end-to-end portfolio with a high number of scalable products and options, from the field layer right through to the management and visualization layers. This saves significant engineering time and money, while at the same time ensuring a highly available, safe and future-proof tunnel system.

Due to their scalability AC500 PLCs play a key role in tunnel automation. They can be used in all sizes of infrastructure projects ranging up to many tens of kilometers with hundreds of I/O stations distributed over the whole length of the tunnel.

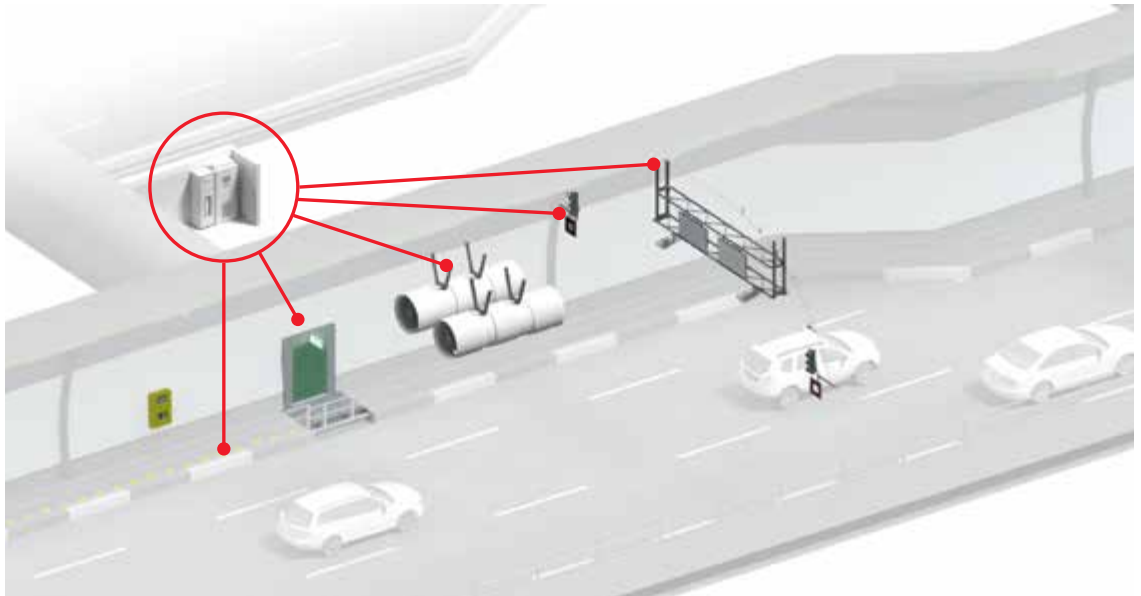

#### Protection and security

- Tunnel ventilation to protect people and equipment in every situation
  - Smoke extraction
  - Fresh air circulation
- Video and radar control to detect hazardous situations early
- Emergency evacuation system of the entire tunnel providing safe waiting spaces
- Modern lighting technology for safe navigation and good recognition of vehicles and passengers
- Manual call points along the exit routes
- Firefighting systems



#### Control and safety

- AC500
  - High availability
  - Safety PLC
- Drives for an optimal integration of the tunnel fans
- Suitable offers of control systems and switchgear
- Power monitoring
- Low-/medium-voltage distribution systems
- Emergency power supply



#### Communication and reporting

- Remote monitoring/IoT
- Remote maintenance
- General public announcement system
- Communication and notification system accessible from every point in the tunnel
- Optimized traffic flow with data acquisition via AC500
  - Signal systems
  - Changing traffic signs



#### Supervision and monitoring

- Local and higher-level control systems (SCADA)
  - Dashboards for an overview of the entire tunnel system
  - HMI CP600
- Energy management for the complete system
- Drive systems to efficiently operate tunnel ventilation

Please watch our videos on our ABB PLC YouTube channel:



[www.youtube.com/user/abbplc](https://www.youtube.com/user/abbplc)



# Application descriptions

## AC500 HA offers hot standby redundancy

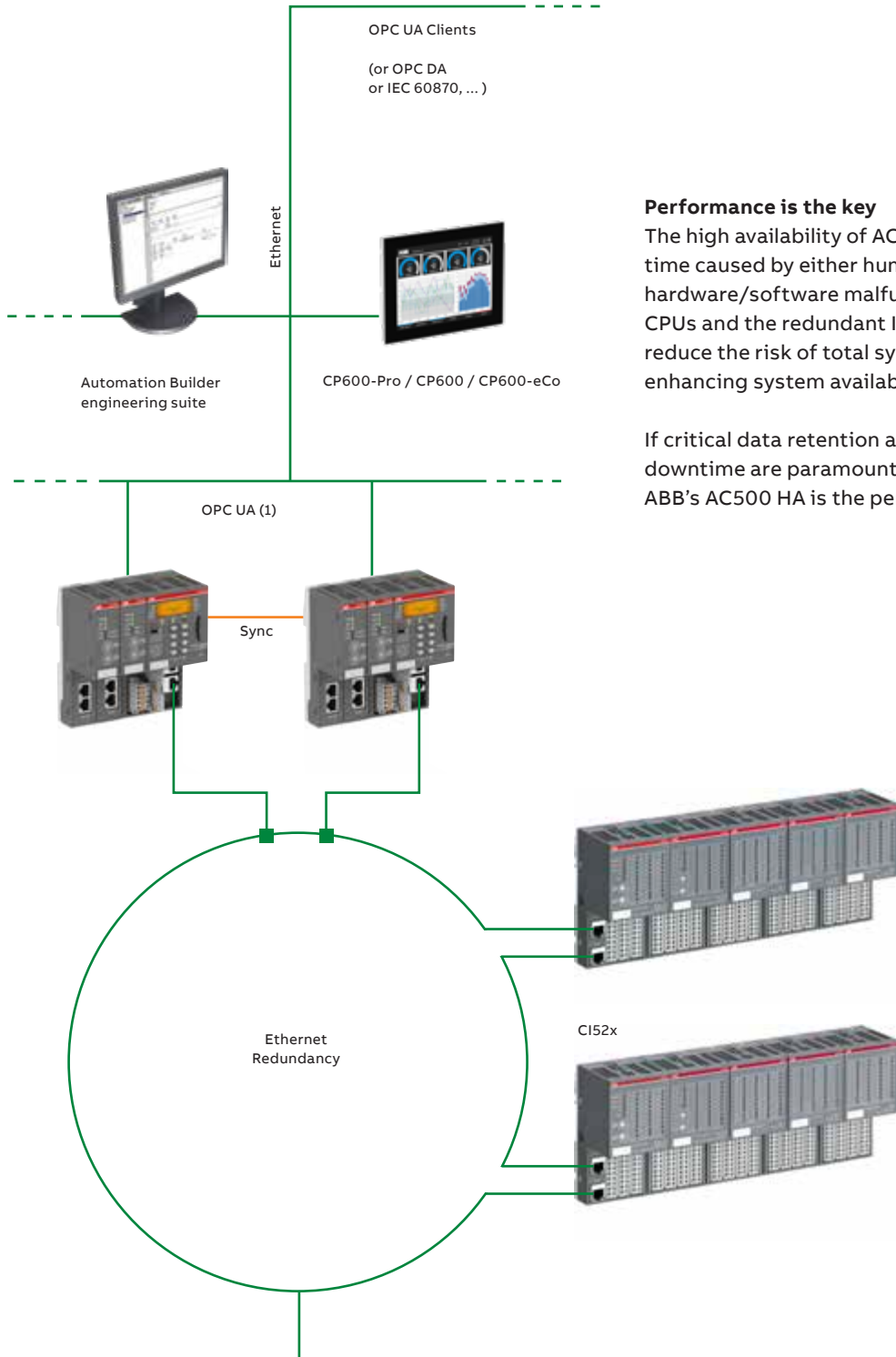

### Performance is the key

The high availability of AC500 HA prevents downtime caused by either human error or cabling/hardware/software malfunction. Redundant CPUs and the redundant I/O communication reduce the risk of total system failure, thus enhancing system availability.

If critical data retention and the avoidance of downtime are paramount to your application, ABB's AC500 HA is the perfect solution.

(1) AC500 V3 CPUs only



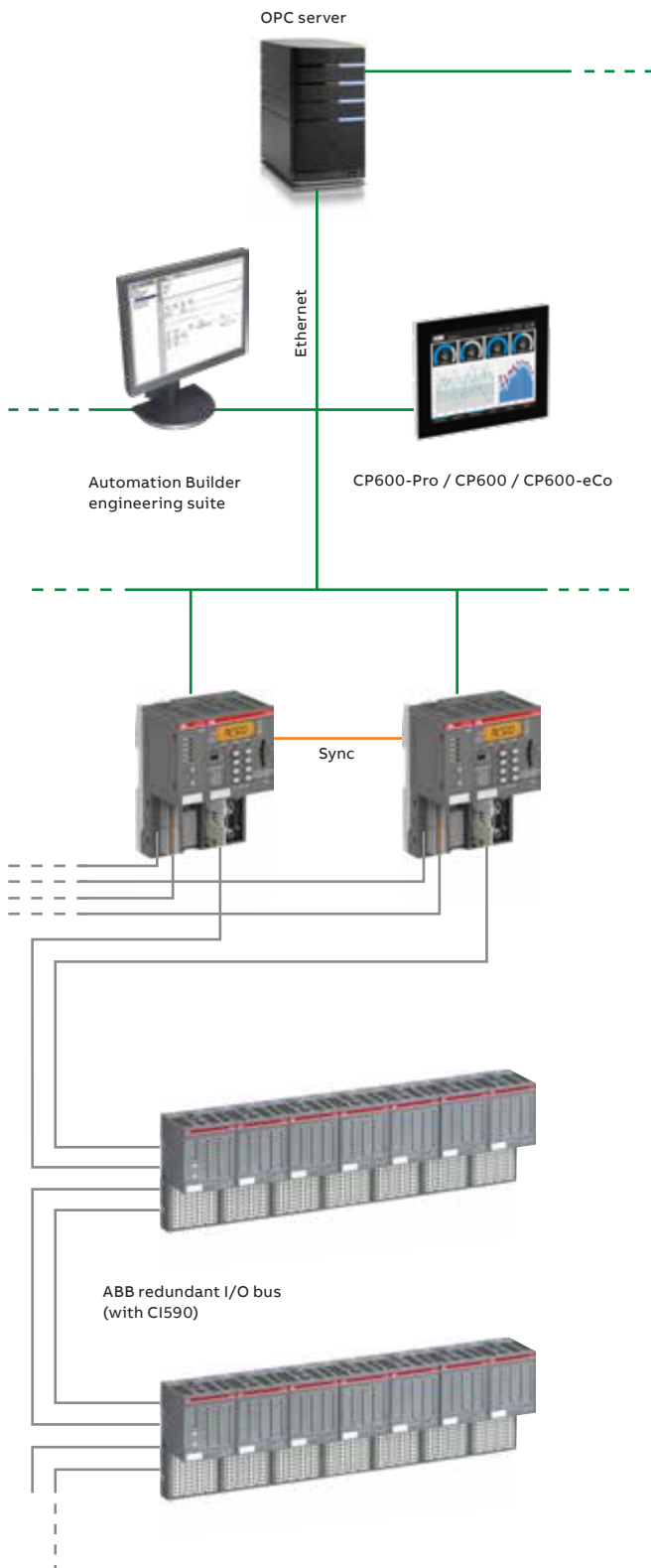

### What are the benefits of AC500 HA for your high availability solution?

- **Hot standby:** Both CPUs (and all communications) are hot: Permanently running in parallel, continuously synchronizing each other and monitoring the system. If the primary CPU is stopped, powered off or crashed, or if an I/O communication/cable has failed, the other hot standby CPU takes over immediately by adopting primary status.
- **Higher resource utilization, no downtimes** caused by cabling/hardware/software failure thanks to redundant CPUs and redundant communication to I/O and SCADA/HMI.
- **Cost efficiency and easy system maintenance** through the use of standard hardware.
- **High availability is provided with standard CPUs.** Cost matching hot standby quality for small or large systems.
- **Scalable in both variants:** CS31 redundancy bus or Ethernet.
- **Suitable for large distances** between redundant CPU (10th of kilometers).

# Application descriptions

## Hot Swap of S500 I/O modules for increased availability



### Replacing S500 I/O modules while the system is running

The hot swap terminal units TU516-H, TU532-H and TU542-H allow no-load hot swapping of S500 I/O modules during operation. When replacing a S500 I/O module the other modules in the cluster continue operating.

This capability is available for an I/O cluster with the following fieldbuses:

- PROFIBUS
- PROFINET
- Modbus TCP

Hot swap terminal units can also be used in I/O configurations attached to AC500 CPU modules.

Hot swap terminal units can be mixed with all normal terminal units (except safety terminal units) in the same configuration, when only specific modules need to be hot swapped.

The hot swapping feature is also available for extreme condition variants of S500.







#### Permanent wiring

Due to the construction of the S500 system, the wiring remains untouched during hot swap. There is no need to remove terminal blocks.

The S500 I/O module can be removed and replaced while the other modules in the configuration continue operating.

As soon as a module is re-inserted, it will be configured automatically and put into operation.

#### Applications

Hot swap is needed in hybrid applications when the control system must not be switched off during the replacement of a module.

# Application descriptions

## S500 I/O modules run with various controllers

### S500 remote I/O

The availability of different fieldbus communication interfaces makes it easy to use S500 I/O modules as remote I/O for nearly any PLC and PC. The S500 remote I/O station consists of a communication interface and I/O modules. The smallest configuration can be just the communication interface with the onboard I/O channels. Communication interfaces are available for the following fieldbuses:

- PROFIBUS
- PROFINET/PROFIsafe
- EtherCAT
- Modbus TCP
- CANopen
- ABB CS31 System Bus

### Easy engineering

The electronic configuration files that are provided by ABB for different fieldbus systems make it easy to configure the S500 remote I/O station in your engineering tool. The files such as GSD and GSDML are available for download at [www.abb.com/plc](http://www.abb.com/plc). For Modbus TCP remote I/O stations a dedicated configurator is included in Automation Builder and for larger applications a Bulk Data Manager tool can be used.

### AC500-eCo CPU as S500 remote I/O

When the AC500-eCo compact CPU is used as remote I/O, it can be programmed with Automation Builder for local intelligence while communicating via the open protocols Modbus TCP or Modbus RTU with a CPU that will then be the master of this intelligent remote I/O station. The AC500-eCo CPU can be expanded by I/O modules from the S500 and S500-eCo range.

Third party PLC, IPC or machine controller

Controller can also be an IPC with ABB Ability™ for data center

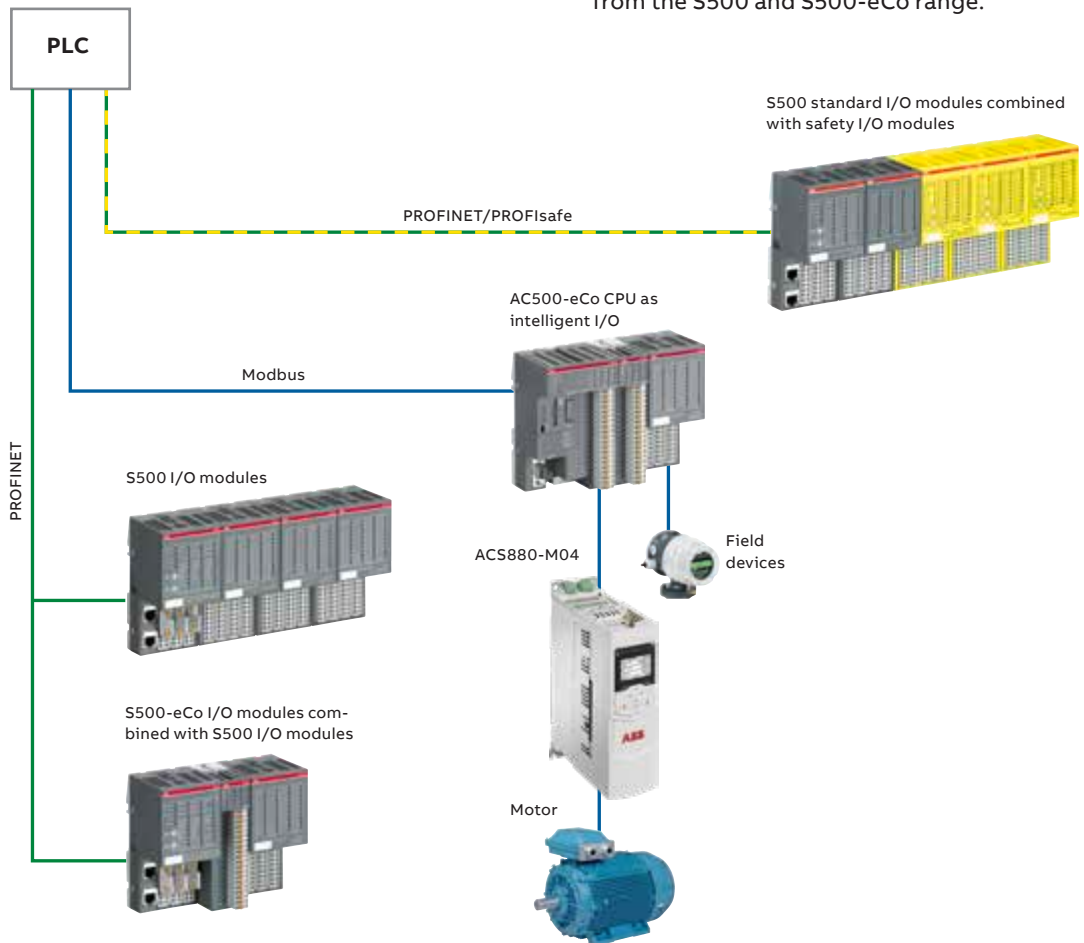

### S500 remote I/O with Modbus TCP

ABB provides a configurator in the Automation Builder tool, which allows the configuration of Modbus TCP I/O stations with the communication interfaces CI521-MODTCP or CI522-MODTCP in the same style as the AC500 configuration. For larger applications a Bulk Data Manager tool can be used. The configuration can be stored in the communication interface, which allows using the configured station with any PLC or PC that supports Modbus TCP. This e.g. allows the use directly on other controllers or monitoring systems as e.g. ABB Ability™ Data Center Automation or external systems.

Thanks to the Modbus feature that allows several masters to exchange data with the same slave, it is possible to use the I/O station as shared devices with up to 10 PLC CPUs.

The Modbus masters can access the process data of the I/O stations in two different ways:

- Fixed mode: each I/O module in the station uses a separate register address range, which requires separate Modbus read/write operations for the modules in the station.
- The dynamic mode allows to pack the data of all I/O modules in the station in one data structure that can be exchanged in one single read/write operation.

### S500 remote I/O with PROFINET/PROFIsafe

Simply extend your control system with ABB standard and safety I/Os to simplify wiring, reduce operating costs and benefit from the unique features of our safety I/O portfolio to increase the productivity of your machines.

For more information about safety applications, please see application description Embedding safety I/Os in ABB robots on page 250.

### S500 in hybrid applications with AC 800M Controller

The communication interfaces for PROFIBUS and PROFINET facilitate the integration of S500 as remote I/O stations in the System 800xA AC 800M family of controllers. System redundancy is supported with PROFINET. The configuration is integrated into the Control Builder M engineering tool.

Hot swap of S500 I/O modules is possible when these are mounted on hot swap terminal units.

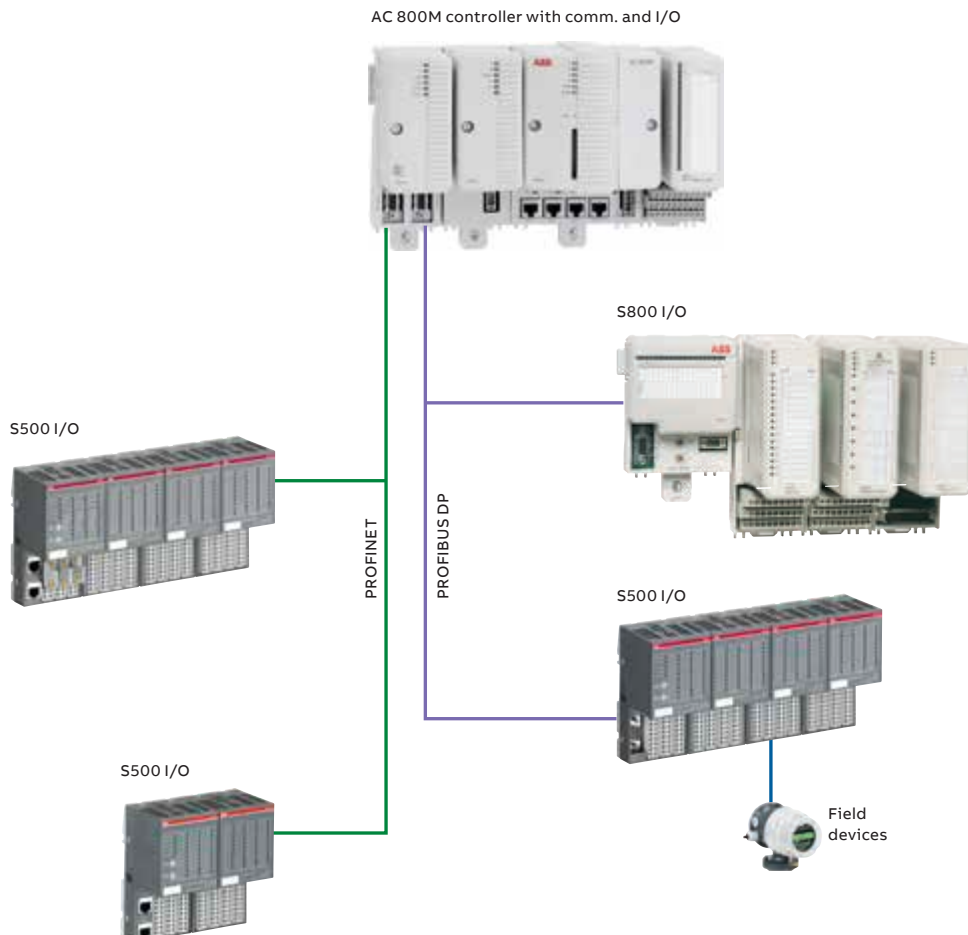



# Application descriptions

## Integration of AC500 PLC into ABB Ability™ System 800xA

### Integration of AC500 PLC into System 800xA

The AC500 PLC hardware can be used for automation of process modules while the operator benefits from user experience in System 800xA. Proven libraries are provided for System 800xA and AC500. This allows programming control tasks in the AC500 PLC while System 800xA is the operator interface. For large distributed projects, many AC500 PLCs can be connected to a System 800xA node.

### Process Control objects

Twelve objects are available which cover the following functionalities:

- Digital and analog setpoints
- Analog measurement with threshold alarm functions
- Valve control
- Motor control with or without variable speed drives
- Proportional integral controller

### Communication between System 800xA and AC500 PLC

Communication between the AC500 function blocks and the objects in System 800xA uses the PLC Connect option of System 800xA and the AC500 OPC Server.

### Simplified engineering

The Process Control Objects (PCO) library for AC500 V2 contains a function block for each object. The control task is engineered with the AC500 engineering tool ABB Ability™ Automation Builder. The communication between the objects in System 800xA and the function blocks in AC500 is configured with Bulk Data Manager, which is part of the System 800xA Engineering toolset. A library with ready-made symbols and faceplates for the objects is available for System 800xA engineering.

### Integrated documentation

For engineering, the function blocks for AC500 include the user documentation. The faceplates provide multi-language support for the text elements and allow adaptation of the color codes of the elements to the preferences of the application.

### Availability

The Process Control Objects Library (PCO) for AC500 V2 is available in Automation Builder. The Automation Builder installation also contains the required OPC server. The corresponding 800xA PLC Object Library for 800xA or Compact HMI can be ordered via the 800xA add-on features list.



—  
System 800xA and  
AC500 PLC network  
architecture



Network

Compact HMI for local operation

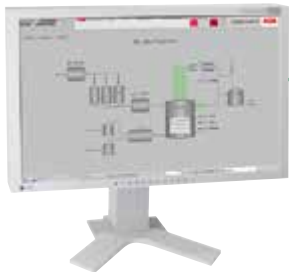

CP600 HMI  
for local operation



Control of process  
in AC500 PLC





# Application descriptions

## Condition Monitoring with AC500 PLC

### Controller integrated or stand-alone condition monitoring

The AC500 condition monitoring module FM502 is a natural part of the AC500 platform and ABB Ability™ Automation Builder, and can be used in different condition monitoring concepts, stand-alone or control integrated.

Due to the easy programming in PLC languages, it is usable for a variety of use cases and is especially suitable for plant, line and machine builders as easy extension of their offering.

If controller integrated

- it enables at very reasonable cost
- the best prediction horizon as it can measure online, when best measurement quality is given without scheduling production interruptions
- while continuously protecting the application in real time e.g. with the same or other sensor(s).
- Further inputs can be used as fast data logger e.g. precisely documenting process quality.

Therefore it is not only able to continually check the mechanical components but also gives fast protection for spontaneous and large failures even while measuring. The condition monitoring mode creates a database internally or externally for predictive maintenance. Automatic and user assisted responses can be enabled to prevent costly consequences including total failures.

As many as 16 vibration sensors + 2 encoder counters can be connected.

The recorded condition monitoring data can be stored in the CPU flash disk before communication or directly analyzed. Higher level indicators can be calculated and communicated to a local or remote HMI or database system.

### Predictive performance for your process or machines

- Easy and cost saving integration of condition monitoring into the AC500 platform.
- Early detection of mechanical damages.
- Fast protection from spontaneous failures.
- Even complex C-code analytics can be used locally for meaningful own performance indicators.
- Leads to optimized planning of maintenance instead of fixed, scheduled service and spontaneous repair.
- No additional system or fixed software for diagnostics and visualization needed.
- Easy storage of the data, locally (4GB) or in remote servers and databases.
- Ideally suited also for retrofit of older equipment, as it can make use of mechanical reserves of still valuable equipment.



— AC500 Condition Monitoring module FM502-CMS: Controller integrated or stand-alone CMS covering a complete drive train.

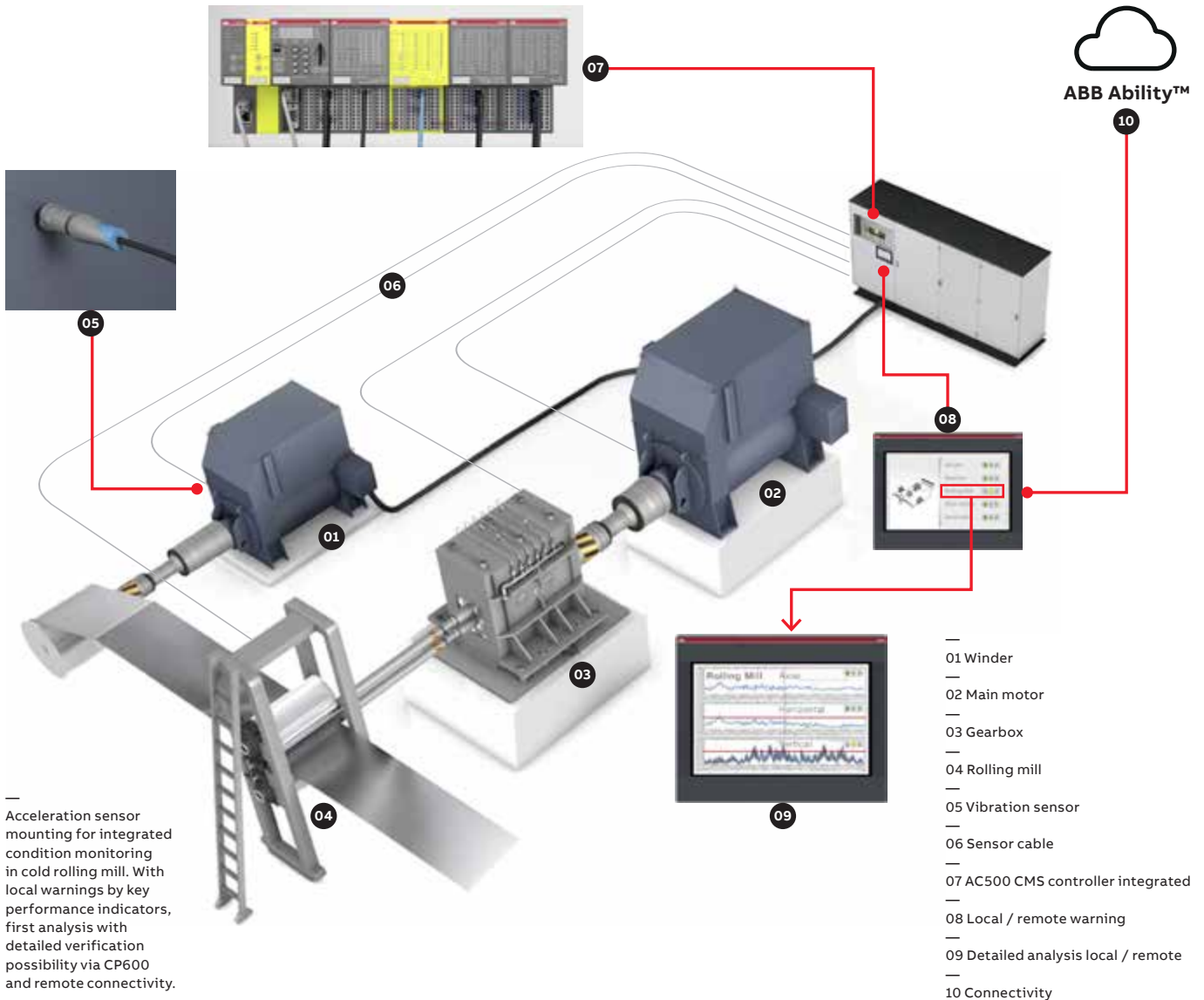
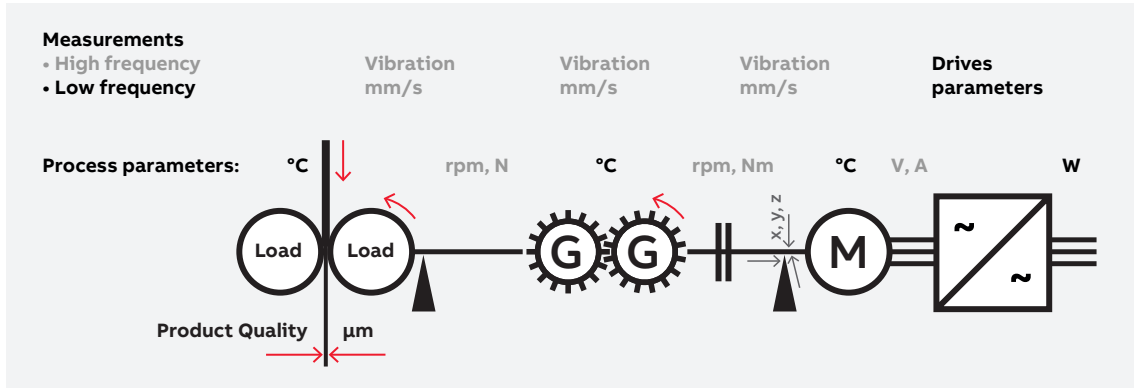

— Acceleration sensor mounting for integrated condition monitoring in cold rolling mill. With local warnings by key performance indicators, first analysis with detailed verification possibility via CP600 and remote connectivity.

**Example: Cold rolling mill in steel processing:**

- One FM502-CMS module can execute differently configured measurements at the same time and can be reconfigured at runtime.
- Several critical and unique components can be protected and condition predicted: Motors, gearbox, process (cold rolling mill).
- Production quality can be logged in parallel in real time.
- Remote diagnostics expertise and detailed analysis and reports only in case of warnings.

Please watch our videos on our ABB PLC YouTube channel:



[www.youtube.com/user/abbplc](http://www.youtube.com/user/abbplc)

# Application descriptions

## Machine controllers based on AC500 PLC

### From simple to high end motion applications

- Convenient PLC portfolio for diverse applications
  - Simple machine control with AC500-eCo PLC
    - Point-to-point motion with PTO outputs or Modbus communication with the drive
  - Mid-range applications with AC500 PLC
    - EtherCAT communication with the drive or remote I/O and cam-switch for synchronized motion
  - High-end motion application with PM595
    - Axis interpolation e.g. for Delta robot
- Easy integration and excellent scalability using ABB Ability™ Automation Builder
- Motion library for complex applications

### Multi-axis motion coordination with EtherCAT

ABB's AC500 PLC using EtherCAT real-time bus delivers high performance for multi-axis control applications.

The AC500 PLC provides an industry solution with IEC 61131-3 programming and PLCopen motion functions in combination with ABB drives such as ACS880-M04 fitted with the FECA-01 EtherCAT module for higher power axes or ACS380 drives or with MicroFlex e190.

This popular high-performance motion bus provides simple 'daisy chain' connection.

- EtherCAT multi-axis coordinated motion
- 01 AC500 PLC
- 02 CP600 HMI
- 03 Pluto Safety PLC module
- 04 MicroFlex e190
- 05 MotiFlex e180
- 06 ACS880-M04
- 07 ACS380
- 08 ACS880
- 09 S500 EtherCAT I/O
- 10 Third party CAN device

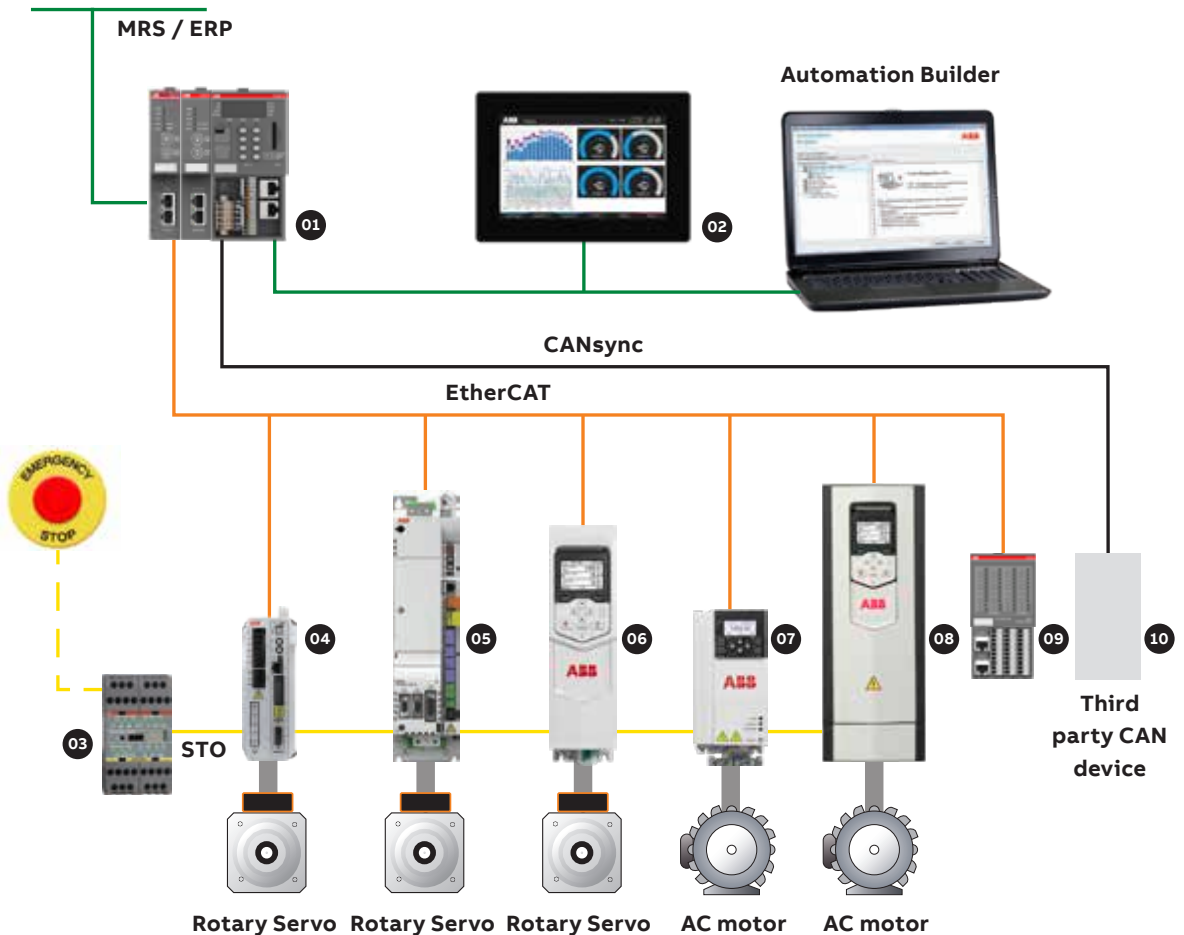

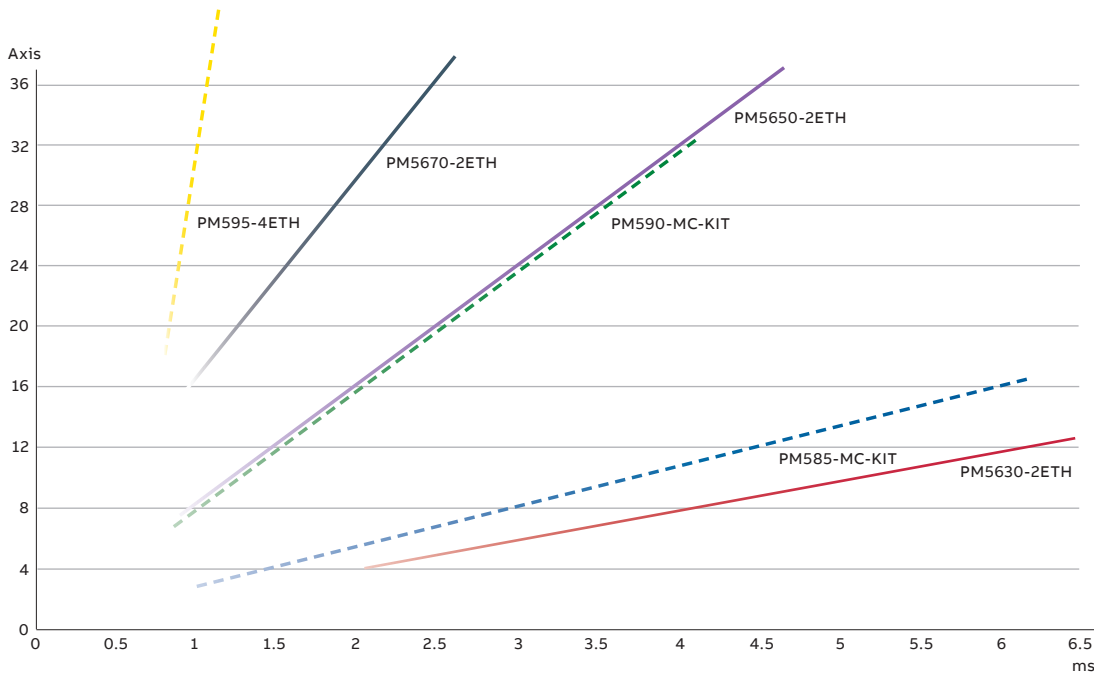

— 01 Number synchronized Axes / ms

**EtherCAT AC500 machine controller kits**

In order to simplify your application, ABB offers products for the implementation of machine control or motion control applications. These products can be purchased individually or as a kit. Two available EtherCAT kits contain the components required for your application.

Depending on the required performance, the kit provides a powerful CPU, an EtherCAT master communication module and the respective terminal base. The kit can be expanded using standard I/Os, other communication products or software solutions.

**AC500 Machine controller kits**

Program memory kB	Cycle time in $\mu$ s per instruction min. Bit/Word/Float. point	Integrated communication	Type	Order code	Price	Weight (1 pce) kg
1024	0.004 / 0.008 / 0.008	PM585-ETH, CM579-ETHCAT, TB511-ETH Ethernet (2), 2 x serial, EtherCAT Master	PM585-MC-KIT	1SAP140500R0379		0.500
2048	0.002 / 0.004 / 0.004	PM590-ETH, CM579-ETHCAT, TB521-ETH, TA524 Ethernet (2), 2 x serial, EtherCAT Master	PM590-MC-KIT	1SAP150000R0379		0.500

**AC500 CPU PM595**

Program memory MB	Cycle time in $\mu$ s per instruction min. Bit/Word/Float. point	Integrated communication	Type	Order code	Price	Weight (1 pce) kg
16	0.0006/0.001/0.001	2 x Ethernet (2 Ports switch), 2 x Ethernet (2), 2 x serial	PM595-4ETH-F	1SAP155500R0279		1.050

**AC500 V3 CPU**

Together with CM579-ETHCAT communication module, the AC500 V3 CPU can also be used for synchronized motion.

Total user program memory (5) / thereof user program code + data max. MB	Cycle time in $\mu$ s per instruction min. Bit/Word/Float. point	Integrated communication	Type	Order code	Price	Weight (1 pce) kg
8 (thereof 2 for User Prog. code + Data)	0.020 / 0.020 / 0.120	2 x Ethernet with configurable protocol Ethernet/IP (2)(3), 1 x serial, 1x CAN interface	PM5630-2ETH (1) (4)	1SAP131000R0278		0.135
80 (thereof 8 for User Prog. code + Data)	0.010 / 0.010 / 0.010	2 x Ethernet with configurable protocols Ethernet/IP (2)(3), 1 x serial, 1x CAN interface	PM5650-2ETH (1) (4)	1SAP141000R0278		0.135
160 (thereof 32 for User Prog. code + Data)	0.002 / 0.002 / 0.002	2 x Ethernet with configurable protocol Ethernet/IP (2)(3), 1 x serial, 1x CAN interface	PM5670-2ETH (1) (4)	1SAP151000R0278		0.135

(1) Ethernet communication provides integrated web server, IEC 60870-5-104 remote control protocol and OPC UA server on each interface independently. (2) In preparation (3) Some communication protocols are licensed. (4) Only to be used with dedicated terminal base TB56xx-2ETH. (5) Memory size of V2 versus V3 CPUs is not comparable. Projects have a different and separate User Program code and Data memory calculation in Automation Builder 2.4.0 version or later. System, configuration and web server parts are not counted anymore. This results in typically about 50 % lower memory usage compared to V2, and even lower memory usage compared to V3 projects compiled in Automation Builder 2.3.0 or before.

# Application descriptions

## Real-time Ethernet functionality

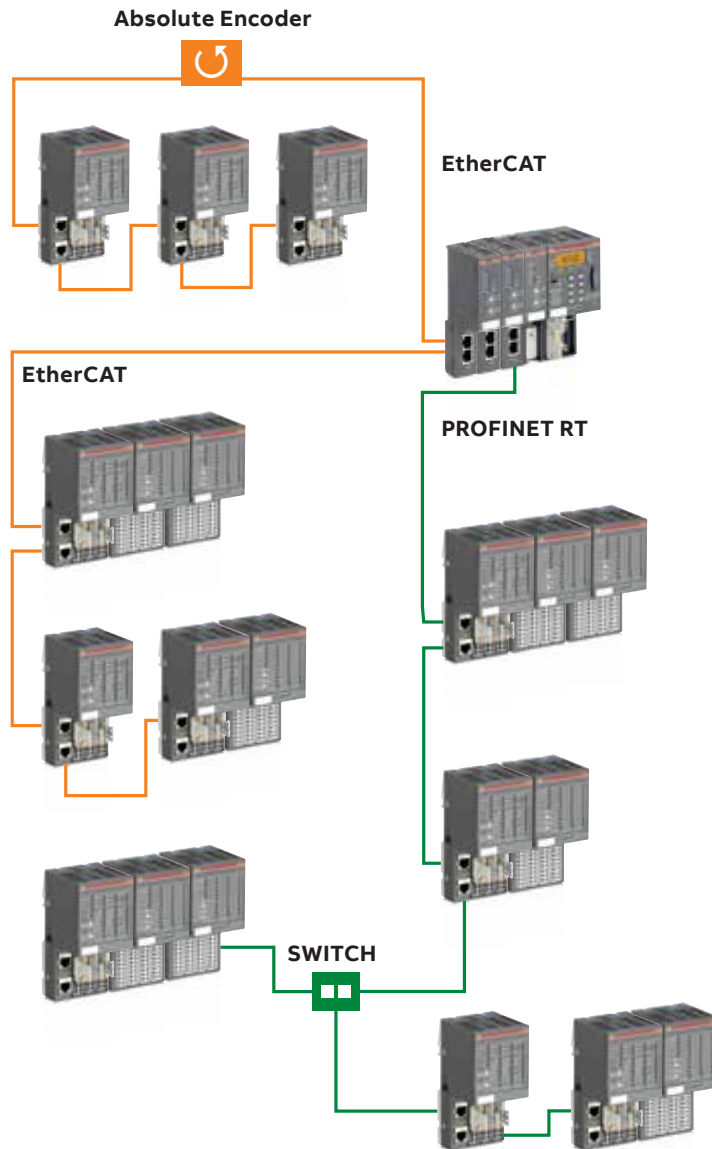

### RT-Ethernet modules

Modules are available with two different communication protocols based on Ethernet (PROFINET IO, EtherCAT). Master couplers connect AC500 CPUs to remote I/O modules. Various interface modules offer the connection of decentralized I/O modules to the real-time Ethernet networks.

### Cam-switch functionality

Modules based on the decentralized real-time EtherCAT interface technology with integrated I/Os and programmed with PLCopen function blocks are available.



# Application descriptions

## AC500 as advanced RTU controller



AC500 cloud demo



### Advantages of AC500 as RTU

AC500's open system architecture adds value to your applications: In addition to general logic capacity, it offers advanced pre-calculation and communication possibilities. AC500 CPUs and I/O modules fulfill requirements and offer features that are requested in industries where RTU units are used.

As an open communication platform, AC500 is compatible with IEC 60870-5-104, IEC 61850, OPC UA, MQTT and Modbus TCP. Furthermore, Ethernet protocols based on TCP/IP and UDP can be developed by the user. Protocols such as Modbus RTU, ASCII, PROFIBUS and PROFINET, among others, can be used for connection to devices and actuators.

### Applications and segments

AC500 has often been named the PLC of choice in the machinery, infrastructure and process industries.

### Programming and configuration

The Ability™ Automation Builder is the one and only tool for programming, configuring and communication.



One tool for the complete PLC Automation product family



IEC 61131-3 compliant



Six programming languages incl. C and C++ for solving complex tasks



A comprehensive set of ready-to-use libraries for time efficiency



Machine safety standards up to SIL3 or PL e can be combined to form an integrated safety solution

### Easy to handle with intuitive tools



Low-cost and power consumption, small footprint



Hot swap, network redundancy



Gateway functionality with telecontrol protocol



Versions for extended operating temperature from -40 °C up to +70 °C



Data collector and concentrator  
Data logging and data storage



MQTT cloud connectivity



HTML5 integrated WEB interface



Communication capability  
Modbus, IEC 60870-5-104,  
IEC 61850, OPC UA and more



Cryptographic tools and security functionalities

# Application descriptions

## Safer, greener and more productive with AC500-S safety PLC

PLCs with in-built functional safety and fail-safe condition monitoring are the unsung heroes of many renewable installations like wind turbines, electric battery-operated AGVs and hydrogen tank stations.

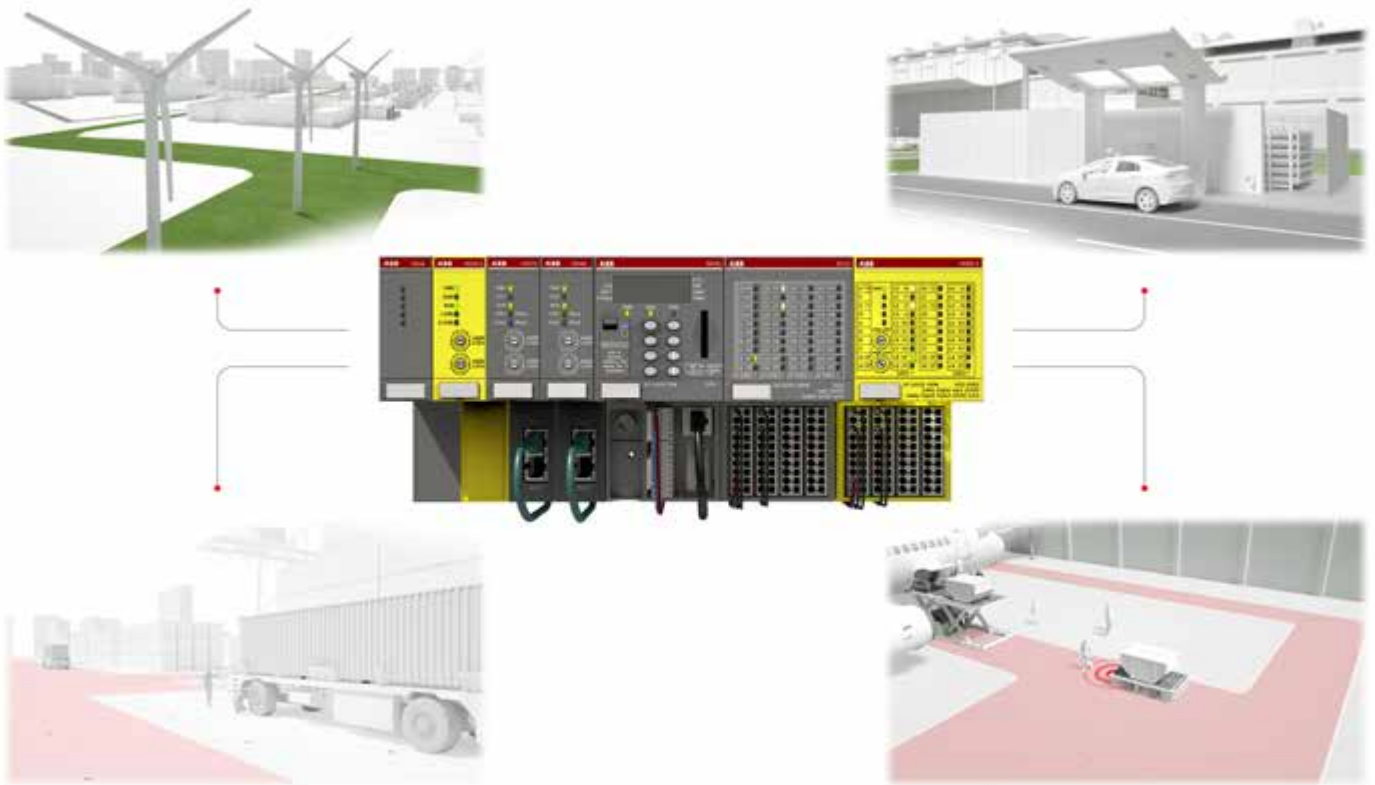

### A safety PLC plays an important role in renewable energy applications

Using programmable logic controllers (PLCs) to control wind turbines or direct solar arrays has been a common solution for many years. What is not yet fully appreciated is the failsafe condition monitoring and advanced functional safety capabilities built within today's PLCs and how they can be applied to renewable applications. Not everyone has grasped the importance that functional safety plays in renewable energy applications and the influential role that a safety PLC can play.

Renewable applications often require complex safety calculations driven by the need to process vast amounts of information to safely supervise the permissible range for temperature, pressure, charge rate, vibration level or position and speed tracking in real-time. Simultaneously, there is a need to safely monitor these complex renewable processes and/or machine characteristics. Ideally placed for this are safety PLCs, with support for trigonometric functions, floating-point calculations, PROFINET/PROFIsafe communication and structured text (ST) for safety programming.



### Wind turbines

Wind turbine safety is becoming increasingly important. In many countries, regulations stipulate that safety during wind turbine operation is critical to prevent accidents due to potential wind turbine collapse.

In addition to a state-of-the-art wind turbine safe control, the ABB AC500-S safety PLC with condition monitoring provides fail-safe condition monitoring of vibrations within the turbine's tower. This enables advanced safety functions to be implemented within wind turbines to avoid structural damage which could lead to accidents.

### Automated guided vehicles

Airports and harbors are becoming the epitome of green design, with shore-based wind turbines powering, for instance, the charging stations used to replenish electric battery-operated automated guided vehicles (AGVs) transporting goods.

The safety PLCs can restrict battery-operated AGVs to designated areas creating safe zones where workers can move about freely. Unable to enter these restricted areas, safety barriers no longer need to be able to withstand the full-force of an AGV, leading to a more open collaborative environment. In areas where the two must mix, the PLC can take input from the AGV's laser-scanner to safely stop the vehicle if it detects a worker or other object in its path.

The safety PLC provides floating-point calculations and trigonometric functions to implement even the most complex mathematical calculations in real-time. These include safely monitoring restricted safety areas for battery-operated AGVs and collision detection.

### Hydrogen tanks

To go further afield, people are increasingly turning to hydrogen fuelled vehicles to provide easy long-distance travel with much lower emissions than with conventional fuel like gasoline, gas, etc. Hydrogen is seen as an alternative to electric vehicles, featuring smaller batteries and generators, yet able to be used for longer distances. The key to this ease is the speed at which a vehicle can refill its tanks with this zero-emission fuel.

Critical to the safe operation of a hydrogen fuel tank is the need to precisely control the pressure and temperature. The tanks are packed with sensors monitoring these parameters and the PLCs provide fast processing speed to handle the large range of pressure and temperature calculations including safety functions like hydrogen leak detection, smoke detection, high pressure protection of inlet and outlet, etc. The fuelling stations use safety PLCs to precisely monitor the pressure, temperature and tank integrity, whilst providing controlled shut off of the safety valves in the event of a problem.

Please watch our videos on our ABB PLC YouTube channel:



[www.youtube.com/user/abbplc](https://www.youtube.com/user/abbplc)

# Application descriptions

## Embedding safety I/Os in ABB robots enhances man-machine collaboration

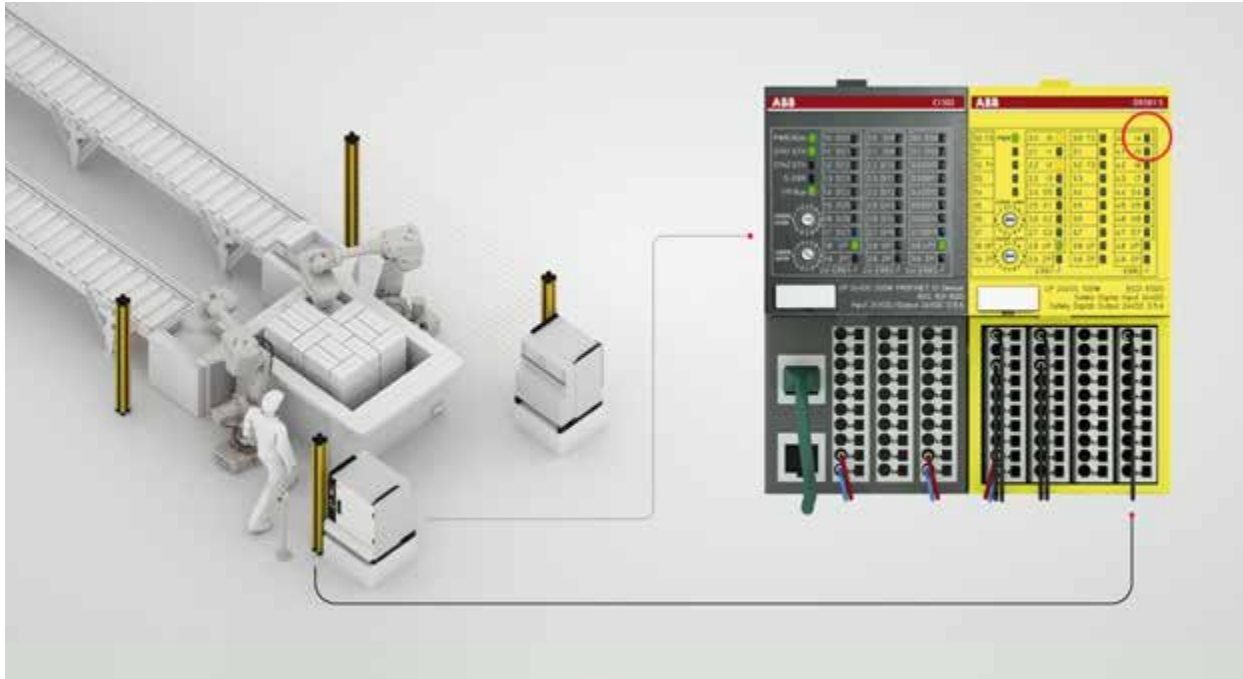

### Integration of safety I/Os

ABB is embedding S500 safety I/Os within its series of robot controllers to improve the flexibility, safety and reliability of collaboration between robots and people, which prevents unnecessary disruption to production. Simply extend your control system with ABB S500 safety I/Os to save wiring efforts, operation costs and use unique features of our safety I/O portfolio to increase your machine productivity.

A light curtain, laser scanner, safety mat, E-stop and acknowledge button, for example, are connected to ABB's S500 safety I/O module, which is integral to the ABB robot controller. Should a human enter the robot's cell to undertake maintenance, the safely-limited speed of the robot can be triggered, if permitted, as opposed to a safe stop. The robot moves very slowly and within

the pre-defined safe work zone using ABB's SafeMove2. Once the human leaves the cell, the robot can resume its faster operational speed with or without acknowledgement, depending on the used safety sensors.

### Cost-efficient solution

As the S500 safety I/Os are controlled by the safety module inside the robot controller, there is no need for third party stand-alone safety PLCs to be used. This saves costs as the combination of I/O and robot controller frees up space that would normally be needed for a separate cabinet. It also reduces the time associated with the set-up and operation of robotic production cells. This standardized solution leads to reduced spares, less wiring and lower operational costs as well as easy engineering through common diagnostics.

### Enhanced functionality

- More test pulse outputs on S500 safety digital I/O modules ensure higher degree of fault diagnostics and reaction, which results in higher safety integrity level for safety functions in the machine.
- Each safety I/O channel has not only process state LED but also fault-diagnostic LED which significantly simplifies maintenance work and, thus, save your operation costs.
- Extreme condition (XC) modules are available (-40 to +70 °C, high vibration and shock requirements, etc.), which allows cost-savings in engineering and operation.
- Fool-proof protection implemented in all safety I/O modules (reverse signal or power supply polarity, wrong module placement, short circuit etc.), to avoid damaged modules due to wrong wiring.

### More flexibility

- A single safety I/O channel can be individually reintegrated, which may provide higher machine availability in many customer cases.
- Front panel rotary switch for PROFIsafe address ensures less maintenance effort because you can see all pre-set PROFIsafe addresses directly looking at the front cover of safety I/O modules (no more need to disassemble safety I/Os).
- Built-in module power supply (no additional 24V DC power supply needed), which makes your power supply connections much simpler.

Please watch our videos on our ABB PLC YouTube channel:



[www.youtube.com/user/abbplc](http://www.youtube.com/user/abbplc)

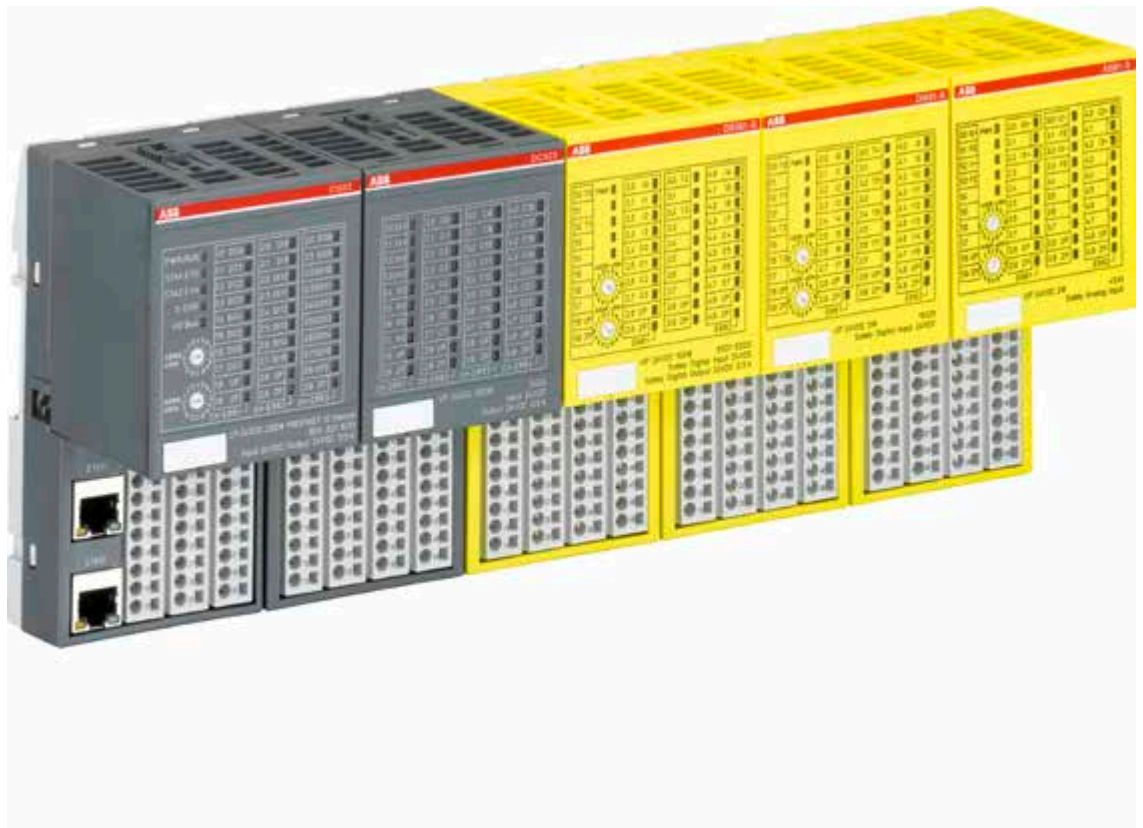

# Application descriptions

## Safe communication between safety CPUs using PROFINET/PROFIsafe over 5G

— 01 A modern distribution center comprises several independent systems including conveyor and lift systems, robotic sorting and palletizing processes, together with autonomous guided vehicles, or AGVs, and automated stacker cranes that lift pallets to and from the high bay storage systems. Each system needs to exchange its control and safety data via a central control system or distributed control system in an efficient and reliable manner so as to maintain productivity and minimize downtime.

### Real-time exchange of high volume process and safety data

ABB has moved from using just one central PLC controller to multiple controllers capable of communicating with many machines in real-time. Now each machine controller can exchange big volumes of process and safety data in real-time to more than one central control system simultaneously. 5G networks can also be used to wirelessly deliver time-critical data using PROFINET/PROFIsafe.

Safety CPU modules SM560-S-FD-1 (-XC) and SM560-S-FD-4 (-XC) can function as both a safety controller and a safety device. The modules, when used with ABB's AC500/AC500-S Programmable Logic Controller (PLC), feature the ability to exchange process and safety data, not only from one controller to multiple devices but also from one device to multiple controllers, using PROFINET/PROFIsafe shared device functionality.

Now hybrid interconnected PLC control systems can extend traditional centralized or distributed control. As such, each controlled machine can deliver high volumes of process and safety data in real-time, simultaneously, to several central control systems.

This solution replaces gateways which are expensive, take valuable control cabinet space and because they are limited to only 12 bytes of safety data per gateway, cannot communicate in real-time with large safety data volumes. With the new solution, a maximum of 1440 bytes of process data including up to 384 bytes of functional safety data can be allocated for up to four PLC controller systems, thereby providing faster reaction to optimize the production and improve the predictive maintenance that leads to less downtime.

— 01

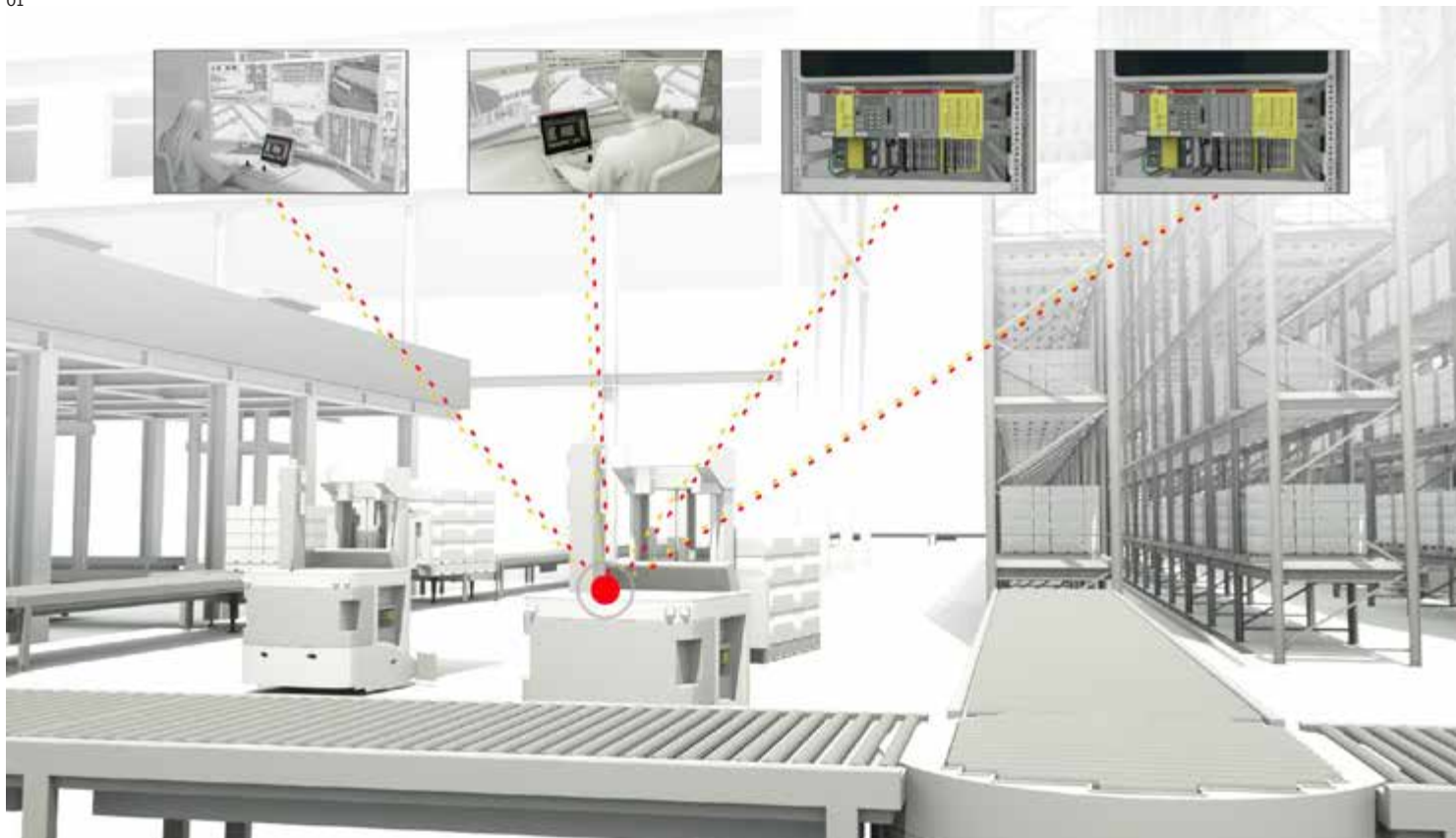

PROFINET/PROFIsafe communication between multiple AC500 PLC controllers

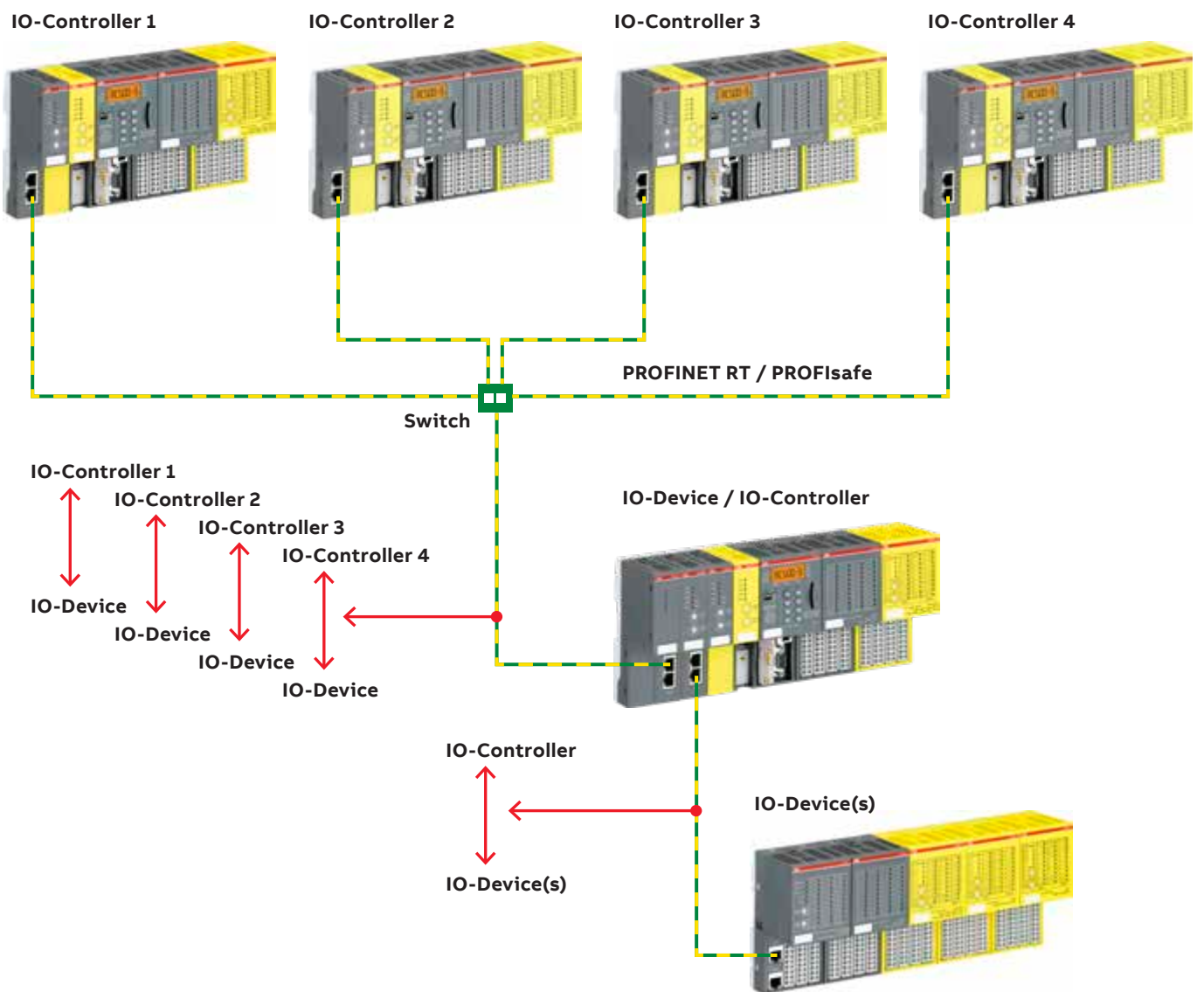

Please watch our videos on our ABB PLC YouTube channel:



[www.youtube.com/user/abbplc](http://www.youtube.com/user/abbplc)



# Application descriptions

## Triggering safety actions using standard HMI

With ABB's AC500-S safety PLC, standard HMIs such as control panels and mobile devices can be used to alter functional safety control functions in industrial applications. ABB has developed a method of using standard human machine interface (HMI) products such as control panels, industrial PCs and mobile devices to reconfigure safety control functions.

Using ABB's AC500-S safety PLC, operators of equipment such as harbor and factory cranes, hoists, elevators, airport passenger bridges, automatic guided vehicles (AGVs), robots, mining and pulp & paper machinery can select, modify and amend their safety control functions. This allows them to achieve functional safety standard requirements while benefiting from the convenience and low costs of using standard HMIs.

Operators of these industrial applications need to reconfigure their safety control functions to adapt to changed application conditions and to optimize machine productivity. These reconfigurations, known as safety actions, are often performed using mechanical or electro-mechanical mode selector switches connected to the digital safety inputs of a safety PLC.

This method suffers from limited user-friendliness, inability to make modifications to switch layout and function, limited number of selection options and relatively high costs for the mode selector switches and digital safety input channels.

ABB solves these challenges by allowing standard HMIs, such as control panels, industrial PCs and mobile devices to interface with an ABB AC500-S safety PLC to carry out these safety actions.





Please watch our videos on our ABB PLC YouTube channel:



[www.youtube.com/user/abbplc](https://www.youtube.com/user/abbplc)

Another example is in the selection of a crane, allowing it to be controlled remotely using the emergency stop located on the operator desk. A network links the AC500-S safety PLC in the control room with the safety PLCs at the cranes. The user in the control room can select, using standard HMI equipment, which of the cranes will stop if the emergency stop button is activated on the remote operator control station. Pressing the remote emergency stop button on the

operator's desk will therefore stop the selected crane only. Independent of the remote emergency stop function, all cranes still have their own local emergency stop controls.

The ability to select from a wide range of HMI products offers the user independence from any one vendor, a larger range of input options and greater flexibility to adapt the connections and layout of the HMIs.





# Cyber Security Information



## Introduction

Cyber Security is one of the most important topics for ABB and its customers. With the adoption of Industry 4.0 and IoT more and more devices are connected with each other. This is the reason why the security of industrial automation and control systems becomes more and more critical. ABB aims to protect the data, integrity and availability of all AC500 PLC products from I/O modules to the engineering software.

## How ABB PLC products meet security challenges

ABB takes all necessary measures to continuously improve the security of its products. These measures follow commonly accepted industry standards and practices and include, where technically feasible:

- Robustness testing, including fuzzing and flooding
- Vulnerability scanning for known vulnerabilities and exploits
- Security testing, including static code analysis or binary code analysis.

We highly recommend that all software, firmware, libraries and applications are kept up to date using the most recent firmware and software updates to keep your system and environment secure.

Before any deployment of standard and functional safety applications with ABB PLC products, an assessment for dangerous threats such as eavesdropping or data manipulation shall be executed. The security measures will depend on the selected security standard for the given application and implemented on the overall system level, for example IEC 62443-3-3 "Industrial communication networks – Network and system security" standard can be used.

## TÜV SÜD certification for IEC 62443-4-1

We are pleased to announce that TÜV SÜD has certified the site ABB Automation Products GmbH (APR) in Heidelberg in accordance to the **IEC 62443-4-1:2018** standard. The certificate is a confirmation that APR develops secure-by-design products in accordance to the IEC 62443-4-1 process.

Security for industrial automation and control systems - Part 4-1: **Secure product development lifecycle requirement** certificate.

## Additional information

For additional information and support, please contact your local ABB service organization.

For contact information, please write an email to [plc.support@de.abb.com](mailto:plc.support@de.abb.com)

Information about ABB's cyber security program and capabilities:

<http://www.abb.com/cybersecurity>

<https://new.abb.com/about/technology/cyber-security/alerts-and-notifications>

In addition, you will find the AC500 PLC cyber security white paper and the IEC 62443-4-1 certificate below this link:

<https://new.abb.com/plc/documentsanddownloads>



# PLC training and support Offering



ABB provides training and technical support guiding you to the ideal PLC Automation products for your applications. Supported by one of the world's most extensive global sales and service networks, we offer PLC and Automation Builder software training designed for engineering, operation and maintenance of PLC automation solutions.

Learn online through our video tutorials, eLearning, application examples or user forum and attend our classroom training sessions.

- ABB University course locator
- Application examples
- Channel partner program
- FAQ
- PLC on YouTube
- PLC Training and Support

For more information, please visit <https://new.abb.com/plc/training> or contact your local sales organization.

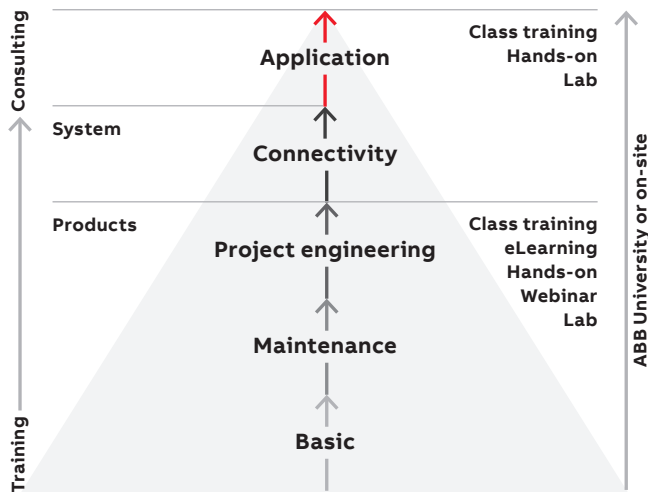

# PLC training and support

## Training cases

AC500 training cases help you to get familiar with ABB AC500 PLC offerings and the engineering tool ABB Ability™ Automation Builder.

For more information, please see <https://new.abb.com/plc/training>.

—  
01 AC500 training case  
For details, please  
see page 117.

—  
02 AC500-S training  
case  
For details, please  
see page 200.



01



02

Training cases	Description	Type	Order code	Price	Weight (1 pce) kg
AC500 V2 training case	PM585-ETH + TB521-ETH + CM579-PNIO + DA501 + CI502-PNIO + CP6607 + Case + 115-230 V AC power supply + Ethernet cables + demo program + memory card + simulation stand	TA515-CASE	1SAP182400R0002		7.0
AC500 V3 training case	PM5630-2ETH + TB5620-2ETH + CM579-PNIO + DA501 + CI502-PNIO + CP6607 + Case + 115-230 V AC power supply + Ethernet cables + demo program + memory card + simulation stand	TA5450-CASE	1SAP187700R0001		7.0
AC500-S safety PLC training case	SM560-S, DI581-S, DX581-S, AI581-S, TU582-S with PM573-ETH and PNIO	TA514-SAFETY	1SAP182900R0001		10.0

# PLC training and support

## AC500-eCo Starter kit

### AC500-eCo Starter kit

The AC500-eCo Starter kit helps you to get familiar with ABB AC500 PLC offerings and the engineering tool within a very short time. Learn how to connect and setup the components provided in the starter kit and how to program the PLC by means of several simple example applications. The starter kit comes with CPU, programming cable, digital input simulator and getting started manual. The latest version of the engineering tool Automation Builder is available via download.



### Easy to use

The AC500-eCo from ABB is a range of uniquely scalable PLCs offering you unrivalled cost effectiveness for modern industrial automation applications. The AC500-eCo integrates perfectly into the AC500 family - this provides you with the option to build customized solutions based on the standard S500 and S500-eCo I/O range.

### Easy to learn

Offering all of the advantages you would expect from the AC500 family of devices, the AC500-eCo delivers an impressive set of powerful programming features. In addition, thanks to the fact that ABB uses a standard IEC 61131-3 based programming system for the entire AC500 family, it is a snap to learn and configure.

### Ordering data

Each kit consists of CPU, programming cable and digital input simulator. The engineering tool is available for download at [www.abb.com/automationbuilder](http://www.abb.com/automationbuilder).

Starter kit	CPU module in the starter kit	HMI in the kit	Type	Order code	Price	Weight (1 pce) kg
AC500-eCo V2 Starter kit	PM554-TP-ETH	-	TA574-D-T-ETH	1SAP186200R0004		1.400
AC500-eCo V3 Starter kit	PM5032-T-ETH	-	TA5415-STAKIT (1)	1SAP187600R0002		1.400
	PM5072-T-2ETH	CP604	TA5426-STAKIT (1)	1SAP187600R0003		2.000

(1) In preparation

# PLC training and support

## Application examples

ABB Ability™ Automation Builder is the integrated engineering suite for machine builders and system integrators. ABB Automation Builder covers the engineering of ABB PLCs, safety, control panels, drives and motion. The application examples contain programming descriptions for different communication protocols and automation components.

### CI52x-MODTCP modules, configuration and communication

This application example describes the configuration (TCP/IP address and parameters) of the CI52x communication interface modules with Automation Builder. The second part describes communication with the configured modules and an AC500 PLC.

### AC500 BACnet IP, data exchange between 2 CPUs via the CP600 gateway

This application example demonstrates how to exchange data between PLC A and PLC B where both PLCs act as servers only. The trick is to use a CP600 panel as BACnet gateway. The panel acts as BACnet client.

### Cloud connectivity

This application example shows data publishing from AC500 to Microsoft Azure. It is not limited to the AC500 part, but also includes a configuration example of the required Microsoft Azure components.

### AC500 PROFINET, configuration and engineering

This application example describes how to configure and setup a PROFINET communication with Automation Builder V2.0.x. The detailed step-by-step instruction shows all necessary steps and describes the relevant parameters which have to be set carefully to establish a reliable and robust PROFINET communication.

The second part of this application example contains general information on e.g. cables, plugs, switches and network topologies which helps you realize your own PROFINET application project.

### Use of AC500 CMS filters

This application example explains in an easy to understand way how to filter measured signals in two different ways and calculate the RMS value with the filtered signal.

### AC500 license and IP protection for Codesys V2.3 libraries

The license protection of Codesys libraries aims at controlling the use of a library within the engineering context.

For more information, please use our new Application Examples Selector  
<https://new.abb.com/plc/application-examples>

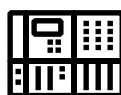

# PLC training and support

## Application notes

### Triggering safety actions using standard HMI

The application note describes the AC500/AC500-S system configuration, programming approach, safety calculation and requirements for standard HMIs for triggering safety actions using them. Standard HMIs that support at least two different Ethernet-based communication protocols can be used. ABB recommends Modbus TCP and ABB ETH. A mean time between failures (MTBF) greater than 22.5 years is required for standard HMIs to satisfy PL d (ISO 13849-1) requirements. HMIs with lower MTBFs may only satisfy PL c (ISO 13849-1) requirements.

### AC500-S safety I/O DX581-S with ABB safety relays BSR23

The application note provides technical details on using the DX581-S safety I/O module with ABB BSR23 safety relays for the potential-free switching of 6 A / 5A (24 V DC / 250 V AC) electrical loads, such as big safety contactors or safety valves by means the AC500-S safety PLC. Typical wiring examples and information related to safety calculations are included. Explanations of using the PLCopen safety FBs delivered with the AC500-S safety PLC in the safety application program to supervise the state of safety relay contacts are provided.

### Using DX581-S safety digital outputs with 2A 24 V DC electrical loads

The application note describes how the DX581-S safety I/O module developed for electrical loads with up to 500 mA 24 V DC can be used for switching 2A 24 V DC electrical loads such as big safety power contactors or solenoid valves. Details for wiring, channel configuration and safety calculation are provided.

### Cyclic non-safe data exchange between the SM560-S safety CPU and the PM5xx non-safety CPU

This application note describes the project configuration, programming details as well as verification and validation steps for the optional use of cyclic non-safe data exchange via DPRAM between the SM560-S safety CPU and PM5xx. A fast communication and/or transfer of large data volumes (> 84 Bytes) via DPRAM between the SM560-S safety CPU and the PM5xx non-safety CPU is needed in some customer-specific applications such as cranes, hoists, AGVs (automatic guided vehicles), etc. to synchronize process data on both CPUs. The solution described in the application note with SF\_CYCLIC\_PM5XX\_S\_SEND and SF\_CYCLIC\_PM5XX\_S\_REC FBs allows data exchange with up to 2 kByte of process data between a safety CPU and a non-safety CPU in every program cycle.

For more information, please visit <https://new.abb.com/plc/programmable-logic-controllers-plcs/ac500-s>

<https://new.abb.com/plc/documentsanddownloads>

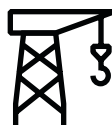
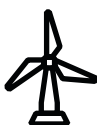



# AC31 adapter for retrofitting existing AC31 applications

## AC500 life cycle management

### A long history

During more than 40 years in the PLC business, we have gained experience from hardwired, centralized and distributed PLCs to scalable PLCs. One of our previous product ranges, the AC31 series 90, was succeeded by the AC500 PLC platform.

For the protection of your investments and for ease of migration to the new AC500 PLC generation, ABB provides AC31 adapter modules based on AC500.

The modules have the same footprint, cabling and features as the previous AC31 series 90 products with up-to-date AC500 hardware.

AC31 adapter modules can replace existing AC31 devices with either direct compatible e.g. I/O modules or need adjustments with a new user program for the CPU using Automation Builder software.

### Main characteristics and architecture

The connection locations do not differ from the predecessor hardware and the number or type of I/O channels are comparable. For remote I/O products on the CS31 bus, I/Os of an existing field application can be modified without having to change the application or configuration. New modules can be configured with DIP switches.

Replacing the AC31 PLC with the 07KT98-x-AD PLC requires to rewrite the application program using the Automation Builder engineering suite.

### Advantages at a glance

- Compatible with the existing AC31 series 90 remote I/O-modules, in some cases with 1-to-1 replacement in the field, no change of application configuration required.
- Footprint identical to predecessor hardware.
- Automation Builder for PLC programming.
- Standard AC500 modules for seamless migration from AC31 to the new AC500.
- Longer life cycle of AC31 through migration to new solution.

### Ordering details

For more information, please contact your local sales organization.

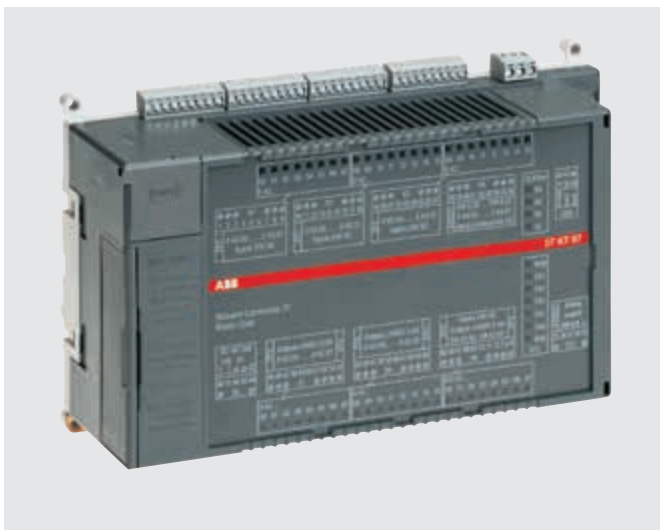



# AC31 adapter for spare parts

## AC500 life cycle management

Under certain conditions, the AC31 adapter I/O modules may be used as spare parts for existing applications where the previous AC31 modules were installed. The AC31 adapter modules can normally replace old modules without any changes in the configuration or application.

The new module is configured with DIP switches, the old one removed, the new one installed and the application started again.

The modules have the same footprint, cabling position and channel assignment. The AC31 adapter module supports most of the previous functionalities of the old module. There are only

a few exceptions and minor differences that are listed below:

- The AC31 adapter I/O modules can only be used, supported and tested with ABB AC31 master devices and cannot run with third party controllers.
- The AC31 adapter modules are based on standard AC500 I/O modules and on a specific electronic base, the modules cannot be purchased separately and are always delivered as complete devices. The pluggable electronic module cannot be replaced separately without the base.

For special applications, further details or specific questions regarding compatibility, please contact your local sales organization.



# AC31 adapter

## AC500 life cycle management

### Replacement table and compatibility information

Previous AC31 I/O module			New AC31 adapter module			Difference in feature / feature not supported
PN	Type designation	I/O combination	PN	Type designation	I/O combination supported	
GJR5251400R0202	07DC91	16DI/8DO/8DC	1SAP800300R0010	07DC91-AD	16DI/16DC	No local test button, compatible with basic diagnostics only.
GJR5252200R0202	07DC92	32DC	1SAP800500R0010	07DC92-AD	32DC	Same electrical potential for all channels (no group isolation), input current only max. 2 mA per channel, max. 8 A current sum for all outputs, no local test button, compatible with basic diagnostics only.
GJR5251600R0202	07AI91	8 AI, U/I PT100 and thermocouple	1SAP800200R0010	07AI91-AD	8AI	Standard analog voltage or current inputs, PT100/1000 only up to 3-wire connection, no thermocouple support, linear approximation always on, no test button, only standard as in 07AI91.
GJR5252300R0101	07AC91	16 AC or 8 AI/8 AO	1SAP800000R0010	07AC91-AD	16AO	No 16 AI inputs but only 16 AO in 16 AC configuration, no local test button, compatible with basic diagnostics only.
			1SAP800100R0010	07AC91-AD2	8AI/8AO	No local test button, compatible with basic diagnostics only.

### New AC31 adapter PLC module

PN	Type designation	Communication	I/O combination supported	Difference in feature / feature not supported
1SAP801400R0060	07KT98-ARC-AD	ARCNET	16DI/16DO/16DC/8AI/4AO	Programming using Automation Builder software means that old AC31 user applications must be re-written and direct import of the old program is not possible. Libraries are different and not all features are supported. Only PROFIBUS DP Master is supported. Same footprint and I/O channel position as old AC31 07KT98 CPU.
1SAP801100R0062	07KT98-ARC-DP-AD	ARCNET, PROFIBUS DP Master	16DI/16DO/16DC/8AI/4AO	
1SAP801200R0062	07KT98-ARC-ETH-AD	ARCNET, Ethernet TCP/IP	16DI/16DO/16DC/8AI/4AO	
1SAP801300R0072	07KT98-ETH-DP-AD	Ethernet TCP/IP, PROFIBUS DP Master	16DI/16DO/16DC/8AI/4AO	
1SAP801500R0062	07KT98-ARC-ETH-DP-AD	ARCNET, Ethernet TCP/IP, PROFIBUS DP Master	16DI/16DO/16DC/8AI/4AO	

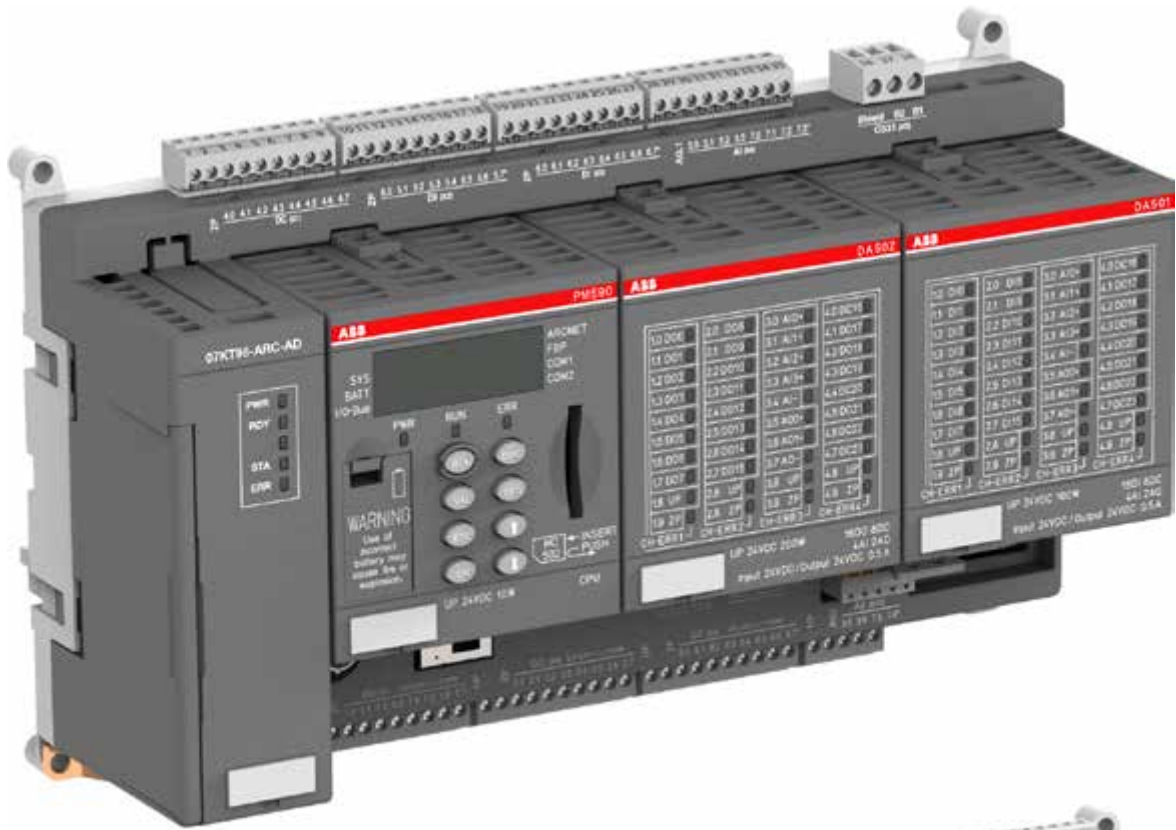

01 07KT98-ARC-AD



02 DC501-CS31-AD



03 07AC91-AD

# Additional information Services

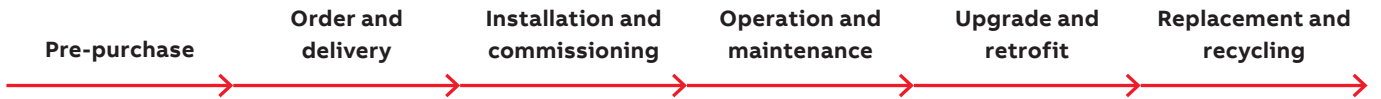

Services offered for ABB's automation products span the entire asset lifetime, from the moment a customer makes the first inquiry to disposal and recycling of the product. Throughout the life cycle of an asset, ABB provides training, technical support and customized contracts, supported by one of the world's most extensive global sales and service networks.

### Pre-purchase

ABB provides a range of services and support guiding the customers to the ideal products for their applications.

### Order and delivery

Orders can be placed at any ABB office or channel partner. In some countries, ABB also offers an on-line order tracking system. ABB's sales and service network ensures timely deliveries and also offers express delivery.

### Installation and commissioning

While many customers have the resources to perform installation and commissioning on their own, ABB and its channel partners also offer professional installation and start-up services if requested.

### Operation and maintenance

From maintenance assessments, preventive maintenance, reconditioning of spare parts and repairs on-site or in workshops, ABB has all the options covered to keep their customers' processes operational.

### Upgrade and retrofit

Frequently, ABB products can often be upgraded to the latest software or hardware in order to improve the performance of the application. Existing processes can be economically modernized by retrofitting with up-to-date technology.

### Replacement and recycling

ABB provides assistance in the best replacement of products while ensuring disposal and recycling observing the local environmental regulations.

# Additional information

## Life cycle management



### Product life cycle management model

ABB has developed a PLC life cycle management model aimed at providing proactive services for maximizing availability and performance. This model not only provides optimum support to end-users but also a smooth transition to a new product when the PLC has come to the end of its lifetime.

The life cycle management model divides a product's life cycle into four phases: active, classic, limited and obsolete. Each phase has different implications for the end-user in terms of services provided.

### Active phase

The active phase starts when the product is launched. In the active phase the end user benefits from different warranty options and other services such as training and technical support. Complete life cycle services from spare parts and maintenance are also provided. The active phase ends when the volume production of a particular PLC ceases and ABB issues an announcement of the life cycle phase change.

### Classic phase

ABB PLC users continue to benefit from complete life cycle services throughout the classic phase. The classic phase is closely aligned with ABB's research and development work to provide continuing support for its PLC products while developing future generations. In the classic phase new hardware and software development may be required to provide the maintenance techniques and upgrades needed to guarantee that the PLC continues to operate at its peak performance. Migration to a new PLC product is recommended before the product has entered the limited phase.

### Limited phase

In the limited phase the product development has come to its end. Spare parts are available as long as components and materials can be obtained. Towards the end of the limited phase, services gradually become obsolete. In addition to the annual life cycle status reviews, ABB issues a life cycle phase change announcement, half a year prior the product becoming obsolete. This is the last opportunity to transfer to new technology before product services end.

### Obsolete phase

The product is transferred to the obsolete phase when it is no longer possible to provide services at reasonable cost or when ABB can no longer support the product technically or the old technology is not available.

### Benefits of life cycle management

PLC life cycle management maximizes the value of the equipment and its maintenance investments by:

- ensuring spare parts and ABB competence availability throughout the lifetime
- enabling efficient product support and maintenance for improved reliability
- adding functionality to the initial product by upgrading or retrofitting
- providing a smooth transition to new technology at the end of the product lifetime.

For more information, please see [www.abb.com/plc](http://www.abb.com/plc) or contact your local sales organization.



# Additional information

## ABB Ability™ Automation Builder product life cycle plan

### Product life cycle

ABB is committed to supporting our customers' installed system base. We want to optimize our customers' system investment and provide our customers with the confidence that there is a well-defined support and a path forward for existing ABB systems. ABB's product life cycle policy provides advanced notification of planned changes in product availability and support.

This chapter shall not be understood as legally binding. Users are recommended to keep informed about updates by periodically checking relevant life cycle information.

### Predictive releases – continuous delivery

ABB continuously maintains and improves its software products. As part of this effort, we develop and release major versions, minor versions and service releases.

Major and minor releases focus on new features whereas service releases deliver corrections and quality improvements. A new service release supersedes and replaces existing service releases within the same major/minor release. All releases contain corrections to issues either identified in ABB test labs or reported by our customers.

Release Type	Designation example	Purpose and frequency
Major Release	1.x, 2.x	Deliver new features extending Automation Builder scope
Minor Releases	1.1.x, 1.2.x	Deliver new features within current Automation Builder scope
Service Releases	1.2.1, 1.2.2	Deliver corrections, improvements and updates of existing components

ABB aims for continuous, consistent and coordinated delivery of engineering tool versions and device firmware versions. It is recommended to always use the latest release of Automation Builder.

### Version profiles – compatibility with installed base

ABB aims at maximizing availability and performance of the installed base. In this effort we

follow these two principles: The engineering tool shall provide the latest features in best quality. The engineering tool and installed base shall always be compatible.

To meet these requirements Automation Builder introduced version profiles. A version profile contains all Automation Builder software components as released in the latest service release of a specific major/minor version, including respective device firmware versions.

Version profiles can be installed with every release of Automation Builder. Multiple version profiles can be installed in parallel. Each version profile goes through all product life cycle phases. Life cycle statements apply to each version profile and corresponding licenses. The availability of a version profile depends on the life cycle phase it is currently in.

All this allows our users to install the latest version of Automation Builder and keep compatibility with the installed base. Updates of the runtime system are avoided. The latest Automation Builder release always contains the best quality for all profiles. Corrections are distributed via releases and not via hard to track patches.

### Automation Builder life cycle management model

The Automation Builder life cycle management model aims to provide service for maximizing availability and performance, support to end-users and a smooth transition to new product versions when the service life of the current product ends. The model divides a product's life cycle into four phases: active, classic, limited and obsolete. Each phase has different implications for the end-user in terms of software and license availability, services and support provided.

<b>Active</b>	The software product with complete life cycle services is available.
<b>Classic</b>	The software product with complete life cycle services is available for system extensions and spare part engineering.
<b>Limited</b>	The software product is available without maintenance and further corrections. Migration to a newer version is recommended.
<b>Obsolete</b>	Migration to a newer version is recommended.

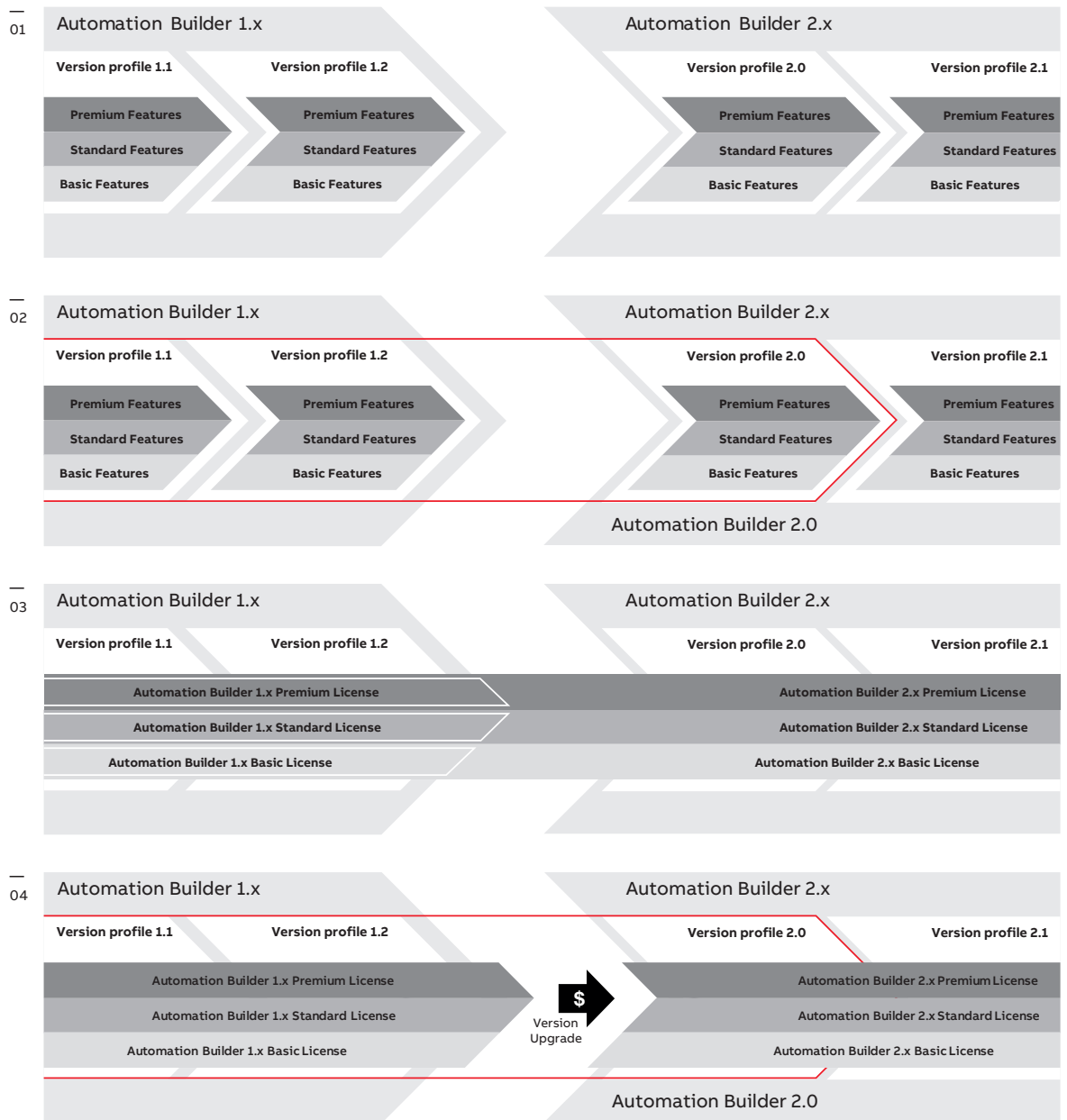

### Version profiles and licenses

01 – Major versions come in several minor versions, e.g. Automation Builder 1.x comes as Automation Builder 1.1 and 1.2. Version profiles cover different sets of features, e.g. basic, standard and premium feature sets.

02 – An Automation Builder release contains multiple version profiles, each corresponding to a released minor version. E.g. release Automation Builder 2.0 contains version profile 2.0, 1.2, 1.1 and more.

03 – To use a feature a license is required. The license defines which feature set can be used, e.g. a premium license enables you to use the premium feature set. A license corresponds to a major version of Automation Builder, e.g.

Automation Builder 2.x Premium license enables to use Premium features in all 2.x minor versions and in all previous versions.

04 – There are two different cases where you have to purchase a new Automation Builder license:

- Edition upgrade: Need for a higher value license option within the same major version of Automation Builder, e.g. Automation Builder 2.x Premium instead of Standard.
- Version upgrade: Upgrade from one major Automation Builder version to another, e.g. Automation Builder 1.x to 2.x. – Note: Licenses for Automation Builder 1.x and Automation Builder 2.x can be used in parallel in order to support different version profiles.



# Additional information

## ABB Ability™ Automation Builder product life cycle plan

### Life cycle phases

#### Active

A newly released version profile of Automation Builder starts in life cycle phase Active. During the Active phase the version profile is available with complete life cycle services.

This means the version profile is available via Automation Builder installation manager from abb.com and will receive ABB's normal product maintenance including enhancements and corrections, and third party software updates.

The version is the base for current sales and active price list. Licenses can be purchased. Support and training is provided.

#### Classic

With release of the next major/minor version the predecesing version profile is going into life cycle phase Classic. During the Classic phase, the version profile with complete life cycle services is available for system extensions and spare part engineering.

Classic version profiles are available via Automation Builder installation manager from abb.com and will receive corrections only for critical issues. Classic version profiles are typically available as released in the latest respective service release (and additional corrections). New 3<sup>rd</sup> party products (e.g. OS) are not supported anymore.

Licenses can be purchased. Training is not available anymore. Support is provided.

#### Limited

During the Limited phase, the version profile is available without maintenance and further corrections. Migration to a newer version is recommended.

This means it is no longer available from Automation Builder installation manager from abb.com, but could be obtained as offline installations via support. Corrections might be available upon request as billable service. New 3<sup>rd</sup> party products (e.g. OS) are not supported anymore.

Licenses can be purchased. Training is not available anymore. Support is provided.

#### Obsolete

When entering the Obsolete phase, the version profile is not supported anymore. Migration to a newer version is strongly recommended.

This means it is not available anymore for installation. It will not receive corrections anymore.

Licenses can be purchased. Training is not available anymore. Support is not available anymore.

# Additional information

## Generic composition of type designation



The identification number starts with 5 for the AC500 PLC platform or 6 for the CP600 HMI platform.

### Example: AC500-eCo central processing unit

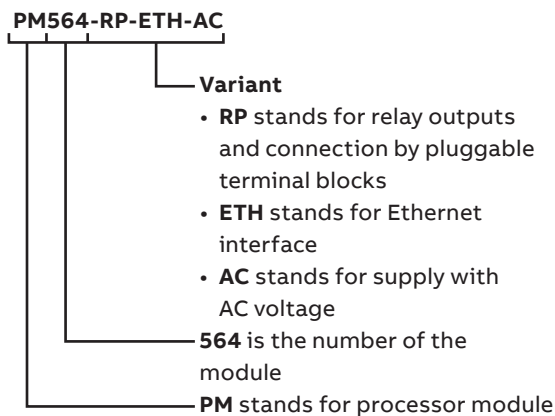

### Prefix of module types

Letters	Meaning
<b>AI</b>	Analog input module
<b>AO</b>	Analog output module
<b>AX</b>	Analog input/output module (X stands for mixed input/output)
<b>CD</b>	Counter module
<b>CI</b>	Communication interface module for remote I/O station
<b>CM</b>	Communication module attached to the CPU
<b>CP</b>	Control panel (HMI)
<b>DA</b>	Mixed analog/digital input/output module
<b>DC</b>	Digital I/O module with channels configurable as inputs or outputs
<b>DI</b>	Digital input module
<b>DM</b>	PLC engineering software ABB Ability™ Automation Builder or add-ons
<b>DO</b>	Digital output module
<b>DX</b>	Digital input/output module (X stands for mixed input/output)
<b>FM</b>	Function module
<b>MC</b>	Memory card or memory card adapter
<b>PB</b>	Panel Builder engineering software for HMI
<b>PM</b>	PLC CPU module
<b>PS</b>	Application-specific function block libraries
<b>SM</b>	Safety CPU module
<b>TA</b>	Accessories and training cases
<b>TB</b>	Terminal base for CPU modules
<b>TF</b>	Terminal base for CPU with function modules
<b>TK</b>	Communication cable
<b>TU</b>	Terminal unit for I/O modules

# Additional information

## Certifications

**Symbols and legends:**

- Standard product certified: product label wears approval mark when mandatory
- Submitted (roadmap available upon request)
- Submission planned (roadmap available upon request)
- Submission not planned or not applicable for product

Name	Conformité Européenne	UKCA UK Conformity Assessed	SJ/T 11363-2006 (China RoHS)	Regulatory Compliance Mark (RCM)	Eurasian Conformity	Korea Certification	Underwriter Laboratories	American Bureau of Shipping	Bureau Veritas	DNV-GL	Lloyds Register	RINA	Russian Maritime Register of Shipping	Korean Register of Shipping	China Classification Society
Logo / Certification Mark															
Certificate	Declaration of Conformity LVD / EMC	Declaration of Conformity	Declaration of Conformity	Declaration of Conformity	Declaration of Conformity	Declaration of Conformity	cULus Ordinary Locations	cULus Hazardous Locations	Design Assessment	Type Approval	Type Approval	Type Approval	Type Approval	Type Approval	Type Approval
07AC91-AD	●	○	●	–	●	–	●	–	–	–	–	–	–	–	–
07AC91-AD2	●	○	●	–	●	–	●	–	–	–	–	–	–	–	–
07AI91-AD	●	○	●	–	●	–	●	–	–	–	–	–	–	–	–
07DC91-AD	●	○	●	–	●	–	●	–	–	–	–	–	–	–	–
07DC92-AD	●	○	●	–	●	–	●	–	–	–	–	–	–	–	–
07KT98-ARC-AD	●	○	●	–	●	–	●	–	–	–	–	–	–	–	–
07KT98-ARC-DP-AD	●	○	●	–	●	–	●	–	–	–	–	–	–	–	–
07KT98-ARC-ETH-AD	●	○	●	–	●	–	●	–	–	–	–	–	–	–	–
07KT98-ARC-ETH-DP-AD	●	○	●	–	●	–	●	–	–	–	–	–	–	–	–
07KT98-ETH-DP-AD	●	○	●	–	●	–	●	–	–	–	–	–	–	–	–
AC522	●	○	●	●	○	●	●	●	●	●	●	●	●	○	–
AC522-XC	●	○	●	●	○	●	●	●	●	●	●	●	●	○	–
AI523	●	○	●	●	●	●	●	●	●	●	●	●	●	○	●
AI523-XC	●	○	●	●	●	●	●	●	●	●	●	●	●	○	●
AI531	●	○	●	●	●	●	●	●	●	●	●	●	○	○	●
AI531-XC	●	○	●	●	●	●	●	●	●	●	●	●	○	○	●
AI561	●	○	●	●	●	●	●	●	●	●	●	●	●	●	–
AI562	●	○	●	●	●	●	●	●	●	●	●	●	●	●	–
AI563	●	○	●	●	●	●	●	●	●	●	●	●	●	●	–
AI581-S	●	○	●	●	●	●	●	●	●	●	●	●	●	○	–
AI581-S-XC	●	○	●	●	●	○	●	●	●	●	●	●	●	○	–
AO523	●	○	●	●	●	●	●	●	●	●	●	●	●	○	●
AO523-XC	●	○	●	●	●	●	●	●	●	●	●	●	●	○	●
AO561	●	○	●	●	●	●	●	●	●	●	●	●	●	●	–
AX521	●	○	●	●	●	●	●	●	●	●	●	●	●	○	●
AX521-XC	●	○	●	●	●	●	●	●	●	●	●	●	●	○	●
AX522	●	○	●	●	●	●	●	●	●	●	●	●	●	○	●
AX522-XC	●	○	●	●	●	●	●	●	●	●	●	●	●	○	●
AX561	●	○	●	●	●	●	●	●	●	●	●	●	●	●	–
CD522	●	○	●	●	●	●	●	●	●	●	●	●	●	○	–
CD522-XC	●	○	●	●	●	●	●	●	●	●	●	●	●	○	–
CI501-PNIO	●	○	●	●	●	●	●	●	●	●	●	●	●	○	○
CI501-PNIO-XC	●	○	●	●	●	●	●	●	●	●	●	●	●	○	○
CI502-PNIO	●	○	●	●	●	●	●	●	●	●	●	●	●	○	○
CI502-PNIO-XC	●	○	●	●	●	●	●	●	●	●	●	●	●	○	○
CI504-PNIO	●	○	●	●	●	●	●	●	●	●	●	●	●	○	○
CI504-PNIO-XC	●	○	●	●	●	●	●	●	●	●	●	●	●	○	○
CI506-PNIO	●	○	●	●	●	●	●	●	●	●	●	●	●	○	○
CI506-PNIO-XC	●	○	●	●	●	●	●	●	●	●	●	●	●	○	○

- Symbols and legends:**
- Standard product certified; product label wears approval mark when mandatory
  - Submitted (roadmap available upon request)
  - Submission planned (roadmap available upon request)
  - Submission not planned or not applicable for product

Name	Conformité Européenne	UKCA UK Conformity Assessed	SJ/T 11363-2006 (China RoHS)	Regulatory Compliance Mark (RCM)	Eurasian Conformity	Korea Certification	Underwriter Laboratories	American Bureau of Shipping	Bureau Veritas	DNV-GL	Lloyds Register	RINA	Russian Maritime Register of Shipping	Korean Register of Shipping	China Classification Society	
Logo / Certification Mark																
Certificate	Declaration of Conformity LVD / EMC	Declaration of Conformity	Declaration of Conformity	Declaration of Conformity	Declaration of Conformity	Declaration of Conformity	cULus Ordinary Locations	cULus Hazardous Locations	Design Assessment	Type Approval	Type Approval	Type Approval	Type Approval	Type Approval	Type Approval	
CI511-ETHCAT	●	○	●	●	●	●	●	●	●	●	●	●	●	●	–	–
CI512-ETHCAT	●	○	●	●	●	●	●	●	●	●	●	●	●	●	–	–
CI521-MODTCP	●	○	●	●	●	○	●	●	●	●	●	●	○	○	●	●
CI521-MODTCP-XC	●	○	●	●	●	○	●	●	●	●	●	●	○	○	●	●
CI522-MODTCP	●	○	●	●	●	○	●	●	●	●	●	●	○	○	●	●
CI522-MODTCP-XC	●	○	●	●	●	○	●	●	●	●	●	●	○	○	●	●
CI541-DP	●	○	●	●	●	●	●	●	●	●	●	●	●	●	○	○
CI541-DP-XC	●	○	●	●	●	●	●	●	●	●	●	●	●	●	○	○
CI542-DP	●	○	●	●	●	●	●	●	●	●	●	●	●	●	○	○
CI542-DP-XC	●	○	●	●	●	●	●	●	●	●	●	●	●	●	○	○
CI581-CN	●	○	●	●	●	●	●	●	●	●	●	●	●	●	○	○
CI581-CN-XC	●	○	●	●	●	●	●	●	●	●	●	●	●	●	○	○
CI582-CN	●	○	●	●	●	●	●	●	●	●	●	●	●	●	○	○
CI582-CN-XC	●	○	●	●	●	●	●	●	●	●	●	●	●	●	○	○
CI590-CS31-HA	●	○	●	●	●	●	●	●	●	●	●	●	●	●	–	●
CI590-CS31-HA-XC	●	○	●	●	●	●	●	●	●	●	●	●	●	●	–	●
CI592-CS31	●	○	●	●	●	●	●	●	●	●	●	●	●	●	–	●
CI592-CS31-XC	●	○	●	●	●	●	●	●	●	●	●	●	●	●	–	●
CM572-DP	●	○	●	●	●	●	●	●	●	●	●	●	●	●	–	–
CM572-DP-XC	●	○	●	●	●	●	●	●	●	●	●	●	●	●	–	–
CM574-RCOM	●	○	●	●	●	●	●	●	●	●	●	●	●	●	–	–
CM574-RS	●	○	●	●	●	●	●	●	●	●	●	●	●	●	○	–
CM578-CN	●	○	●	●	●	●	●	●	●	●	●	●	●	●	–	–
CM578-CN-XC	●	○	●	●	●	●	●	●	●	●	●	●	●	●	–	–
CM579-ETHCAT	●	○	●	●	●	●	●	●	●	●	●	●	●	●	–	–
CM579-PNIO	●	○	●	●	●	●	●	●	●	●	●	●	●	●	○	○
CM579-PNIO-XC	●	○	●	●	●	●	●	●	●	●	●	●	●	●	○	○
CM582-DP	●	○	●	○	●	○	●	●	○	○	○	○	○	○	○	○
CM582-DP-XC	●	○	●	○	●	○	●	●	○	○	○	○	○	○	○	○
CM588-CN	●	○	●	●	●	●	●	●	●	●	●	●	●	●	○	○
CM588-CN-XC	●	○	●	●	●	●	●	●	●	●	●	●	●	●	○	○
CM589-PNIO	●	○	●	○	●	○	●	●	○	●	●	●	○	○	○	○
CM589-PNIO-4	●	○	●	○	●	○	●	●	●	●	●	●	○	○	○	○
CM589-PNIO-4-XC	●	○	●	○	●	○	●	●	●	●	●	●	○	○	○	○
CM589-PNIO-XC	●	○	●	○	●	○	●	●	○	●	●	●	○	○	○	○
CM592-DP	●	○	●	○	●	○	●	●	○	●	●	●	○	○	○	○
CM592-DP-XC	●	○	●	○	●	○	●	●	○	●	●	●	○	○	○	○
CM597-ETH	●	○	●	●	●	○	●	●	○	●	●	●	○	○	○	●
CM597-ETH-XC	●	○	●	●	●	○	●	●	○	●	●	●	○	○	○	●
CM598-CN	●	○	●	○	●	○	●	●	○	●	●	●	○	○	○	○
CM598-CN-XC	●	○	●	○	●	○	●	●	○	●	●	●	○	○	○	○
CP604	●	○	●	○	●	○	●	–	–	–	●	–	–	–	–	–
CP604-B	●	○	●	○	●	○	●	–	–	–	●	–	–	–	–	–
CP607	●	○	●	○	●	○	●	–	–	–	●	–	–	–	–	–
CP607-B	●	○	●	○	●	○	●	–	–	–	●	–	–	–	–	–
CP610	●	○	●	○	●	○	●	–	–	–	●	–	–	–	–	–
CP610-B	●	○	●	○	●	○	●	–	–	–	●	–	–	–	–	–

# Additional information

## Certifications

**Symbols and legends:**

- Standard product certified: product label wears approval mark when mandatory
- Submitted (roadmap available upon request)
- Submission planned (roadmap available upon request)
- Submission not planned or not applicable for product

Name	Conformité Européenne	UKCA UK Conformity Assessed	SJ/T 11363-2006 (China RoHS)	Regulatory Compliance Mark (RCM)	Eurasian Conformity	Korea Certification	Underwriter Laboratories	American Bureau of Shipping	Bureau Veritas	DNV-GL	Lloyds Register	RINA	Russian Maritime Register of Shipping	Korean Register of Shipping	China Classification Society
Logo / Certification Mark															
Certificate	Declaration of Conformity LVD / EMC	Declaration of Conformity	Declaration of Conformity	Declaration of Conformity	Declaration of Conformity	Declaration of Conformity	cULus Ordinary Locations	cULus Hazardous Locations	Design Assessment	Type Approval	Type Approval	Type Approval	Type Approval	Type Approval	Type Approval
CP620	●	○	●	●	●	●	●	●	–	–	●	–	–	–	–
CP620-WEB	●	○	●	●	●	●	●	●	–	–	●	–	–	–	–
CP630	●	○	●	●	●	●	●	●	–	–	●	–	–	–	–
CP630-WEB	●	○	●	●	●	●	●	●	–	–	●	–	–	–	–
CP635	●	○	●	●	●	●	●	●	–	–	●	–	–	–	–
CP635-B	●	○	●	●	●	○	●	●	–	–	●	–	–	–	–
CP635-FB	●	○	●	○	●	○	●	–	–	–	●	–	–	–	–
CP635-FW	●	○	●	○	●	○	●	–	–	–	●	–	–	–	–
CP635-WEB	●	○	●	●	●	●	●	●	–	–	●	–	–	–	–
CP6407	●	○	●	○	○	○	●	●	–	–	●	–	–	○	○
CP6410	●	○	●	○	○	○	●	●	–	–	●	–	–	○	○
CP6415	●	○	●	○	○	○	●	●	–	–	●	–	–	○	○
CP651	●	○	●	○	●	○	●	●	–	–	●	–	–	–	–
CP651-WEB	●	○	●	○	●	○	●	●	–	–	●	–	–	–	–
CP6605	●	○	●	○	●	○	●	●	–	–	●	–	–	○	–
CP6607	●	○	●	○	●	○	●	●	–	–	●	–	–	○	–
CP661	●	○	●	○	●	○	●	●	–	–	●	–	–	–	–
CP6610	●	○	●	○	●	○	●	●	–	–	●	–	–	○	–
CP6615	●	○	●	○	●	○	●	●	–	–	●	–	–	○	–
CP661-WEB	●	○	●	○	●	○	●	●	–	–	●	–	–	–	–
CP6621	●	○	●	○	●	○	●	●	–	–	●	–	–	○	–
CP665	●	○	●	○	●	○	●	●	–	–	●	–	–	–	–
CP665-WEB	●	○	●	○	●	○	●	●	–	–	●	–	–	–	–
CP676	●	○	●	○	●	○	●	●	–	–	●	–	–	–	–
CP676-WEB	●	○	●	○	●	○	●	●	–	–	●	–	–	–	–
DA501	●	○	●	●	●	●	●	●	●	●	●	●	●	○	○
DA501-XC	●	○	●	●	●	●	●	●	●	●	●	●	●	○	○
DA502	●	○	●	○	●	○	●	●	●	○	○	●	○	○	○
DA502-XC	●	○	●	○	●	○	●	●	●	○	○	●	○	○	○
DC522	●	○	●	●	●	●	●	●	●	●	●	●	●	○	●
DC522-XC	●	○	●	●	●	●	●	●	●	●	●	●	●	○	●
DC523	●	○	●	●	●	●	●	●	●	●	●	●	●	○	●
DC523-XC	●	○	●	●	●	●	●	●	●	●	●	●	●	○	●
DC532	●	○	●	●	●	●	●	●	●	●	●	●	●	○	●
DC532-XC	●	○	●	●	●	●	●	●	●	●	●	●	●	○	●
DC541-CM	●	○	●	●	●	●	●	●	●	●	●	●	●	○	–
DC541-CM-XC	●	○	●	●	●	●	●	●	●	●	●	●	●	○	–
DC551-CS31	●	○	●	●	●	●	●	●	●	●	●	●	●	–	●
DC551-CS31-XC	●	○	●	●	●	●	●	●	●	●	●	●	●	–	●

- Symbols and legends:**
- Standard product certified; product label wears approval mark when mandatory
  - Submitted (roadmap available upon request)
  - Submission planned (roadmap available upon request)
  - Submission not planned or not applicable for product

Name	Conformité Européenne	UKCA UK Conformity Assessed	SJ/T 11363-2006 (China RoHS)	Regulatory Compliance Mark (RCM)	Eurasian Conformity	Korea Certification	Underwriter Laboratories	American Bureau of Shipping	Bureau Veritas	DNV-GL	Lloyds Register	RINA	Russian Maritime Register of Shipping	Korean Register of Shipping	China Classification Society	
Logo / Certification Mark																
Certificate	Declaration of Conformity LVD / EMC	Declaration of Conformity	Declaration of Conformity	Declaration of Conformity	Declaration of Conformity	Declaration of Conformity	cULus Ordinary Locations	cULus Hazardous Locations	Design Assessment	Type Approval	Type Approval	Type Approval	Type Approval	Type Approval	Type Approval	
DC561	●	○	●	●	●	●	●	●	●	●	●	●	●	●	●	–
DC562	●	○	●	●	●	○	●	●	●	○	●	●	●	●	●	–
DI524	●	○	●	●	●	●	●	●	●	●	●	●	●	○	●	●
DI524-XC	●	○	●	●	●	●	●	●	●	●	●	●	●	○	●	●
DI561	●	○	●	●	●	●	●	●	●	●	●	●	●	●	●	–
DI562	●	○	●	●	●	●	●	●	●	●	●	●	●	●	●	–
DI571	●	○	●	●	●	●	●	●	●	●	●	●	●	●	●	–
DI572	●	○	●	●	●	○	●	●	●	○	●	●	●	●	●	–
DI581-S	●	○	●	●	●	●	●	●	●	●	●	●	●	○	●	–
DI581-S-XC	●	○	●	●	●	○	●	●	●	●	●	●	●	○	●	–
DO524	●	○	●	○	●	○	●	●	●	●	●	●	○	○	●	●
DO524-XC	●	○	●	○	●	○	●	●	●	●	●	●	○	○	●	●
DO526	●	○	●	○	●	○	●	●	●	●	●	●	○	○	○	○
DO526-XC	●	○	●	○	●	○	●	●	●	●	●	●	○	○	○	○
DO561	●	○	●	●	●	●	●	●	●	●	●	●	●	●	●	–
DO562	●	○	●	●	●	○	●	●	●	○	●	●	●	●	●	–
DO571	●	○	●	●	●	●	●	●	●	●	●	●	●	●	●	–
DO572	●	○	●	●	●	●	●	●	●	●	●	●	●	●	●	–
DO573	●	○	●	●	●	○	●	●	●	○	●	●	●	●	●	–
DX522	●	○	●	●	●	●	●	●	●	●	●	●	●	○	○	○
DX522-XC	●	○	●	●	●	●	●	●	●	●	●	●	●	○	○	○
DX531	●	○	●	●	●	●	●	●	●	●	●	●	●	○	○	○
DX561	●	○	●	●	●	●	●	●	●	●	●	●	●	●	●	–
DX571	●	○	●	●	●	●	●	●	●	●	●	●	●	●	●	–
DX581-S	●	○	●	●	●	●	●	●	●	●	●	●	●	○	○	–
DX581-S-XC	●	○	●	●	●	○	●	●	●	●	●	●	●	○	○	–
FM502-CMS	●	○	●	○	●	●	●	●	●	○	●	●	○	○	○	○
FM502-CMS-XC	●	○	●	○	●	●	●	●	●	○	●	●	○	○	○	○
FM562	●	○	●	●	●	○	●	●	●	○	●	●	○	●	–	–
MC502	●	○	●	–	●	–	●	●	●	●	●	●	●	○	●	●
MC503	●	○	●	●	●	●	●	●	●	●	●	●	●	●	●	–
MC5102	○	○	○	○	○	○	–	–	○	○	○	○	○	○	○	○
MC5141	○	○	○	○	○	○	–	–	○	○	○	○	○	○	○	○
PD501-4CH	●	○	●	●	○	●	●	–	●	●	●	●	●	●	–	–
PM554-RP	●	○	●	●	●	○	●	●	●	●	●	●	●	●	●	–
PM554-RP-AC	●	○	●	●	●	○	●	●	●	●	●	●	●	●	●	–
PM554-TP	●	○	●	●	●	○	●	●	●	●	●	●	●	●	●	–
PM554-TP-ETH	●	○	●	●	●	○	●	●	●	●	●	●	●	●	●	–
PM556-TP-ETH	●	○	●	●	●	○	●	●	●	●	●	●	●	●	●	–
PM5630-2ETH	●	○	●	○	●	○	●	●	●	●	●	●	○	○	●	●
PM5630-2ETH-XC	●	○	●	○	●	○	●	●	●	●	●	●	○	○	●	●
PM564-RP	●	○	●	●	●	○	●	●	●	●	●	●	●	●	●	–
PM564-RP-AC	●	○	●	●	●	○	●	●	●	●	●	●	●	●	●	–
PM564-RP-ETH	●	○	●	●	●	○	●	●	●	●	●	●	●	●	●	–
PM564-RP-ETH-AC	●	○	●	●	●	○	●	●	●	●	●	●	●	●	●	–
PM564-TP	●	○	●	●	●	○	●	●	●	●	●	●	●	●	●	–
PM564-TP-ETH	●	○	●	●	●	○	●	●	●	●	●	●	●	●	●	–

# Additional information

## Certifications

**Symbols and legends:**

- Standard product certified: product label wears approval mark when mandatory
- Submitted (roadmap available upon request)
- Submission planned (roadmap available upon request)
- Submission not planned or not applicable for product

Name	Conformité Européenne	UKCA UK Conformity Assessed	SJ/T 11363-2006 (China RoHS)	Regulatory Compliance Mark (RCM)	Eurasian Conformity	Korea Certification	Underwriter Laboratories	American Bureau of Shipping	Bureau Veritas	DNV-GL	Lloyds Register	RINA	Russian Maritime Register of Shipping	Korean Register of Shipping	China Classification Society
Logo / Certification Mark															
Certificate	Declaration of Conformity LVD / EMC	Declaration of Conformity	Declaration of Conformity	Declaration of Conformity	Declaration of Conformity	Declaration of Conformity	cULus Ordinary Locations	cULus Hazardous Locations	Design Assessment	Type Approval	Type Approval	Type Approval	Type Approval	Type Approval	Type Approval
PM5650-2ETH	●	○	●	○	●	○	●	●	●	●	●	●	○	○	●
PM5650-2ETH-XC	●	○	●	○	●	○	●	●	●	●	●	●	○	○	●
PM566-TP-ETH	●	○	●	●	●	○	●	●	●	○	●	●	●	●	–
PM5670-2ETH	●	○	●	○	●	○	●	●	●	●	●	●	○	○	●
PM5670-2ETH-XC	●	○	●	○	●	○	●	●	●	●	●	●	○	○	●
PM5675-2ETH	●	○	●	○	●	○	●	●	●	●	●	●	○	○	●
PM5675-2ETH-XC	●	○	●	○	●	○	●	●	●	●	●	●	○	○	●
PM572	●	○	●	●	●	●	●	●	●	●	●	●	●	○	●
PM573-ETH	●	○	●	●	●	●	●	●	●	●	●	●	●	○	●
PM573-ETH-XC	●	○	●	●	●	●	●	●	●	●	●	●	●	○	●
PM582	●	○	●	●	●	●	●	●	●	●	●	●	●	○	●
PM582-XC	●	○	●	●	●	●	●	●	●	●	●	●	●	○	●
PM583-ETH	●	○	●	●	●	●	●	●	●	●	●	●	●	○	●
PM583-ETH-XC	●	○	●	●	●	●	●	●	●	●	●	●	●	○	●
PM585-ETH	●	○	●	○	●	○	●	–	●	●	●	●	○	○	●
PM590-ARCNET	●	○	●	●	●	●	●	●	●	●	●	●	●	–	–
PM590-ETH	●	○	●	●	●	●	●	●	●	●	●	●	●	○	●
PM591-2ETH	●	○	●	●	●	○	●	–	●	○	●	●	○	○	●
PM591-ETH	●	○	●	●	●	●	●	●	●	●	●	●	●	○	●
PM591-ETH-XC	●	○	●	●	●	●	●	●	●	●	●	●	●	○	●
PM592-ETH	●	○	●	●	●	●	●	●	●	●	●	●	●	○	●
PM592-ETH-XC	●	○	●	●	●	●	●	●	●	●	●	●	●	○	●
PM595-4ETH-F	●	○	●	○	●	○	●	●	○	●	●	●	○	○	–
PM595-4ETH-M-XC	●	○	●	○	●	○	●	●	○	●	●	●	○	○	–
SM560-S	●	○	●	●	●	●	●	●	●	●	●	●	●	○	–
SM560-S-FD-1	●	○	●	○	●	○	●	●	○	●	●	●	○	○	–
SM560-S-FD-1-XC	●	○	●	○	●	○	●	●	○	●	●	●	○	○	–
SM560-S-FD-4	●	○	●	○	●	○	●	●	○	●	●	●	○	○	–
SM560-S-FD-4-XC	●	○	●	○	●	○	●	●	○	●	●	●	○	○	–
SM560-S-XC	●	○	●	●	●	○	●	●	●	●	●	●	●	○	–
TA521	–	–	●	–	●	–	●	–	●	○	●	–	●	●	○
TA523	●	○	●	–	–	–	●	–	●	–	–	●	●	–	○
TA524	●	○	●	–	●	–	●	–	●	●	–	●	●	○	○
TA525	●	○	●	–	–	–	●	–	●	–	–	●	●	–	–
TA526	●	○	●	–	–	–	●	–	●	○	●	–	●	–	○
TA527	●	○	●	–	●	–	–	–	–	–	–	–	–	–	–
TA528	●	○	●	–	●	–	–	–	–	–	–	–	–	–	–
TA532	●	○	●	–	●	–	–	–	–	–	–	–	–	–	–
TA533	●	○	●	–	●	–	–	–	–	–	–	–	–	–	–



- Symbols and legends:**
- Standard product certified; product label wears approval mark when mandatory
  - Submitted (roadmap available upon request)
  - Submission planned (roadmap available upon request)
  - Submission not planned or not applicable for product

Name	Conformité Européenne	UKCA UK Conformity Assessed	SJ/T 11363-2006 (China RoHS)	Regulatory Compliance Mark (RCM)	Eurasian Conformity	Korea Certification	Underwriter Laboratories	American Bureau of Shipping	Bureau Veritas	DNV-GL	Lloyds Register	RINA	Russian Maritime Register of Shipping	Korean Register of Shipping	China Classification Society
Logo / Certification Mark															
Certificate	Declaration of Conformity LVD / EMC	Declaration of Conformity	Declaration of Conformity	Declaration of Conformity	Declaration of Conformity	Declaration of Conformity	cULus Ordinary Locations	cULus Hazardous Locations	Design Assessment	Type Approval	Type Approval	Type Approval	Type Approval	Type Approval	Type Approval
TA534	●	○	●	–	●	–	–	–	–	–	–	–	–	–	–
TA535	●	○	●	–	–	–	–	–	–	–	–	–	–	–	–
TA536	●	○	●	–	●	–	–	–	–	–	–	–	–	–	–
TA540	●	○	●	–	–	–	–	–	–	–	–	–	–	–	–
TA541	–	–	●	–	●	–	–	–	–	–	–	–	–	○	–
TA543	●	○	●	–	–	–	–	–	–	–	–	–	–	–	–
TA561-RTC	●	○	●	●	●	●	●	●	●	●	●	●	●	●	–
TA562-RS	●	○	●	●	●	●	●	●	●	●	●	●	●	●	–
TA562-RS-RTC	●	○	●	●	●	●	●	●	●	●	●	●	●	●	–
TA563-11	●	○	●	–	●	–	–	–	●	●	●	●	●	●	–
TA563-9	●	○	●	–	●	–	–	–	●	●	●	●	●	●	–
TA564-11	●	○	●	–	●	–	–	–	●	●	●	●	●	●	–
TA564-9	●	○	●	–	●	–	–	–	●	●	●	●	●	●	–
TA565-11	●	○	●	–	●	–	–	–	●	●	●	●	●	●	–
TA565-9	●	○	●	–	●	–	–	–	●	●	●	●	●	●	–
TA566	●	○	●	–	–	–	●	●	●	●	●	●	●	●	–
TA569-RS-ISO	●	○	●	○	○	○	●	●	○	●	●	●	●	○	–
TA570	●	○	●	–	●	–	●	●	–	–	–	–	–	●	–
TA571-SIM	●	○	●	●	●	●	–	–	–	–	–	–	–	●	–
TB511-ARCNET	●	○	●	●	●	●	●	●	●	●	●	●	●	–	–
TB511-ETH	●	○	●	●	●	●	●	●	●	●	●	●	●	○	●
TB511-ETH-XC	●	○	●	●	●	●	●	●	●	●	●	●	●	○	●
TB521-ARCNET	●	○	●	●	●	●	●	●	●	●	●	●	●	–	–
TB521-ETH	●	○	●	●	●	●	●	●	●	●	●	●	●	○	●
TB521-ETH-XC	●	○	●	●	●	●	●	●	●	●	●	●	●	○	●
TB523-2ETH	●	○	●	●	●	○	–	●	○	●	●	●	○	○	●
TB541-ETH	●	○	●	●	●	○	●	●	●	●	●	●	●	○	●
TB541-ETH-XC	●	○	●	●	●	○	●	●	●	●	●	●	●	○	●
TB5600-2ETH	●	○	●	○	●	○	●	●	●	●	●	●	○	○	●
TB5600-2ETH-XC	●	○	●	○	●	○	●	●	●	●	●	●	○	○	●
TB5610-2ETH	●	○	●	○	●	○	●	●	●	●	●	●	○	○	●
TB5610-2ETH-XC	●	○	●	○	●	○	●	●	●	●	●	●	○	○	●
TB5620-2ETH	●	○	●	○	●	○	●	●	●	●	●	●	○	○	●
TB5620-2ETH-XC	●	○	●	○	●	○	●	●	●	●	●	●	○	○	●
TB5640-2ETH	●	○	●	○	●	○	●	●	○	○	●	○	○	○	●
TB5640-2ETH-XC	●	○	●	○	●	○	●	●	○	○	●	○	○	○	●
TB5660-2ETH	●	○	●	○	●	○	●	●	○	○	●	○	○	○	●
TB5660-2ETH-XC	●	○	●	○	●	○	●	●	○	○	●	○	○	○	●
TF501-CMS	●	○	●	○	●	○	●	●	●	○	●	●	○	○	○
TF501-CMS-XC	●	○	●	○	●	○	●	●	●	○	●	●	○	○	○
TF521-CMS	●	○	●	○	●	○	●	●	●	○	●	●	○	○	○
TF521-CMS-XC	●	○	●	○	●	○	●	●	●	○	●	●	○	○	○
TK501	●	○	●	–	●	–	●	●	●	–	–	–	●	●	–
TK502	●	○	●	–	●	–	●	●	●	–	–	–	●	●	–
TK503	●	○	●	●	●	●	●	●	●	●	○	●	●	●	–
TK504	●	○	●	●	●	●	●	●	●	●	●	●	●	●	–
TK506	●	○	●	●	●	○	●	●	●	●	●	●	●	●	–

# Additional information

## Certifications

**Symbols and legends:**

- Standard product certified: product label wears approval mark when mandatory
- ◐ Submitted (roadmap available upon request)
- Submission planned (roadmap available upon request)
- Submission not planned or not applicable for product

Name	Conformité Européenne	UKCA UK Conformity Assessed	SJ/T 11363-2006 (China RoHS)	Regulatory Compliance Mark (RCM)	Eurasian Conformity	Korea Certification	Underwriter Laboratories	American Bureau of Shipping	Bureau Veritas	DNV-GL	Lloyds Register	RINA	Russian Maritime Register of Shipping	Korean Register of Shipping	China Classification Society
Logo / Certification Mark															
Certificate	Declaration of Conformity LVD / EMC	Declaration of Conformity	Declaration of Conformity	Declaration of Conformity	Declaration of Conformity	Declaration of Conformity	cULus Ordinary Locations	cULus Hazardous Locations	Design Assessment	Type Approval	Type Approval	Type Approval	Type Approval	Type Approval	Type Approval
TU507-ETH	●	○	●	●	●	●	●	●	●	●	●	●	●	○	●
TU508-ETH	●	○	●	●	●	●	●	●	●	●	●	●	●	○	●
TU508-ETH-XC	●	○	●	●	●	●	●	●	●	●	●	●	●	○	●
TU509	●	○	●	●	●	●	●	●	●	●	●	●	●	○	○
TU510	●	○	●	●	●	●	●	●	●	●	●	●	●	○	○
TU510-XC	●	○	●	●	●	●	●	●	●	●	●	●	●	○	○
TU515	●	○	●	●	●	●	●	●	●	●	●	●	●	○	●
TU516	●	○	●	●	●	●	●	●	●	●	●	●	●	○	●
TU516-H	●	○	●	○	●	○	●	●	○	○	○	○	○	–	○
TU516-H-XC	●	○	●	○	●	○	●	●	○	○	○	○	○	–	○
TU516-XC	●	○	●	●	●	●	●	●	●	●	●	●	●	○	●
TU517	●	○	●	●	●	●	●	●	●	●	●	●	●	○	○
TU518	●	○	●	●	●	●	●	●	●	●	●	●	●	○	○
TU518-XC	●	○	●	●	●	●	●	●	●	●	●	●	●	○	○
TU520-ETH	●	○	●	●	●	●	●	●	●	●	●	●	●	○	○
TU520-ETH-XC	●	○	●	●	●	●	●	●	●	●	●	●	●	○	○
TU531	●	○	●	●	●	●	●	●	●	●	●	●	●	○	○
TU532	●	○	●	●	●	●	●	●	●	●	●	●	●	○	○
TU532-H	●	○	●	○	●	○	●	●	○	○	○	○	○	○	○
TU532-H-XC	●	○	●	○	●	○	●	●	○	○	○	○	○	○	○
TU532-XC	●	○	●	●	●	●	●	●	●	●	●	●	●	○	○
TU541	●	○	●	○	●	○	●	–	●	●	●	●	●	○	○
TU542	●	○	●	●	●	●	●	–	●	●	●	●	●	○	○
TU542-H	●	○	●	○	●	○	●	●	○	○	○	○	○	○	○
TU542-H-XC	●	○	●	○	●	○	●	●	○	○	○	○	○	○	○
TU542-XC	●	○	●	○	●	○	●	–	●	●	●	●	●	○	○
TU551-CS31	●	○	●	●	●	●	●	●	●	●	●	●	●	–	●
TU552-CS31	●	○	●	●	●	●	●	●	●	●	●	●	●	–	●
TU552-CS31-XC	●	○	●	●	●	●	●	●	●	●	●	●	●	–	●
TU582-S	●	○	●	●	●	○	●	●	●	●	●	●	●	○	–
TU582-S-XC	●	○	●	●	●	○	●	●	●	●	●	●	●	○	–



## Index

### Order code classification

Order code	Type	Page
1SAP110300R0278	TB5600-2ETH	109
1SAP111100R0260	TB511-ARCNET	106
1SAP111100R0270	TB511-ETH	106
1SAP111300R0278	TB5610-2ETH	109
1SAP112100R0260	TB521-ARCNET	106
1SAP112100R0270	TB521-ETH	106
1SAP112300R0277	TB523-2ETH	106
1SAP112300R0278	TB5620-2ETH	109
1SAP114100R0270	TB541-ETH	106
1SAP114300R0278	TB5640-2ETH	109
1SAP116300R0278	TB5660-2ETH	109
1SAP117000R0271	TF501-CMS	107
1SAP117200R0271	TF521-CMS	107
1SAP120600R0001	PM554-TP	74
1SAP120600R0071	PM554-TP-ETH	74
1SAP120700R0001	PM554-RP	74
1SAP120800R0001	PM554-RP-AC	74
1SAP120900R0001	PM564-TP	74
1SAP120900R0071	PM564-TP-ETH	74
1SAP121000R0001	PM564-RP	74
1SAP121000R0071	PM564-RP-ETH	74
1SAP121100R0001	PM564-RP-AC	74
1SAP121100R0071	PM564-RP-ETH-AC	74
1SAP121200R0071	PM556-TP-ETH	74
1SAP121500R0071	PM566-TP-ETH	74
1SAP122600R0072	PM5012-T-ETH	76
1SAP122700R0072	PM5012-R-ETH	76
1SAP123400R0072	PM5032-T-ETH	76
1SAP123500R0072	PM5032-R-ETH	76
1SAP124000R0072	PM5052-T-ETH	76
1SAP124100R0072	PM5052-R-ETH	76
1SAP124400R0073	PM5072-T-2ETHW	76
1SAP124500R0073	PM5072-T-2ETH	76
1SAP130200R0200	PM572	104
1SAP130300R0271	PM573-ETH	104
1SAP131000R0278	PM5630-2ETH	108
1SAP131000R0278	PM5630-2ETH	245
1SAP140200R0201	PM582	104
1SAP140300R0271	PM583-ETH	104
1SAP140500R0271	PM585-ETH	104
1SAP140500R0379	PM585-MC-KIT	104
1SAP140500R0379	PM585-MC-KIT	245
1SAP141000R0278	PM5650-2ETH	108
1SAP141000R0278	PM5650-2ETH	245
1SAP150000R0261	PM590-ARCNET	104
1SAP150000R0271	PM590-ETH	104
1SAP150000R0379	PM590-MC-KIT	104
1SAP150000R0379	PM590-MC-KIT	245
1SAP150100R0271	PM591-ETH	104
1SAP150100R0277	PM591-2ETH	104
1SAP150200R0271	PM592-ETH	104
1SAP151000R0278	PM5670-2ETH	108
1SAP151000R0278	PM5670-2ETH	245
1SAP151500R0278	PM5675-2ETH	108
1SAP155500R0279	PM595-4ETH-F	245
1SAP155500R0279	PM595-4ETH-F	105
1SAP170400R0201	CM574-RS	110

Order code	Type	Page
1SAP170401R0201	CM574-RCOM	110
1SAP170901R0101	CM579-PNIO	110
1SAP170902R0101	CM579-ETHCAT	110
1SAP172200R0001	CM582-DP	110
1SAP172800R0001	CM588-CN	110
1SAP172900R0011	CM589-PNIO	110
1SAP172900R0111	CM589-PNIO-4	110
1SAP173200R0001	CM592-DP	110
1SAP173700R0001	CM597-ETH	110
1SAP173800R0001	CM598-CN	110
1SAP180100R0001	MC502	117
1SAP180100R0001	MC502	165
1SAP180100R0001	MC502	75
1SAP180100R0002	MC5102	77
1SAP180100R0002	MC5102	117
1SAP180100R0002	MC5102	75
1SAP180100R0041	MC5141	117
1SAP180100R0041	MC5141	165
1SAP180300R0001	TA521	117
1SAP180300R0001	TA521	165
1SAP180500R0001	TA523	117
1SAP180500R0001	TA523	165
1SAP180600R0001	TA524	117
1SAP180600R0001	TA524	165
1SAP180700R0001	TA525	117
1SAP180700R0001	TA525	165
1SAP180800R0001	TA526	117
1SAP180800R0001	TA526	165
1SAP181100R0001	TA527	117
1SAP181100R0001	TA527	165
1SAP181200R0001	TA528	117
1SAP181200R0001	TA528	165
1SAP181400R0001	TA561-RTC	75
1SAP181500R0001	TA562-RS-RTC	75
1SAP182000R0001	TA532	117
1SAP182000R0001	TA532	165
1SAP182100R0001	TA533	117
1SAP182100R0001	TA533	165
1SAP182200R0001	TA534	117
1SAP182200R0001	TA534	165
1SAP182300R0001	TA535	165
1SAP182400R0002	TA515-CASE	117
1SAP182400R0002	TA515-CASE	258
1SAP182600R0001	TA540	117
1SAP182600R0001	TA540	165
1SAP182700R0001	TA541	117
1SAP182700R0001	TA541	165
1SAP182800R0001	TA543	77
1SAP182800R0001	TA543	117
1SAP182800R0001	TA543	165
1SAP182900R0001	TA514-SAFETY	200
1SAP182900R0001	TA514-SAFETY	258
1SAP183100R0001	TA536	117
1SAP183100R0001	TA536	165
1SAP186100R0001	TK506	75
1SAP186200R0004	TA574-D-T-ETH	259
1SAP186400R0001	TA569-RS-ISO	75

Order code	Type	Page
1SAP187000R0001	TA5101-4DI	78
1SAP187000R0002	TA5105-4DOT	78
1SAP187000R0003	TA5110-2DI2DOT	78
1SAP187100R0001	TA5120-2AI-UI	78
1SAP187100R0002	TA5123-2AI-RTD	78
1SAP187100R0003	TA5126-2AO-UI	78
1SAP187100R0004	TA5122-2AI-TC	78
1SAP187200R0001	TA5130-KNXPB	79
1SAP187200R0002	TA5131-RTC	77
1SAP187200R0002	TA5131-RTC	79
1SAP187300R0001	TA5141-RS232I	79
1SAP187300R0002	TA5142-RS485I	79
1SAP187300R0003	TA5142-RS485	79
1SAP187400R0001	TA5211-TSCL-B	77
1SAP187400R0002	TA5211-TSPF-B	77
1SAP187400R0004	TA5212-TSCL	77
1SAP187400R0005	TA5212-TSPF	77
1SAP187400R0012	TA5220-SPF5	79
1SAP187400R0013	TA5220-SPF6	79
1SAP187400R0014	TA5220-SPF7	79
1SAP187400R0015	TA5220-SPF8	79
1SAP187400R0016	TA5220-SPF9	79
1SAP187500R0001	TA5300-CVR	77
1SAP187500R0003	TA5301-CFA	77
1SAP187600R0001	TA5400-SIM	77
1SAP187600R0002	TA5415-STAKIT	259
1SAP187600R0003	TA5426-STAKIT	259
1SAP187700R0001	TA5450-CASE	117
1SAP187700R0001	TA5450-CASE	258
1SAP192100R0102	PS552-MC-E	61
1SAP192150R0101	PS5611-MC	61
1SAP192150R0101	PS5611-MC	108
1SAP192150R0101	PS5611-MC	157
1SAP193600R0001	DM-KEY	60
1SAP195000R0101	PS562-SOLAR	61
1SAP195400R0101	PS5601-HA-MTCP	61
1SAP195400R0101	PS5601-HA-MTCP	108
1SAP195400R0101	PS5601-HA-MTCP	157
1SAP195500R0101	PS565-BACnet-ASC	61
1SAP195550R0101	PS5607-BACnet-BC	108
1SAP195550R0101	PS5607-BACnet-BC	157
1SAP195550R0101	PS5607-BACnet-BC	61
1SAP195600R0101	PS5602-61850	61
1SAP195600R0101	PS5602-61850	108
1SAP195600R0101	PS5602-61850	157
1SAP195800R0101	PS5604-KNX	61
1SAP195800R0101	PS5604-KNX	108
1SAP195800R0101	PS5604-KNX	157
1SAP196100R0101	PS5613-EIP-A	61
1SAP196100R0101	PS5613-EIP-A	108
1SAP196100R0101	PS5613-EIP-A	157
1SAP196101R0101	PS5613-EIP-S	61
1SAP196101R0101	PS5613-EIP-S	108
1SAP196101R0101	PS5613-EIP-S	157
1SAP196102R0101	PS5613-EIP-A-e	61
1SAP196103R0101	PS5613-EIP-S-e	61
1SAP210400R0001	TU552-CS31	115

## Index

### Order code classification

Order code	Type	Page	Order code	Type	Page	Order code	Type	Page
1SAP210600R0001	TU551-CS31	115	1SAP281200R0001	TU582-S	200	1SAP424100R0001	CI541-DP-XC	162
1SAP210800R0001	TU510	115	1SAP282000R0001	AI581-S	200	1SAP424200R0001	CI542-DP-XC	162
1SAP211000R0001	TU509	115	1SAP284000R0001	DI581-S	200	1SAP428100R0001	CI581-CN-XC	162
1SAP211200R0001	TU518	115	1SAP284100R0001	DX581-S	200	1SAP428200R0001	CI582-CN-XC	162
1SAP211400R0001	TU517	115	1SAP286000R0001	SM560-S-FD-1	200	1SAP440000R0001	DI524-XC	160
1SAP212000R0001	TU516	115	1SAP286100R0001	SM560-S-FD-4	200	1SAP440100R0001	DC532-XC	160
1SAP212200R0001	TU515	115	1SAP310300R0278	TB5600-2ETH-XC	158	1SAP440500R0001	DC523-XC	160
1SAP213000R0001	TU541	115	1SAP311100R0270	TB511-ETH-XC	155	1SAP440600R0001	DC522-XC	160
1SAP213200R0001	TU542	115	1SAP311300R0278	TB5610-2ETH-XC	158	1SAP440700R0001	DO524-XC	160
1SAP214000R0001	TU508-ETH	115	1SAP312100R0270	TB521-ETH-XC	155	1SAP440800R0001	DO526-XC	160
1SAP214200R0001	TU507-ETH	115	1SAP312300R0278	TB5620-2ETH-XC	158	1SAP445200R0001	DX522-XC	160
1SAP214400R0001	TU520-ETH	115	1SAP314100R0270	TB541-ETH-XC	155	1SAP450000R0001	AX522-XC	161
1SAP215000R0001	TU516-H	114	1SAP314300R0278	TB5640-2ETH-XC	158	1SAP450100R0001	AX521-XC	161
1SAP215100R0001	TU532-H	114	1SAP316300R0278	TB5660-2ETH-XC	158	1SAP450200R0001	AO523-XC	161
1SAP215200R0001	TU542-H	114	1SAP317000R0271	TF501-CMS-XC	156	1SAP450300R0001	AI523-XC	161
1SAP217000R0001	TU532	115	1SAP317200R0271	TF521-CMS-XC	156	1SAP450500R0001	AC522-XC	161
1SAP217200R0001	TU531	115	1SAP330300R0271	PM573-ETH-XC	154	1SAP450600R0001	AI531-XC	161
1SAP220500R0001	DC551-CS31	113	1SAP331000R0278	PM5630-2ETH-XC	157	1SAP450700R0001	DA501-XC	161
1SAP220600R0001	CI501-PNIO	113	1SAP340200R0201	PM582-XC	154	1SAP450800R0001	DA502-XC	161
1SAP220700R0001	CI502-PNIO	113	1SAP340300R0271	PM583-ETH-XC	154	1SAP460300R0001	CD522-XC	161
1SAP220900R0001	CI511-ETHCAT	113	1SAP341000R0278	PM5650-2ETH-XC	157	1SAP460400R0001	FM502-CMS-XC	156
1SAP221000R0001	CI512-ETHCAT	113	1SAP350100R0271	PM591-ETH-XC	154	1SAP470000R0001	DC541-CM-XC	161
1SAP221100R0001	CI590-CS31-HA	113	1SAP350200R0271	PM592-ETH-XC	154	1SAP481200R0001	TU582-S-XC	201
1SAP221200R0001	CI592-CS31	113	1SAP351000R0278	PM5670-2ETH-XC	157	1SAP482000R0001	AI581-S-XC	201
1SAP221300R0001	CI504-PNIO	114	1SAP351500R0278	PM5675-2ETH-XC	157	1SAP484000R0001	DI581-S-XC	201
1SAP221500R0001	CI506-PNIO	114	1SAP351500R0279	PM595-4ETH-M-XC	154	1SAP484100R0001	DX581-S-XC	201
1SAP222100R0001	CI521-MODTCP	113	1SAP370901R0101	CM579-PNIO-XC	159	1SAP500900R0101	PB610	216
1SAP222200R0001	CI522-MODTCP	113	1SAP372200R0001	CM582-DP-XC	159	1SAP500901R0101	PB610-R	216
1SAP224100R0001	CI541-DP	113	1SAP372800R0001	CM588-CN-XC	159	1SAP500981R0001	TK681	216
1SAP224200R0001	CI542-DP	113	1SAP372900R0011	CM589-PNIO-XC	159	1SAP500982R0001	TK682	216
1SAP228100R0001	CI581-CN	113	1SAP372900R0111	CM589-PNIO-4-XC	159	1SAP504100R0001	CP604	214
1SAP228200R0001	CI582-CN	113	1SAP373200R0001	CM592-DP-XC	159	1SAP504100R2001	CP604-B	214
1SAP230500R0000	DI572	80	1SAP373700R0001	CM597-ETH-XC	159	1SAP507100R0001	CP607	214
1SAP230900R0000	DO562	80	1SAP373800R0001	CM598-CN-XC	159	1SAP507100R2001	CP607-B	214
1SAP231300R0000	DO573	80	1SAP380000R0001	SM560-S-XC	201	1SAP510100R0001	CP610	214
1SAP231900R0000	DC562	80	1SAP386000R0001	SM560-S-FD-1-XC	201	1SAP510100R2001	CP610-B	214
1SAP233100R0001	FM562	81	1SAP386100R0001	SM560-S-FD-4-XC	201	1SAP540710R0001	CP6407	214
1SAP240000R0001	DI524	111	1SAP410400R0001	TU552-CS31-XC	163	1SAP541010R0001	CP6410	214
1SAP240100R0001	DC532	111	1SAP410800R0001	TU510-XC	163	1SAP541510R0001	CP6415	214
1SAP240500R0001	DC523	111	1SAP411200R0001	TU518-XC	163	1SAP560510R0001	CP6605	215
1SAP240600R0001	DC522	111	1SAP412000R0001	TU516-XC	163	1SAP560710R0001	CP6607	215
1SAP240700R0001	DO524	111	1SAP413200R0001	TU542-XC	163	1SAP561010R0001	CP6610	215
1SAP240800R0001	DO526	111	1SAP414000R0001	TU508-ETH-XC	163	1SAP561510R0001	CP6615	215
1SAP245000R0001	DX531	111	1SAP414400R0001	TU520-ETH-XC	163	1SAP562110R0001	CP6621	215
1SAP245200R0001	DX522	111	1SAP415000R0001	TU516-H-XC	163	1SAS010000R0102	DM200-TOOL	60
1SAP250000R0001	AX522	112	1SAP415100R0001	TU532-H-XC	163	1SAS010001R0102	DM201-TOOL-UPGR	60
1SAP250100R0001	AX521	112	1SAP415200R0001	TU542-H-XC	163	1SAS010002R0102	DM202-PREM	60
1SAP250200R0001	AO523	112	1SAP417000R0001	TU532-XC	163	1SAS010003R0102	DM203-PREM-UPGR	60
1SAP250300R0001	AI523	112	1SAP420500R0001	DC551-CS31-XC	162	1SAS010004R0102	DM204-TOOL-NW	60
1SAP250500R0001	AC522	112	1SAP420600R0001	CI501-PNIO-XC	162	1SAS010007R0102	DM207-PVC	60
1SAP250600R0001	AI531	112	1SAP420700R0001	CI502-PNIO-XC	162	1SAS010010R0102	DM210-PSA	60
1SAP250700R0001	DA501	112	1SAP421100R0001	CI590-CS31-HA-XC	162	1SAS010011R0102	DM211-PPR	60
1SAP250800R0001	DA502	112	1SAP421200R0001	CI592-CS31-XC	162	1SAS010014R0102	DM214-PVC-NW	60
1SAP260300R0001	CD522	112	1SAP421300R0001	CI504-PNIO-XC	162	1SAS010017R0102	DM217-PSA-NW	60
1SAP260400R0001	FM502-CMS	107	1SAP421500R0001	CI506-PNIO-XC	162	1SAS010018R0102	DM218-PPR-NW	60
1SAP270000R0001	DC541-CM	112	1SAP422100R0001	CI521-MODTCP-XC	162	1SAS010020R0102	DM220-FSE	60
1SAP280000R0001	SM560-S	200	1SAP422200R0001	CI522-MODTCP-XC	162	1SAS010021R0102	DM221-FSE-NW	60

## Index

### Order code classification

Order code	Type	Page
1SAS010050R0102	DM250-VCP	60
1SAS010051R0102	DM251-VCP-NW	60
1SAS030000R0101	PS563-WATER	61
1SAS030010R0101	PS564-TEMPCTRL	61
1TNE968901R0100	MC503	75
1TNE968901R1100	TK503	75
1TNE968901R2100	TK504	75
1TNE968901R3101	TA563-9	81
1TNE968901R3102	TA563-11	81
1TNE968901R3103	TA564-9	81
1TNE968901R3104	TA564-11	81
1TNE968901R3105	TA565-9	81
1TNE968901R3106	TA565-11	81
1TNE968901R3107	TA566	75
1TNE968901R3203	TA570	75
1TNE968901R4300	TA562-RS	75
1TNE968902R1101	AI561	80
1TNE968902R1102	AI562	80
1TNE968902R1103	AI563	80
1TNE968902R1201	AO561	80
1TNE968902R1301	AX561	80
1TNE968902R2101	DI561	80
1TNE968902R2102	DI562	80
1TNE968902R2103	DI571	80
1TNE968902R2201	DO561	80
1TNE968902R2202	DO571	80
1TNE968902R2203	DO572	80
1TNE968902R2301	DX561	80
1TNE968902R2302	DX571	80
1TNE968903R0203	TA571-SIM	75





# Index

## Type classification

Type	Order code	Page	Type	Order code	Page	Type	Order code	Page
AC522	1SAP250500R0001	112	CM589-PNIO-4	1SAP172900R0111	110	DM220-FSE	1SAS010020R0102	60
AC522-XC	1SAP450500R0001	161	CM589-PNIO-4-XC	1SAP372900R0111	159	DM221-FSE-NW	1SAS010021R0102	60
AI523	1SAP250300R0001	112	CM589-PNIO-XC	1SAP372900R0011	159	DM250-VCP	1SAS010050R0102	60
AI523-XC	1SAP450300R0001	161	CM592-DP	1SAP173200R0001	110	DM251-VCP-NW	1SAS010051R0102	60
AI531	1SAP250600R0001	112	CM592-DP-XC	1SAP373200R0001	159	DM-KEY	1SAP193600R0001	60
AI531-XC	1SAP450600R0001	161	CM597-ETH	1SAP173700R0001	110	DO524	1SAP240700R0001	111
AI561	1TNE968902R1101	80	CM597-ETH-XC	1SAP373700R0001	159	DO524-XC	1SAP440700R0001	160
AI562	1TNE968902R1102	80	CM598-CN	1SAP173800R0001	110	DO526	1SAP240800R0001	111
AI563	1TNE968902R1103	80	CM598-CN-XC	1SAP373800R0001	159	DO526-XC	1SAP440800R0001	160
AI581-S	1SAP282000R0001	200	CP604	1SAP504100R0001	214	DO561	1TNE968902R2201	80
AI581-S-XC	1SAP482000R0001	201	CP604-B	1SAP504100R2001	214	DO562	1SAP230900R0000	80
AO523	1SAP250200R0001	112	CP607	1SAP507100R0001	214	DO571	1TNE968902R2202	80
AO523-XC	1SAP450200R0001	161	CP607-B	1SAP507100R2001	214	DO572	1TNE968902R2203	80
AO561	1TNE968902R1201	80	CP610	1SAP510100R0001	214	DO573	1SAP231300R0000	80
AX521	1SAP250100R0001	112	CP610-B	1SAP510100R2001	214	DX522	1SAP245200R0001	111
AX521-XC	1SAP450100R0001	161	CP6407	1SAP540710R0001	214	DX522-XC	1SAP445200R0001	160
AX522	1SAP250000R0001	112	CP6410	1SAP541010R0001	214	DX531	1SAP245000R0001	111
AX522-XC	1SAP450000R0001	161	CP6415	1SAP541510R0001	214	DX561	1TNE968902R2301	80
AX561	1TNE968902R1301	80	CP6605	1SAP560510R0001	215	DX571	1TNE968902R2302	80
CD522	1SAP260300R0001	112	CP6607	1SAP560710R0001	215	DX581-S	1SAP284100R0001	200
CD522-XC	1SAP460300R0001	161	CP6610	1SAP561010R0001	215	DX581-S-XC	1SAP484100R0001	201
CI501-PNIO	1SAP220600R0001	113	CP6615	1SAP561510R0001	215	FM502-CMS	1SAP260400R0001	107
CI501-PNIO-XC	1SAP420600R0001	162	CP6621	1SAP562110R0001	215	FM502-CMS-XC	1SAP460400R0001	156
CI502-PNIO	1SAP220700R0001	113	DA501	1SAP250700R0001	112	FM562	1SAP23100R0001	81
CI502-PNIO-XC	1SAP420700R0001	162	DA501-XC	1SAP450700R0001	161	MC502	1SAP180100R0001	117
CI504-PNIO	1SAP221300R0001	114	DA502	1SAP250800R0001	112	MC502	1SAP180100R0001	165
CI504-PNIO-XC	1SAP421300R0001	162	DA502-XC	1SAP450800R0001	161	MC502	1SAP180100R0001	75
CI506-PNIO	1SAP221500R0001	114	DC522	1SAP240600R0001	111	MC503	1TNE968901R0100	75
CI506-PNIO-XC	1SAP421500R0001	162	DC522-XC	1SAP440600R0001	160	MC5102	1SAP180100R0002	77
CI511-ETHCAT	1SAP220900R0001	113	DC523	1SAP240500R0001	111	MC5102	1SAP180100R0002	117
CI512-ETHCAT	1SAP221000R0001	113	DC523-XC	1SAP440500R0001	160	MC5102	1SAP180100R0002	75
CI521-MODTCP	1SAP222100R0001	113	DC532	1SAP240100R0001	111	MC5141	1SAP180100R0041	117
CI521-MODTCP-XC	1SAP422100R0001	162	DC532-XC	1SAP440100R0001	160	MC5141	1SAP180100R0041	165
CI522-MODTCP	1SAP222200R0001	113	DC541-CM	1SAP270000R0001	112	PB610	1SAP500900R0101	216
CI522-MODTCP-XC	1SAP422200R0001	162	DC541-CM-XC	1SAP470000R0001	161	PB610-R	1SAP500901R0101	216
CI541-DP	1SAP224100R0001	113	DC551-CS31	1SAP220500R0001	113	PM5012-R-ETH	1SAP122700R0072	76
CI541-DP-XC	1SAP424100R0001	162	DC551-CS31-XC	1SAP420500R0001	162	PM5012-T-ETH	1SAP122600R0072	76
CI542-DP	1SAP224200R0001	113	DC562	1SAP231900R0000	80	PM5032-R-ETH	1SAP123500R0072	76
CI542-DP-XC	1SAP424200R0001	162	DI524	1SAP240000R0001	111	PM5032-T-ETH	1SAP123400R0072	76
CI581-CN	1SAP228100R0001	113	DI524-XC	1SAP440000R0001	160	PM5052-R-ETH	1SAP124100R0072	76
CI581-CN-XC	1SAP428100R0001	162	DI561	1TNE968902R2101	80	PM5052-T-ETH	1SAP124000R0072	76
CI582-CN	1SAP228200R0001	113	DI562	1TNE968902R2102	80	PM5072-T-2ETH	1SAP124500R0073	76
CI582-CN-XC	1SAP428200R0001	162	DI571	1TNE968902R2103	80	PM5072-T-2ETHW	1SAP124400R0073	76
CI590-CS31-HA	1SAP221100R0001	113	DI572	1SAP230500R0000	80	PM554-RP	1SAP120700R0001	74
CI590-CS31-HA-XC	1SAP421100R0001	162	DI581-S	1SAP284000R0001	200	PM554-RP-AC	1SAP120800R0001	74
CI592-CS31	1SAP221200R0001	113	DI581-S-XC	1SAP484000R0001	201	PM554-TP	1SAP120600R0001	74
CI592-CS31-XC	1SAP421200R0001	162	DM200-TOOL	1SAS010000R0102	60	PM554-TP-ETH	1SAP120600R0071	74
CM574-RCOM	1SAP170401R0201	110	DM201-TOOL-UPGR	1SAS010001R0102	60	PM556-TP-ETH	1SAP121200R0071	74
CM574-RS	1SAP170400R0201	110	DM202-PREM	1SAS010002R0102	60	PM5630-2ETH	1SAP131000R0278	108
CM579-ETHCAT	1SAP170902R0101	110	DM203-PREM-UPGR	1SAS010003R0102	60	PM5630-2ETH	1SAP131000R0278	245
CM579-PNIO	1SAP170901R0101	110	DM204-TOOL-NW	1SAS010004R0102	60	PM5630-2ETH-XC	1SAP331000R0278	157
CM579-PNIO-XC	1SAP370901R0101	159	DM207-PVC	1SAS010007R0102	60	PM564-RP	1SAP121000R0001	74
CM582-DP	1SAP172200R0001	110	DM210-PSA	1SAS010010R0102	60	PM564-RP-AC	1SAP121100R0001	74
CM582-DP-XC	1SAP372200R0001	159	DM211-PPR	1SAS010011R0102	60	PM564-RP-ETH	1SAP121000R0071	74
CM588-CN	1SAP172800R0001	110	DM214-PVC-NW	1SAS010014R0102	60	PM564-RP-ETH-AC	1SAP121100R0071	74
CM588-CN-XC	1SAP372800R0001	159	DM217-PSA-NW	1SAS010017R0102	60	PM564-TP	1SAP120900R0001	74
CM589-PNIO	1SAP172900R0011	110	DM218-PPR-NW	1SAS010018R0102	60	PM564-TP-ETH	1SAP120900R0071	74

# Index

## Type classification

Type	Order code	Page
PM5650-2ETH	1SAP141000R0278	108
PM5650-2ETH	1SAP141000R0278	245
PM5650-2ETH-XC	1SAP341000R0278	157
PM566-TP-ETH	1SAP121500R0071	74
PM5670-2ETH	1SAP151000R0278	108
PM5670-2ETH	1SAP151000R0278	245
PM5670-2ETH-XC	1SAP351000R0278	157
PM5675-2ETH	1SAP151500R0278	108
PM5675-2ETH-XC	1SAP351500R0278	157
PM572	1SAP130200R0200	104
PM573-ETH	1SAP130300R0271	104
PM573-ETH-XC	1SAP330300R0271	154
PM582	1SAP140200R0201	104
PM582-XC	1SAP340200R0201	154
PM583-ETH	1SAP140300R0271	104
PM583-ETH-XC	1SAP340300R0271	154
PM585-ETH	1SAP140500R0271	104
PM585-MC-KIT	1SAP140500R0379	104
PM585-MC-KIT	1SAP140500R0379	245
PM590-ARCNET	1SAP150000R0261	104
PM590-ETH	1SAP150000R0271	104
PM590-MC-KIT	1SAP150000R0379	104
PM590-MC-KIT	1SAP150000R0379	245
PM591-2ETH	1SAP150100R0277	104
PM591-ETH	1SAP150100R0271	104
PM591-ETH-XC	1SAP350100R0271	154
PM592-ETH	1SAP150200R0271	104
PM592-ETH-XC	1SAP350200R0271	154
PM595-4ETH-F	1SAP155500R0279	245
PM595-4ETH-F	1SAP155500R0279	105
PM595-4ETH-M-XC	1SAP351500R0279	154
PS552-MC-E	1SAP192100R0102	61
PS5601-HA-MTCP	1SAP195400R0101	61
PS5601-HA-MTCP	1SAP195400R0101	108
PS5601-HA-MTCP	1SAP195400R0101	157
PS5602-61850	1SAP195600R0101	61
PS5602-61850	1SAP195600R0101	108
PS5602-61850	1SAP195600R0101	157
PS5604-KNX	1SAP195800R0101	61
PS5604-KNX	1SAP195800R0101	108
PS5604-KNX	1SAP195800R0101	157
PS5607-BACnet-BC	1SAP195550R0101	61
PS5607-BACnet-BC	1SAP195550R0101	108
PS5607-BACnet-BC	1SAP195550R0101	157
PS5611-MC	1SAP192150R0101	61
PS5611-MC	1SAP192150R0101	108
PS5611-MC	1SAP192150R0101	157
PS5613-EIP-A	1SAP196100R0101	61
PS5613-EIP-A	1SAP196100R0101	108
PS5613-EIP-A	1SAP196100R0101	157
PS5613-EIP-A-e	1SAP196102R0101	61
PS5613-EIP-S	1SAP196101R0101	61
PS5613-EIP-S	1SAP196101R0101	108
PS5613-EIP-S	1SAP196101R0101	157
PS5613-EIP-S-e	1SAP196103R0101	61
PS562-SOLAR	1SAP195000R0101	61
PS563-WATER	1SAS030000R0101	61

Type	Order code	Page
PS564-TEMPCTRL	1SAS030010R0101	61
PS565-BACnet-ASC	1SAP195500R0101	61
SM560-S	1SAP280000R0001	200
SM560-S-FD-1	1SAP286000R0001	200
SM560-S-FD-1-XC	1SAP386000R0001	201
SM560-S-FD-4	1SAP286100R0001	200
SM560-S-FD-4-XC	1SAP386100R0001	201
SM560-S-XC	1SAP380000R0001	201
TA5101-4DI	1SAP187000R0001	78
TA5105-4DOT	1SAP187000R0002	78
TA5110-2DI2DOT	1SAP187000R0003	78
TA5120-2AI-UI	1SAP187100R0001	78
TA5122-2AI-TC	1SAP187100R0004	78
TA5123-2AI-RTD	1SAP187100R0002	78
TA5126-2AO-UI	1SAP187100R0003	78
TA5130-KNXPB	1SAP187200R0001	79
TA5131-RTC	1SAP187200R0002	77
TA5131-RTC	1SAP187200R0002	79
TA5141-RS232I	1SAP187300R0001	79
TA5142-RS485	1SAP187300R0003	79
TA5142-RS485I	1SAP187300R0002	79
TA514-SAFETY	1SAP182900R0001	200
TA514-SAFETY	1SAP182900R0001	258
TA515-CASE	1SAP182400R0002	117
TA515-CASE	1SAP182400R0002	258
TA521	1SAP180300R0001	117
TA521	1SAP180300R0001	165
TA5211-TSCL-B	1SAP187400R0001	77
TA5211-TSPF-B	1SAP187400R0002	77
TA5212-TSCL	1SAP187400R0004	77
TA5212-TSPF	1SAP187400R0005	77
TA5220-SPF5	1SAP187400R0012	79
TA5220-SPF6	1SAP187400R0013	79
TA5220-SPF7	1SAP187400R0014	79
TA5220-SPF8	1SAP187400R0015	79
TA5220-SPF9	1SAP187400R0016	79
TA523	1SAP180500R0001	117
TA523	1SAP180500R0001	165
TA524	1SAP180600R0001	117
TA524	1SAP180600R0001	165
TA525	1SAP180700R0001	117
TA525	1SAP180700R0001	165
TA526	1SAP180800R0001	117
TA526	1SAP180800R0001	165
TA527	1SAP181100R0001	117
TA527	1SAP181100R0001	165
TA528	1SAP181200R0001	117
TA528	1SAP181200R0001	165
TA5300-CVR	1SAP187500R0001	77
TA5301-CFA	1SAP187500R0003	77
TA532	1SAP182000R0001	117
TA532	1SAP182000R0001	165
TA533	1SAP182100R0001	117
TA533	1SAP182100R0001	165
TA533	1SAP182100R0001	165
TA534	1SAP182200R0001	117
TA534	1SAP182200R0001	165
TA535	1SAP182300R0001	165

Type	Order code	Page
TA536	1SAP183100R0001	117
TA536	1SAP183100R0001	165
TA540	1SAP182600R0001	117
TA540	1SAP182600R0001	165
TA5400-SIM	1SAP187600R0001	77
TA541	1SAP182700R0001	117
TA541	1SAP182700R0001	165
TA5415-STAKIT	1SAP187600R0002	259
TA5426-STAKIT	1SAP187600R0003	259
TA543	1SAP182800R0001	77
TA543	1SAP182800R0001	117
TA543	1SAP182800R0001	165
TA5450-CASE	1SAP187700R0001	117
TA5450-CASE	1SAP187700R0001	258
TA561-RTC	1SAP181400R0001	75
TA562-RS	1TNE968901R4300	75
TA562-RS-RTC	1SAP181500R0001	75
TA563-11	1TNE968901R3102	81
TA563-9	1TNE968901R3101	81
TA564-11	1TNE968901R3104	81
TA564-9	1TNE968901R3103	81
TA565-11	1TNE968901R3106	81
TA565-9	1TNE968901R3105	81
TA566	1TNE968901R3107	75
TA569-RS-ISO	1SAP186400R0001	75
TA570	1TNE968901R3203	75
TA571-SIM	1TNE968903R0203	75
TA574-D-T-ETH	1SAP186200R0004	259
TB511-ARCNET	1SAP111100R0260	106
TB511-ETH	1SAP111100R0270	106
TB511-ETH-XC	1SAP311100R0270	155
TB521-ARCNET	1SAP112100R0260	106
TB521-ETH	1SAP112100R0270	106
TB521-ETH-XC	1SAP312100R0270	155
TB523-2ETH	1SAP112300R0277	106
TB541-ETH	1SAP114100R0270	106
TB541-ETH-XC	1SAP314100R0270	155
TB5600-2ETH	1SAP110300R0278	109
TB5600-2ETH-XC	1SAP310300R0278	158
TB5610-2ETH	1SAP111300R0278	109
TB5610-2ETH-XC	1SAP311300R0278	158
TB5620-2ETH	1SAP112300R0278	109
TB5620-2ETH-XC	1SAP312300R0278	158
TB5640-2ETH	1SAP114300R0278	109
TB5640-2ETH-XC	1SAP314300R0278	158
TB5660-2ETH	1SAP116300R0278	109
TB5660-2ETH-XC	1SAP316300R0278	158
TF501-CMS	1SAP117000R0271	107
TF501-CMS-XC	1SAP317000R0271	156
TF521-CMS	1SAP117200R0271	107
TF521-CMS-XC	1SAP317200R0271	156
TK503	1TNE968901R1100	75
TK504	1TNE968901R2100	75
TK506	1SAP186100R0001	75
TK681	1SAP500981R0001	216
TK682	1SAP500982R0001	216
TU507-ETH	1SAP214200R0001	115

## Index

### Type classification

Type	Order code	Page
TU508-ETH	1SAP214000R0001	115
TU508-ETH-XC	1SAP414000R0001	163
TU509	1SAP211000R0001	115
TU510	1SAP210800R0001	115
TU510-XC	1SAP410800R0001	163
TU515	1SAP212200R0001	115
TU516	1SAP212000R0001	115
TU516-H	1SAP215000R0001	114
TU516-H-XC	1SAP415000R0001	163
TU516-XC	1SAP412000R0001	163
TU517	1SAP211400R0001	115
TU518	1SAP211200R0001	115
TU518-XC	1SAP411200R0001	163
TU520-ETH	1SAP214400R0001	115
TU520-ETH-XC	1SAP414400R0001	163
TU531	1SAP217200R0001	115
TU532	1SAP217000R0001	115
TU532-H	1SAP215100R0001	114
TU532-H-XC	1SAP415100R0001	163
TU532-XC	1SAP417000R0001	163
TU541	1SAP213000R0001	115
TU542	1SAP213200R0001	115
TU542-H	1SAP215200R0001	114
TU542-H-XC	1SAP415200R0001	163
TU542-XC	1SAP413200R0001	163
TU551-CS31	1SAP210600R0001	115
TU552-CS31	1SAP210400R0001	115
TU552-CS31-XC	1SAP410400R0001	163
TU582-S	1SAP281200R0001	200
TU582-S-XC	1SAP481200R0001	201



**Additional information**

We reserve the right to make technical changes or modify the contents of this document without prior notice. ABB does not accept any responsibility whatsoever for potential errors or possible lack of information in this document.

We reserve all rights in this document and in the subject matter and illustrations contained therein. Any reproduction, disclosure to third parties or utilization of its contents – in whole or in parts – is forbidden without prior written consent of ABB.





—

**ABB AG**

Eppelheimer Straße 82  
D-69123 Heidelberg / Germany  
Tel.: +49 62 21 701 1444  
Fax: +49 62 21 701 1382



[www.abb.com/plc](http://www.abb.com/plc)



[www.abb.com/automationbuilder](http://www.abb.com/automationbuilder)